

UGEAR'S®

Set of Additions to the model «Truck UGM-11.»  
Набір доповнень до моделі "Вантажівка UGM-11".

DEU Erweiterungs-Set für Modell „Lastkraftwagen UGM-11“. FRA Ensemble d'éléments complémentaires pour le camion UGM-11.  
POL Zestaw dodatków kompatybilnych z modelem Ciężarówka UGM-11. SPA Conjunto de las adiciones para el modelo del camión UGM-11.  
ITA Il completo dei supplementi per il modello "Camion UGM-11". TUR Model "Kamyon UGM-11" için ek parçalar takımı.  
RUS Набор дополнений к модели "Грузовик UGM-11". KOR 트럭 UGM-11 부가 상품 CHI "UGM-11卡车周边套" 模型

Assembly instructions  
Інструкція зі складання

DEU Aufbauanleitung. FRA Notice d'assemblage. POL Instrukcja montażu.  
SPA Instrucciones de montaje. ITA Istruzioni di montaggio. TUR Kurulum talimatı. RUS Инструкция по сборке. KOR 조립 설명서.  
CHI 装配说明书



p. 4



p. 36



p. 66

**UKR**

Інструкція зі складання:  
Витягніть з дошки позначені на схемі деталі. Намагайтеся їх не зламати. Якщо деталь не виймається, надсічіть перемички ножом. Конструкція збирається без клею. У разі виникнення труднощів з протягуванням зубочистки (вісі) в отвір потріть зубочистку об звичайну свічку. Також можна змастити свічкою всі деталі механізму, що рухаються, щоб зменшити тертя при обертанні.

**TUR**

Kurulum talimatı:  
Şemada işaretlenen parçaları tahtadan çıkarın. Kırılmamasına dikkat ediniz. Parça çıkarılmıyorsa bağlantı yerleri bıçakla kesiniz. Konstruksyon, yapıştırıcı kullanmadan yapılmaktadır. Tahta dingilini (kürdan) deliğin içine yerleştirmede zorluk çekiyorsanız önceden dingile veya parçalara mum sürünüz. Hareketli parçaların daha iyi kayması için kurulum sırasında parçalara mum sürünüz.

**ENG**

Assembly Instructions:  
Remove model parts from the hanger board as illustrated below. Careful not to break parts. If a part does not remove easily, carefully cut it out with a knife. This model is intended for self-assembly without glue. If you have difficulty installing the axles, try waxing them with a regular candle. All moving parts can also be waxed during assembly to reduce friction when operating the model.

**RUS**

Инструкция по сборке:  
Вынимайте из доски обозначенные на схеме детали. Старайтесь их не сломать. Если деталь не извлекается, надрежьте перемычки ножом. Конструкция собирается без клея. Если возникли трудности с установкой деревянной оси, перед установкой потрите детали об обычную свечу. Для лучшего скольжения смазывайте движущиеся детали механизма обычной свечой во время сборки.

**DEU**

Aufbauanleitung:  
Bitte die in der Zeichnung angegebenen Teile aus der Platte herausnehmen. Versuchen Sie bitte diese nicht zu brechen. Wenn sich ein Teil nicht herausnehmen lässt, schneiden Sie die Stege mit dem Messer leicht an. Das Modell wird ohne Klebstoffe zusammgebaut. Lässt sich eine Achse nur schwer in eine Öffnung einführen, reiben Sie diese mit einer Kerze etwas ein. Für besseres Gleiten schmieren Sie alle beweglichen Teile mit einer Kerze.

**KOR**

조립 설명:  
부품이 손상되지 않도록 주의하여 보드에서 떼어냅니다. 만약 부품이 잘 떨어지지 않으면 연결 부분을 칼로 절단 한 후 떼어내면 쉽게 떼어 낼 수 있습니다. 본 제품은 접착제가 없이 조립이 가능하도록 설계되어 있습니다. 만약 축이 잘 끼워지지 않는 경우 양초를 축에 바른 후 끼워보세요. 모든 구동 부위는 제품 구동 시 원활한 작동이 가능하도록 조립 과정에서 윤활제(양초)양초를 발라 주세요.

**FRA**

Notice d'assemblage:  
Faites sortir de la planche les pièces comme indiquées sur le schéma. Tâchez de ne pas les casser. Si la pièce ne sort pas, incisez les collages/fixations avec un couteau. La construction est à assembler sans colle. Si il est difficile d'introduire l'axe en bois dans l'orifice, frottez au préalable l'axe ou les pièces contre une bougie. Pour améliorer le glissement, traitez les pièces de frottement mobiles du mécanisme avec une bougie au cours d'assemblage.

**CHI**

装配说明  
将模型部件按插图所示，从胶合板取下。小心不要损坏件。如果取下时候有难度，请用小刀小心的切割连接点。这个产品不需要胶水粘接。如果安装转轴的时候有难度，请用普通的蜡加以润滑。所有的转动部分也需要打蜡润滑。

**POL**

Instrukcja montażu:  
Delikatnie wyciągaj z deseczki wskazane w schemacie detale, starając się nie potać elementów. Jeśli detal nie poddaje się, podetnij wiązadła nożem. Konstrukcję składa się bez kleju. Jeśli napotkasz trudności z instalacją drewnianej osi w otwór, potrzyj na początku oś lub detale o woskową świecę. Dla lepszego poślizgu polecano smarowanie ruchomych części mechanizmu zwykłą świecą podczas montażu.

**SPA**

Instrucciones de montaje:  
Saque de la tabla las piezas marcadas en el esquema. Trate de no romperlas. Si una pieza no se saca, haga una incisión. La construcción va sin pegamento. Si tiene dificultades con la instalación del eje de madera en un agujero, frote primero el eje o las piezas contra una vela. Para un mejor deslizamiento, lubrique durante el montaje las piezas móviles del mecanismo con una vela común.

**ITA**

Istruzioni di montaggio:  
Estrarre dal telaio i particolari indicati nello schema. Fare attenzione a non romperli. Se un particolare non si stacca, tagliare delicatamente gli elementi di collegamento con un coltello. L'assieme viene realizzato senza colla. In caso di difficoltà nell'inserimento di un perno in legno, è necessario sfregare il perno o il particolare con un po' di cera. Per uno scorrimento migliore incerase le parti mobili del meccanismo durante l'assemblaggio.

**UKR** Увага! **ENG** Warning! **DEU** Achtung! **FRA** Attention! **POL** Uwaga! **SPA** Precaución!  
**ITA** Attenzione! **TUR** Dikkat! **RUS** Внимание! **KOR** 주의! **CHI** 注意!



**UKR** Не підпалювати! **ENG** Do not use a lighted candle! **DEU** Nicht anzünden! **FRA** Ne pas brûler! **POL** Nie podpalać! **SPA** ¡No encender!  
**ITA** Non dare fuoco! **TUR** Yakmayınız! **RUS** Не поджигать! **KOR** 불이 붙은 초를 이용하지 마세요! **CHI** 请勿点燃，请勿靠近火源!



**UKR** Обережно! Гострі деталі! **ENG** Caution! Axles have sharp points!  
**DEU** Vorsicht! Spitze Teile! **FRA** Attention: certaines pièces sont pointues!  
**POL** Ostrożnie! Ostre części! **SPA** ¡Atención! Piezas afiladas!  
**ITA** Attenzione! Particolari appuntiti! **TUR** Dikkat! Keskin parçalar!  
**RUS** Осторожно! Острые детали! **KOR** 축의 뾰족한 부분에 주의하세요!  
**CHI** 注意! 舍尖锐物件

**ENG** Symbols. **UKR** Умовні позначення. **DEU** Legende. **FRA** Légende. **POL** Oznaczenia umowne. **SPA** Leyenda. **ITA** Legenda. **TUR** Kararlaştırılan işaretler. **RUS** Условные обозначения. **KOR** 기호. **CHI** 图标含义



**ENG** Wax the part with a regular candle (rub with a candle). **UKR** Змастіть деталь звичайною свічкою (потріть об свічку). **DEU** Reiben Sie das Teil mit einer einfachen Kerze etwas ein. **FRA** Lubrifiez la pièce avec une bougie ordinaire (frottez contre la bougie). **POL** Przesmaruj zwykłą świecą. **SPA** Engrase la pieza con una vela común (frote con una vela). **ITA** Incerare il componente (Sfregare con la cera). **TUR** Parçaya sade mum sürünüz. **RUS** Смажьте деталь обычной свечкой (потрите о свечку). **KOR** 표시된 부분에 윤활을 위해 초를 칠해 주세요. **CHI** 用普通蜡烛涂抹润滑部件



**ENG** Check size. **UKR** Перевірте розмір. **DEU** Prüfen Sie die Größe. **FRA** Vérifiez la dimension. **POL** Sprawdź rozmiar. **SPA** Compruebe el tamaño. **ITA** Controllare le dimensioni. **TUR** Boyutu kontrol ediniz. **RUS** Проверьте размер. **KOR** 크기를 확인하세요. **CHI** 测量尺寸



**ENG** Break off or cut out. **UKR** Відламайте або відріжте. **DEU** Abbrechen oder Abschneiden. **FRA** Coupez ou cassez. **POL** Odlam lub odetnij. **SPA** Rompa o corte. **ITA** Staccare o tagliare. **TUR** Kirin veya kesin. **RUS** Отломайте или отрежьте. **KOR** 잘라내 주세요. **CHI** 切断



**ENG** Pay attention. Check for correct orientation or positioning. **UKR** Зверніть увагу. Перевірте розташування елемента. **DEU** Bitte Beachten. Prüfen Sie die Einbaulage des Elementes. **FRA** Faites attention. Vérifiez la disposition de l'élément. **POL** Zwróć uwagę. Sprawdź lokalizację elementu. **SPA** Atención. Compruebe la situación del elemento. **ITA** Prestare attenzione. Controllare la posizione del componente. **TUR** Dikkat. Elemanın yerleşimini kontrol ediniz. **RUS** Обратите внимание. Проверьте расположение элемента. **KOR** 방향 또는 위치에 주의해서 조립해 주세요. **CHI** 注意！检查部件方向和位置



**ENG** Spare parts. **UKR** Запасні деталі. **DEU** Ersatzteile. **FRA** Pièces de rechange. **POL** Części zamienne. **SPA** Piezas de repuesto. **ITA** Pezzi di ricambio. **TUR** Yedek parçalar. **RUS** Запасные детали. **KOR** 여유 부품입니다. **CHI** 备用件



**ENG** Cut crosspieces before removing the part from the board. **UKR** Обріжте перемички перед витяганням деталі. **DEU** Schneiden Sie die Stege ein, bevor Sie das Teil rausnehmen. **FRA** Découpez les fixations avant de retirer les pièces. **POL** Obetnij uszczelnienia przed wyjmowaniem elementu. **SPA** Corte los puentes antes de extraer la pieza. **ITA** Tagliare gli elementi di collegamento prima di estrarre i particolari. **TUR** Parçaları çıkarmadan önce bağlantı yerlerini kesiniz. **RUS** Обрежьте перемычки перед выниманием детали. **KOR** 부품을 떼어내기 전, 연결 부분을 잘라 주세요. **CHI** 在取下部件前切断连接点



**ENG** Perform the same steps in mirror image. **UKR** Здійснити аналогічне складання у дзеркальному відображенні. **DEU** Den analogen Zusammenbau in der Spiegelreflexion zu machen. **FRA** Procédez à l'assemblage dans le sens opposé (inverse). **POL** Dokonaj analogiczny montaż w odbiciu lustrzanym. **SPA** Haga un ensamblaje similar en imagen especular. **ITA** Realizzare lo stesso assemblaggio nell'immagine speculare. **TUR** Ayna yansımada aynı montaj yapınız. **RUS** Произвести аналогичную сборку в зеркальном отражении. **KOR** 동일한 부품을 대칭이 되도록 쌍으로 작업해 주세요. **CHI** 在镜面对称执行相同的步骤



**ENG** Axle. **UKR** Біць. **DEU** Achse. **FRA** Axe. **POL** Oś. **SPA** Eje. **ITA** Perno. **TUR** Dingil. **RUS** Ось. **KOR** 축. **CHI** 轴承



**ENG** This is not a structural component; it is a tool for measurement and assembly. **UKR** Це не деталь конструкції, а допоміжний інструмент для складання або вимірювання відстаней. **DEU** Es ist kein Teil der Konstruktion, sondern ein Hilfselement für den Zusammenbau oder für das Messen der Abstände. **FRA** Cette pièce ne fait pas partie de la construction mais constitue un outil annexe pour l'assemblage ou la mesure des distances. **POL** To nie detal konstrukcji, a pomocnicze narzędzie dla montażu i wymiaru odległości. **SPA** No es una pieza de la construcción sino un instrumento auxiliar para montar o para medir distancias. **ITA** Non è un componente del modello, ma un'attrezzatura aggiuntiva per il montaggio o il rilievo delle quote. **TUR** Yapı parçası değil. Kurulum yapmak veya mesafe ölçmek amacıyla kullanılan yardımcı alettir. **RUS** Это не деталь конструкции, а вспомогательный инструмент для сборки или измерения расстояний. **KOR** 이 부품은 조립을 위한 부품이 아니고 조립을 돕거나 측정을 위한 도구입니다. **CHI** 这不是装配零部件，是一种测量及安装辅助工具。

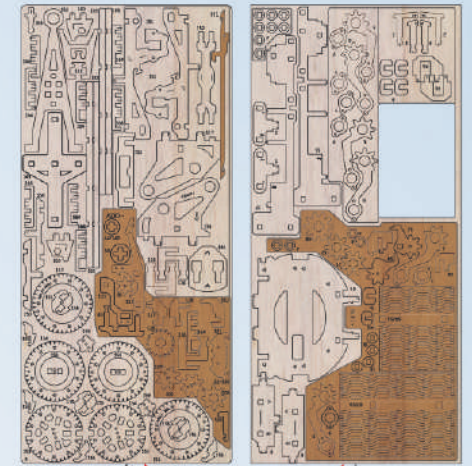

ENG Tanker. UKR Цистерна. DEU Tankwagen.  
FRA Citerne. POL Cysterne. SPA Cisterna. ITA Autocisterna.  
TUR Tanker RUS Цистерна. KOR 캔운반차. CHI 罐车

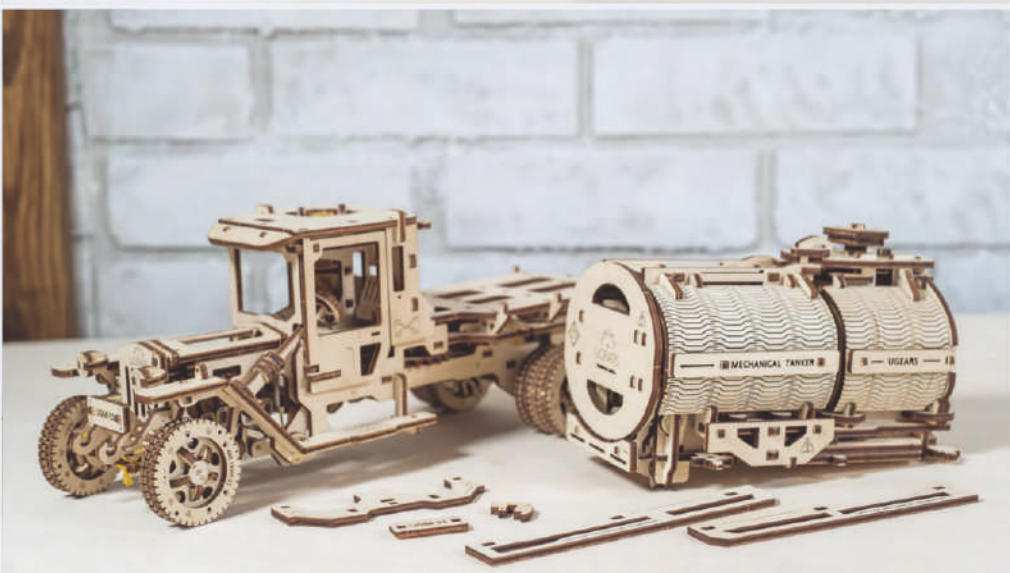
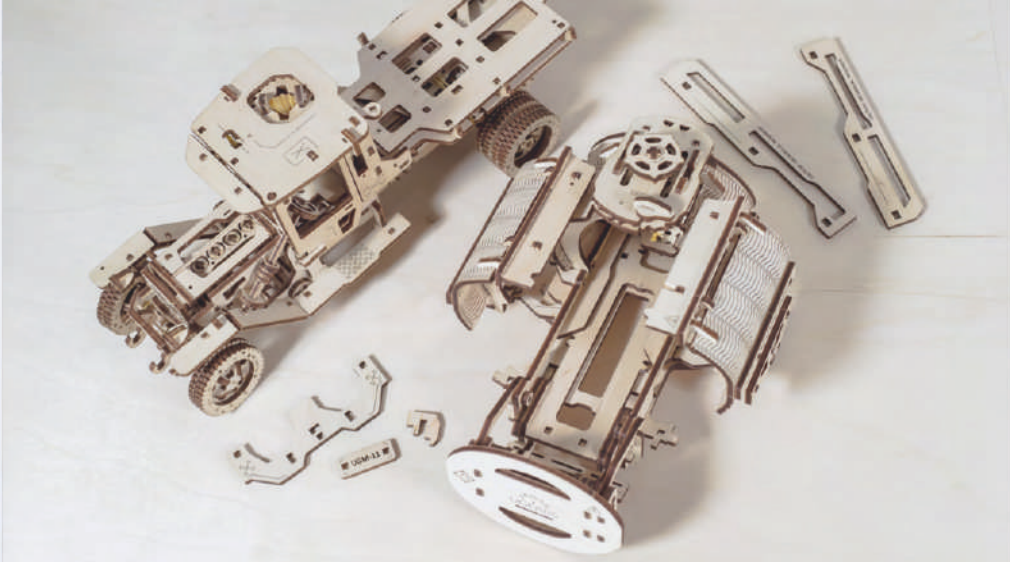
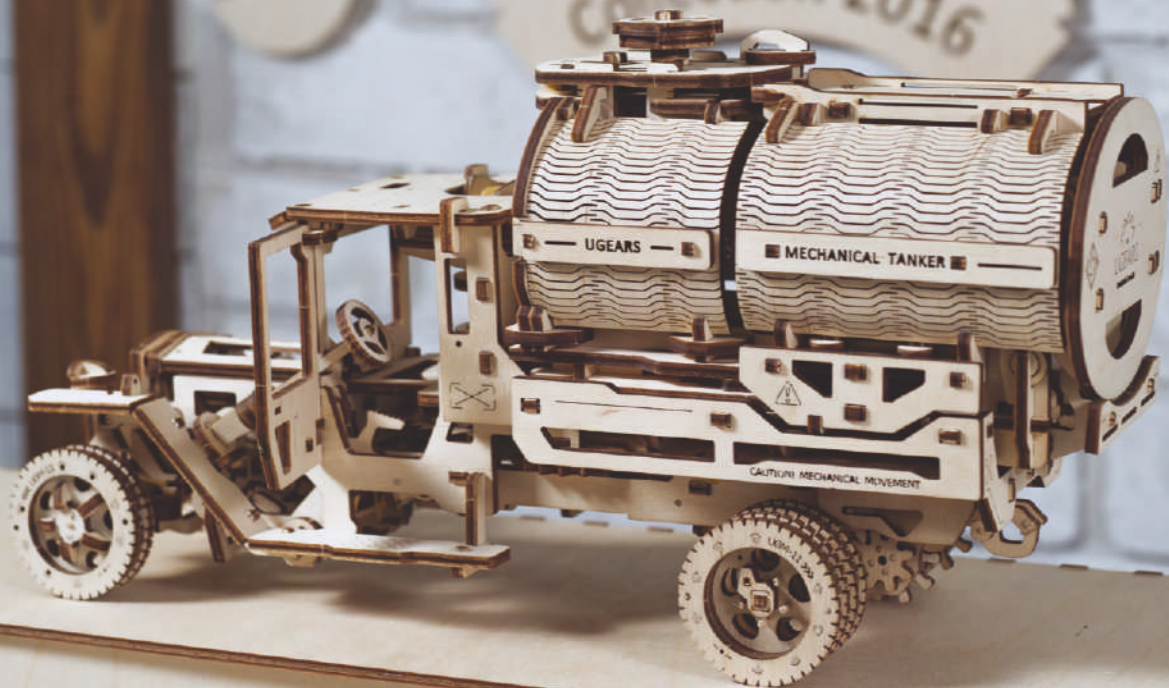

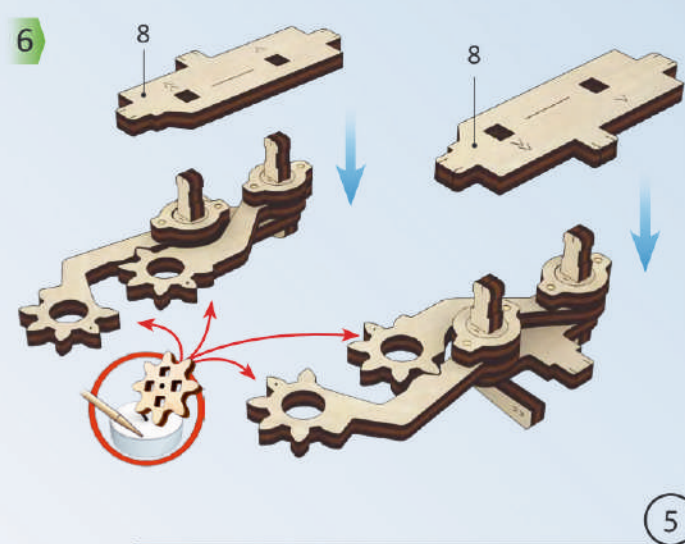
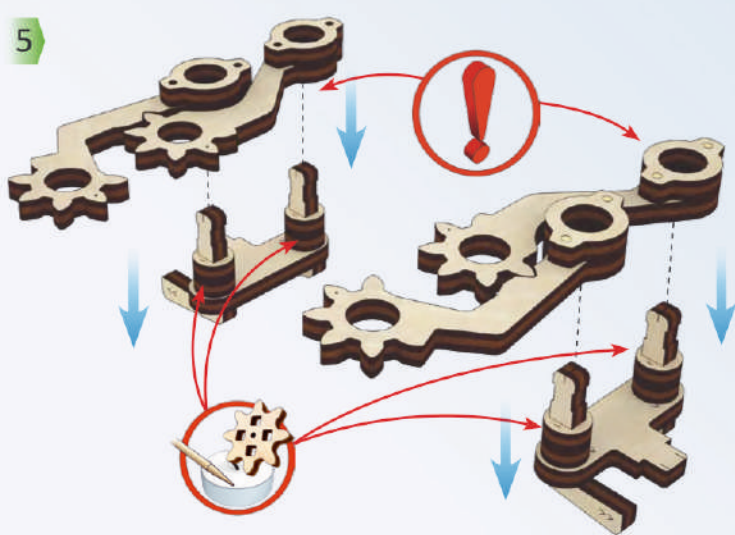
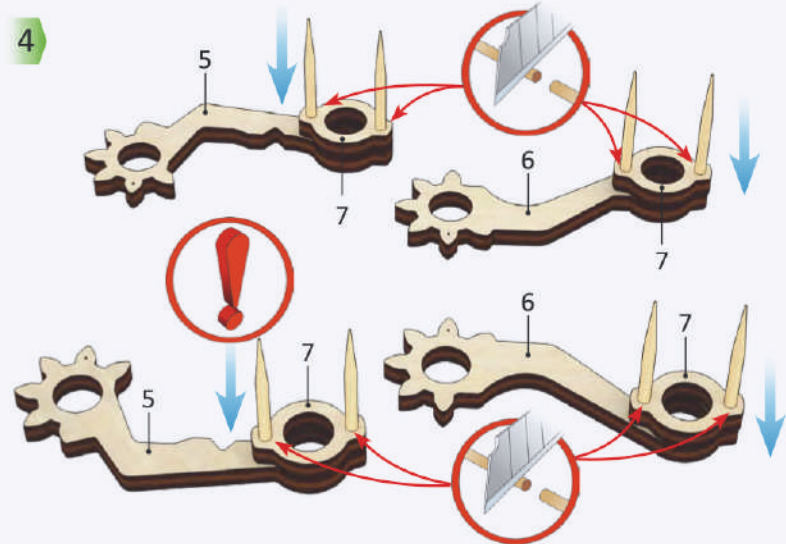
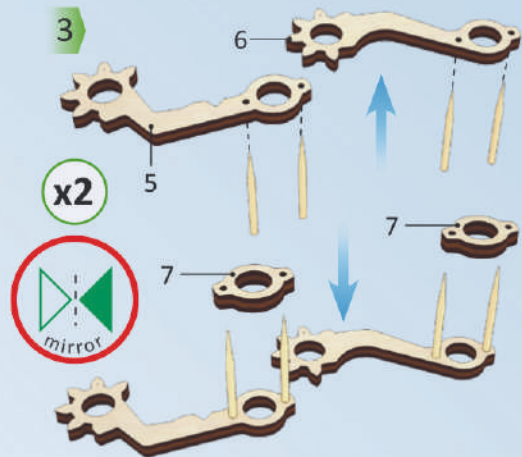
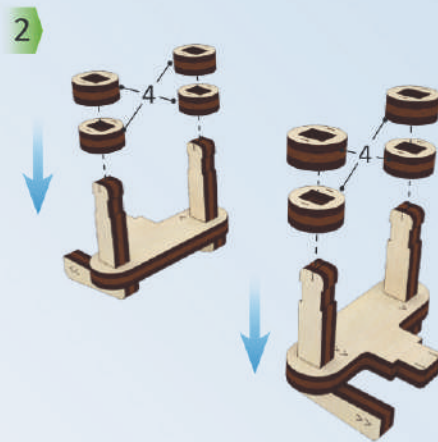
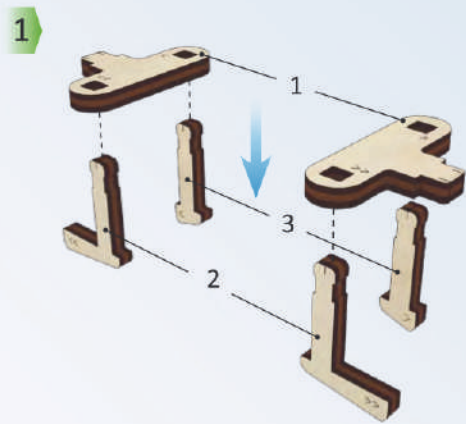
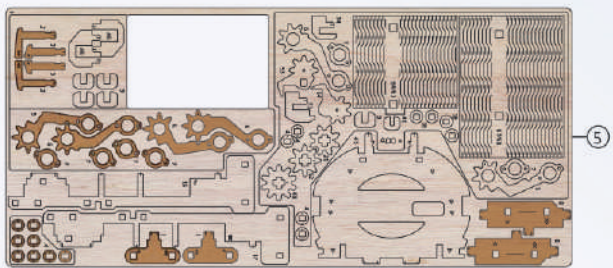

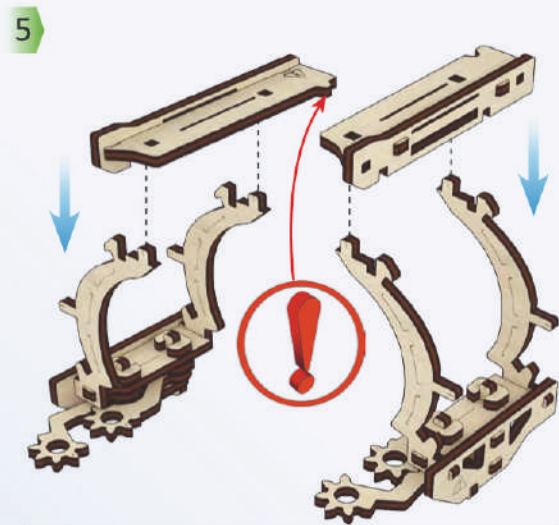
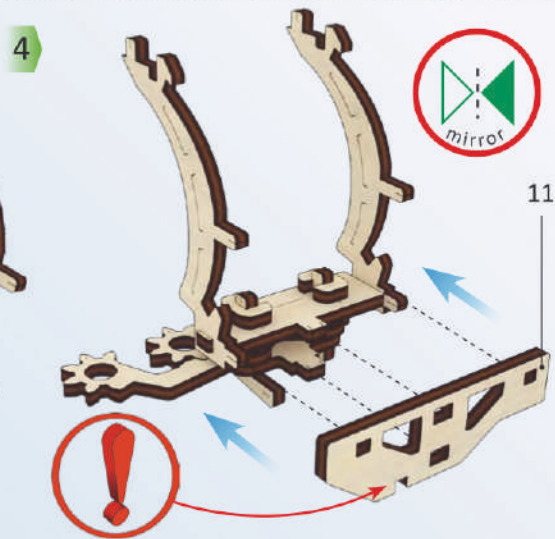
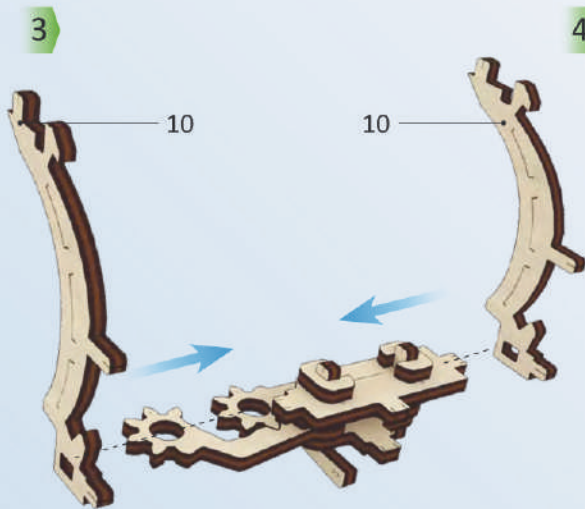
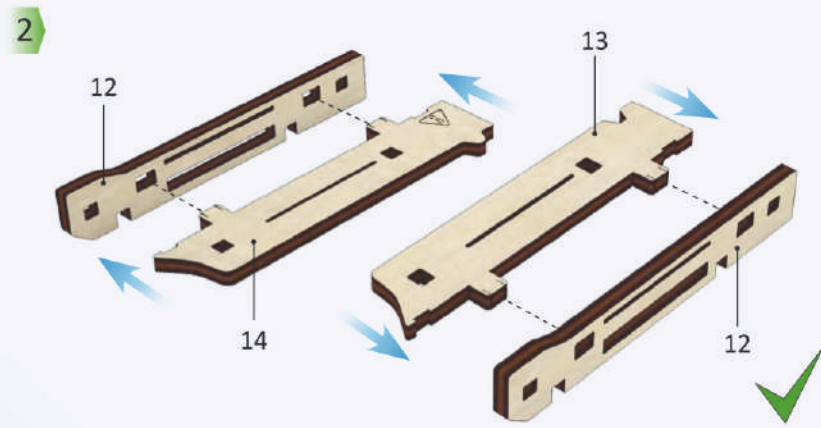
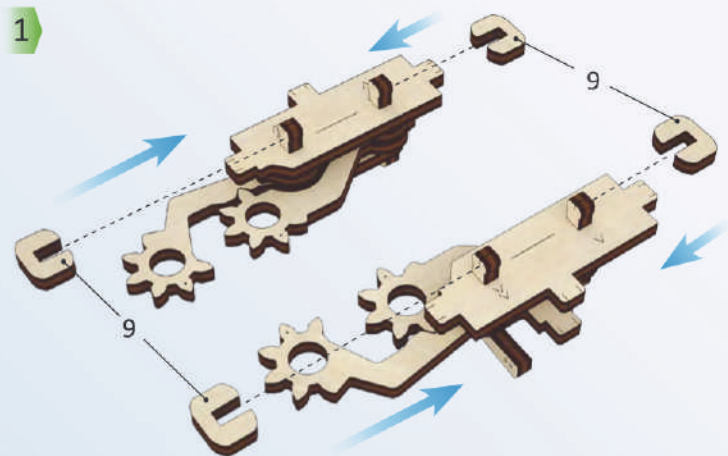
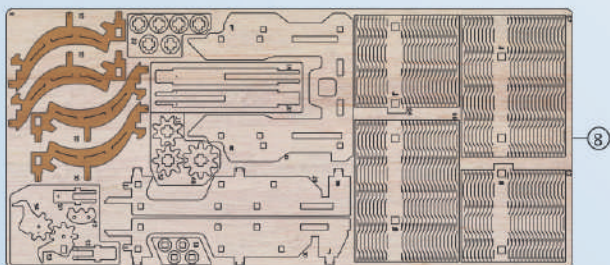
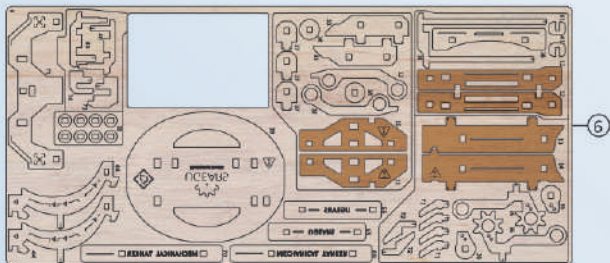
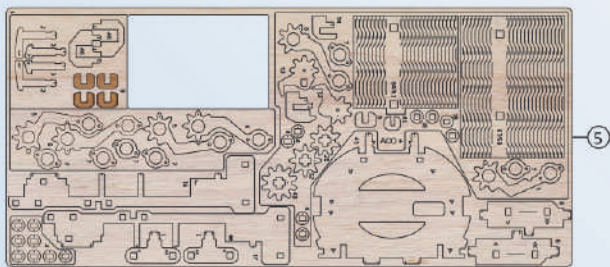

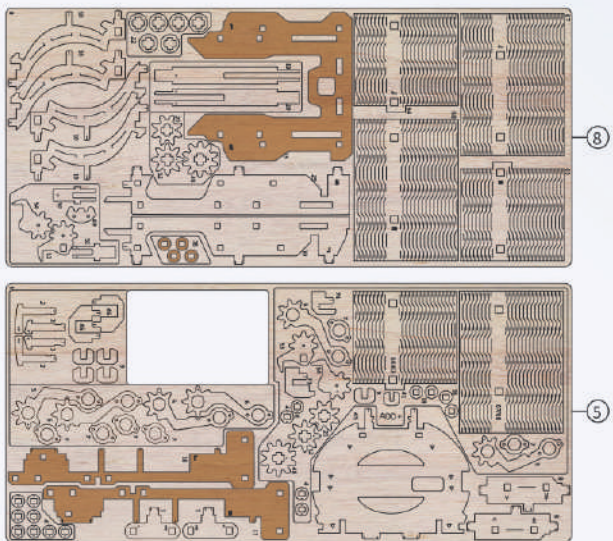

6

A-1

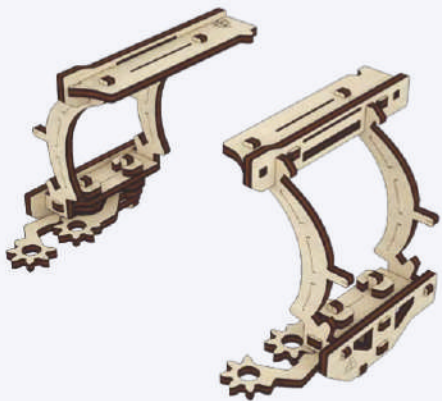

A-2

1

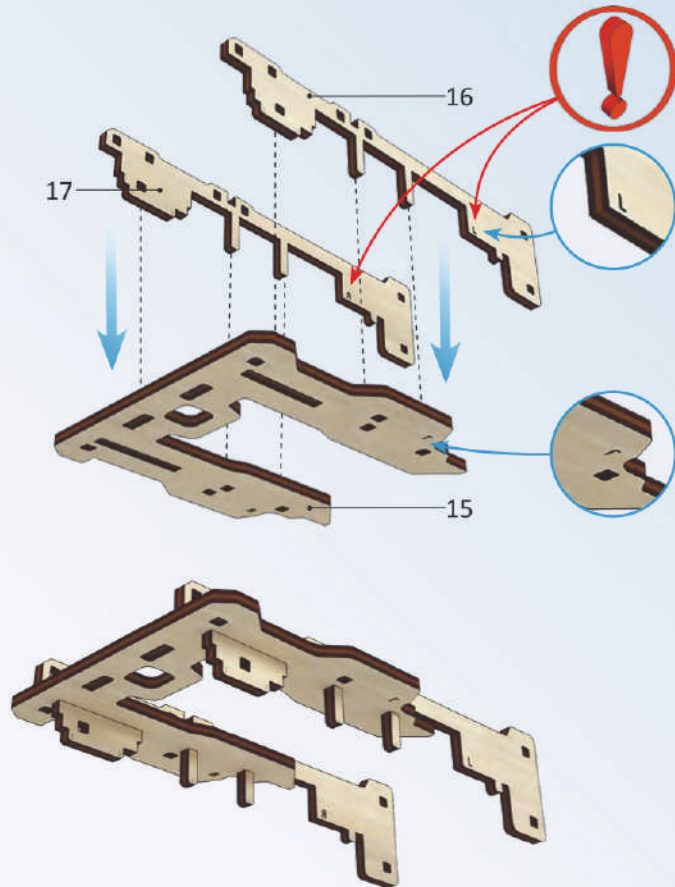

2

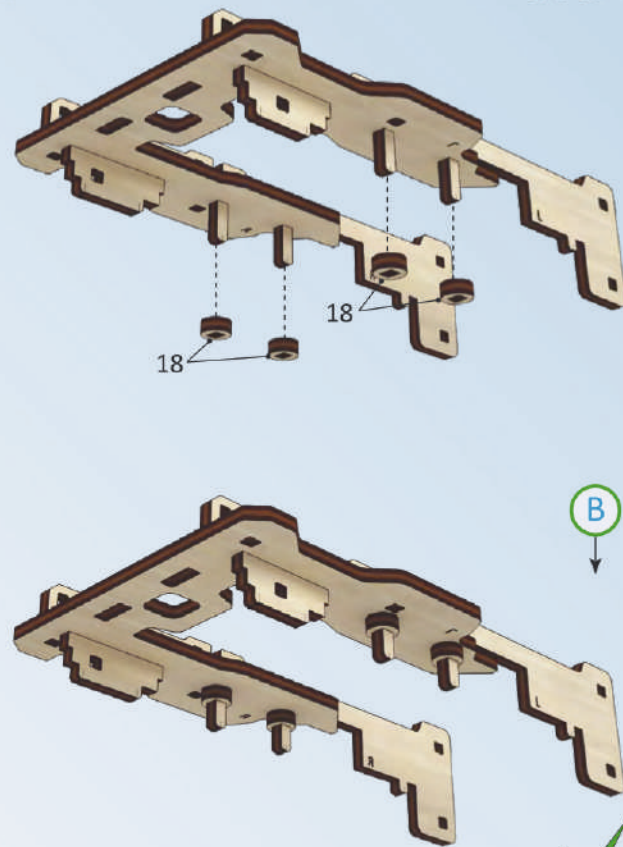

7

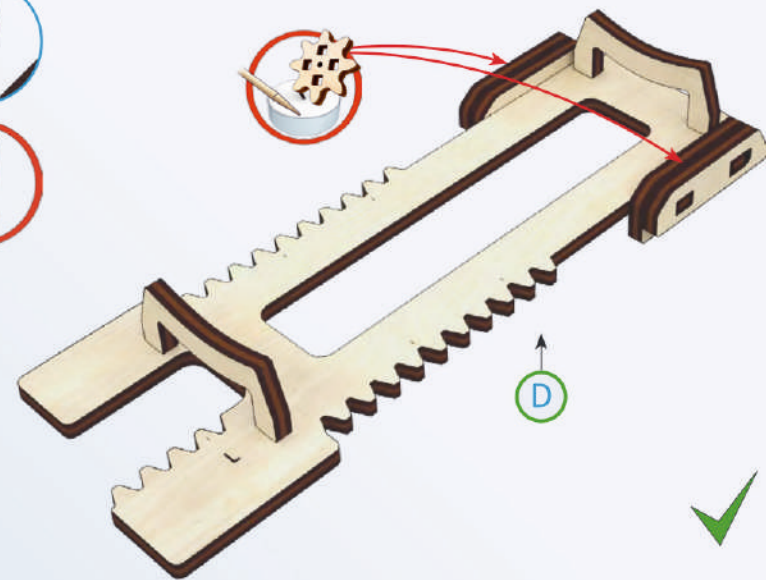
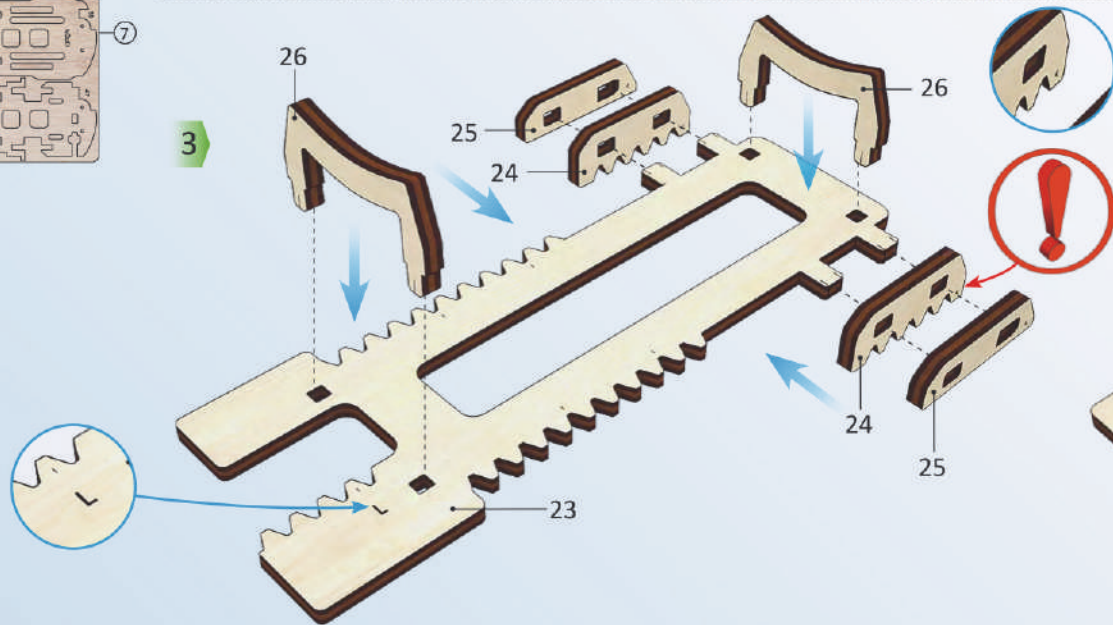
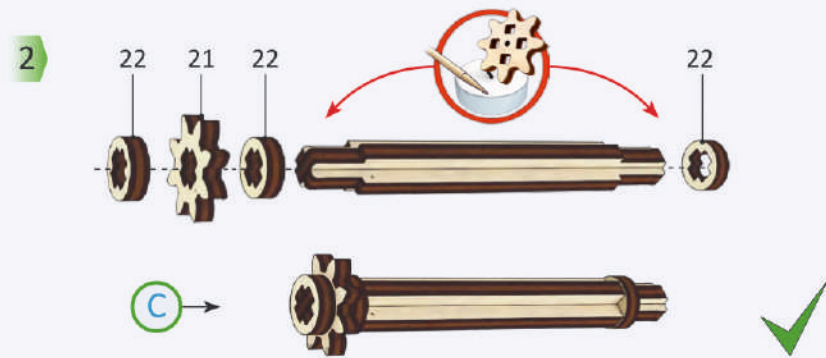
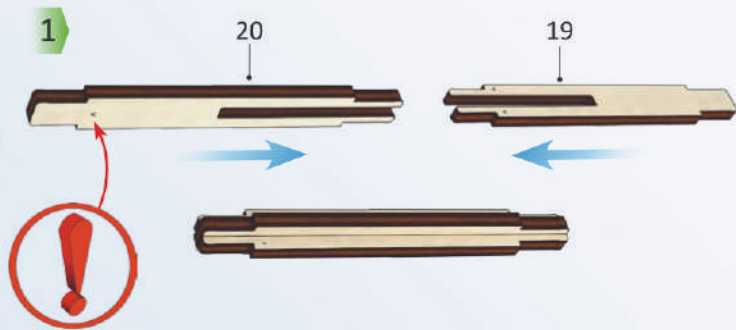
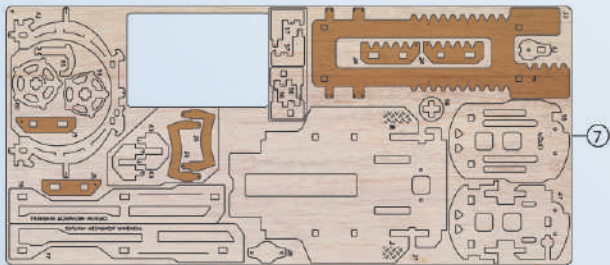
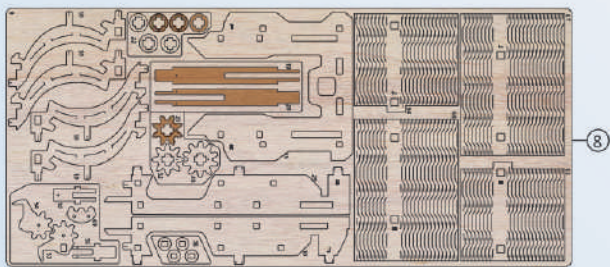



1

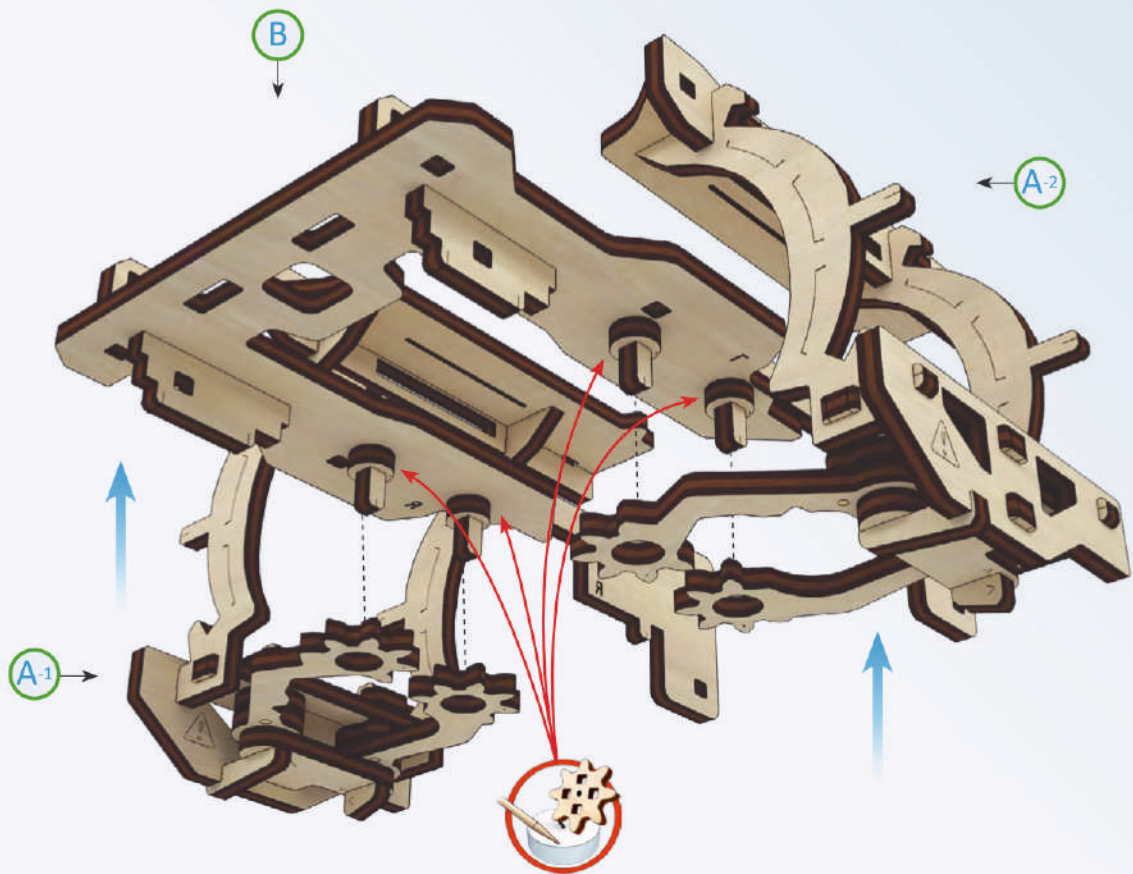

2

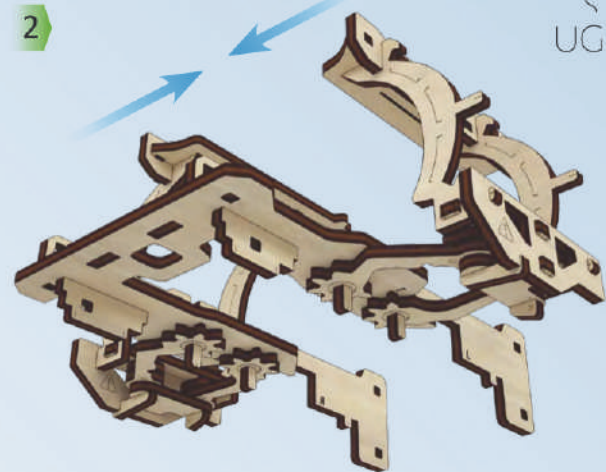

3

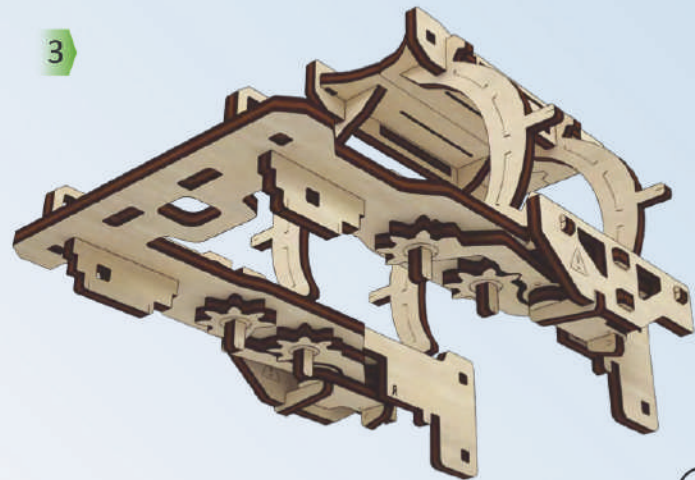

1

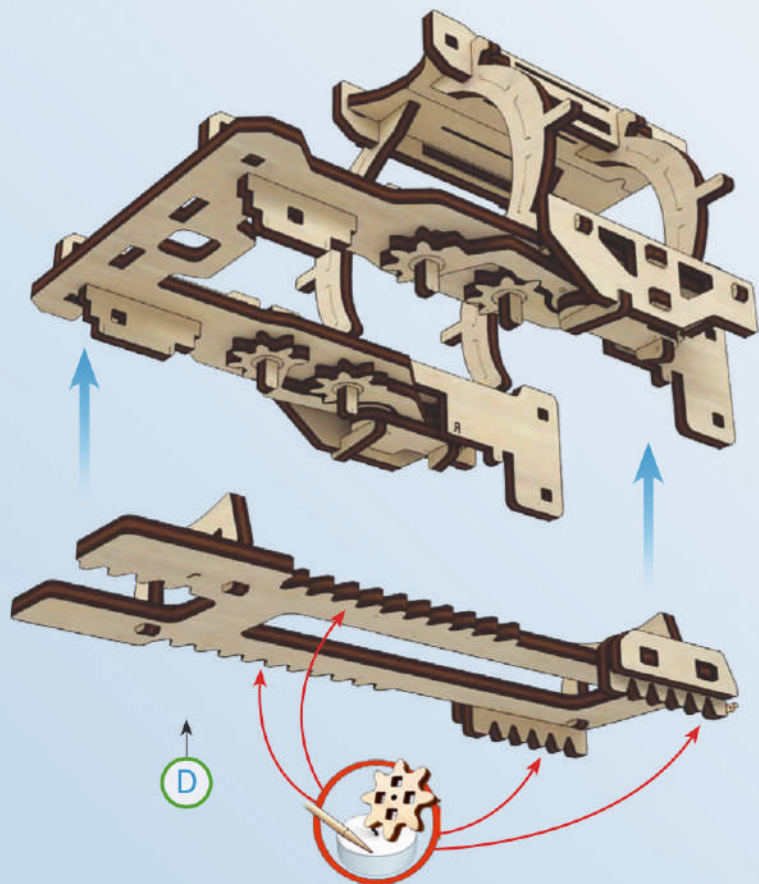

2

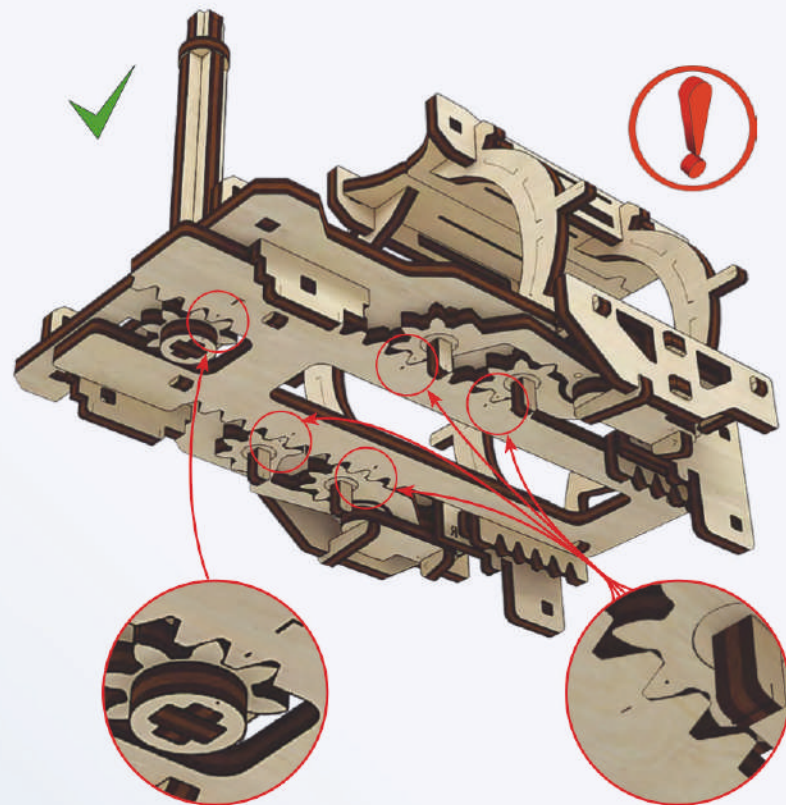
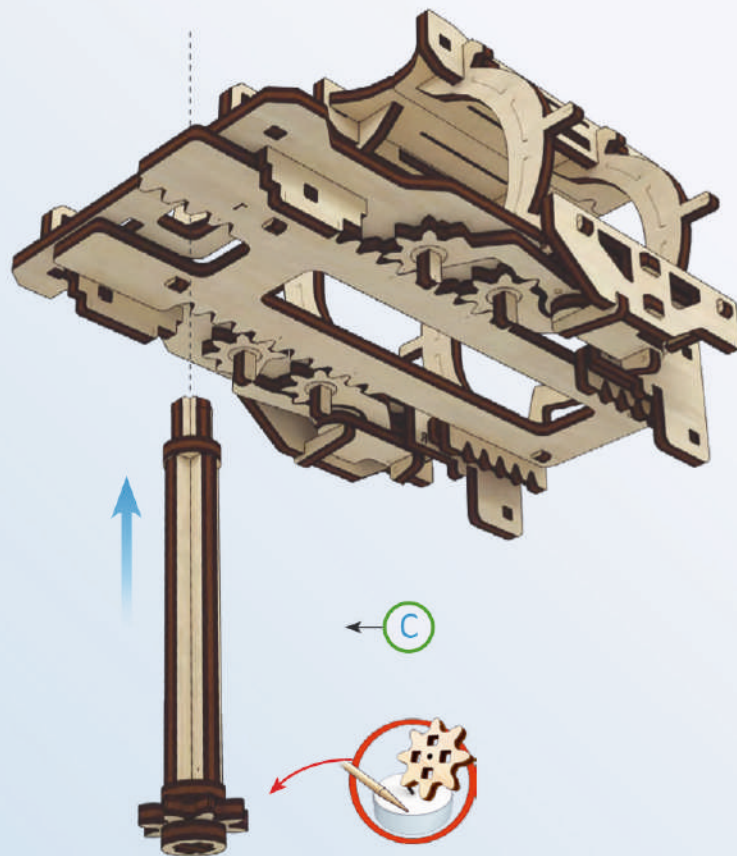

ENG Put the marks together. UKR Поєднайте мітки. DEU Führen Sie die Markierungen zusammen. FRA Alignez les marques. POL Złóżyc znaki. SPA Juntarà los las marcas. ITA Unire ed assemblare gli incastri. TUR İşaretleri birleştirin. RUS Совместите метки. KOR 표시된 부분을 맞춰 주세요. CHI 重合标志

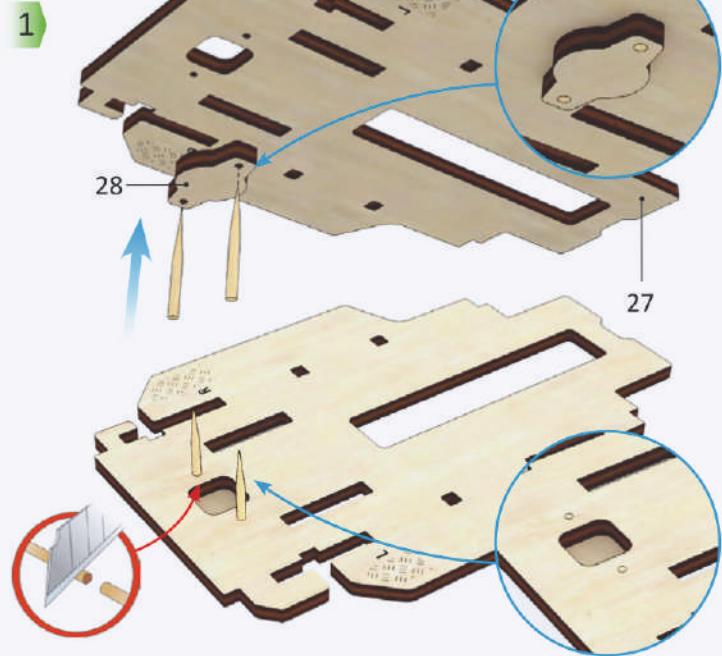
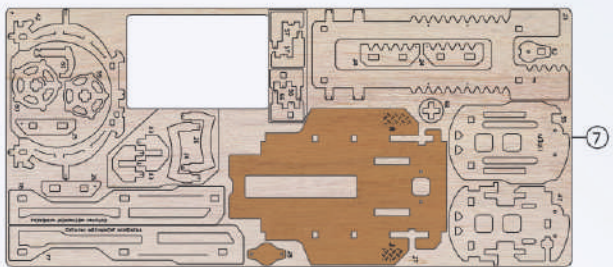

2

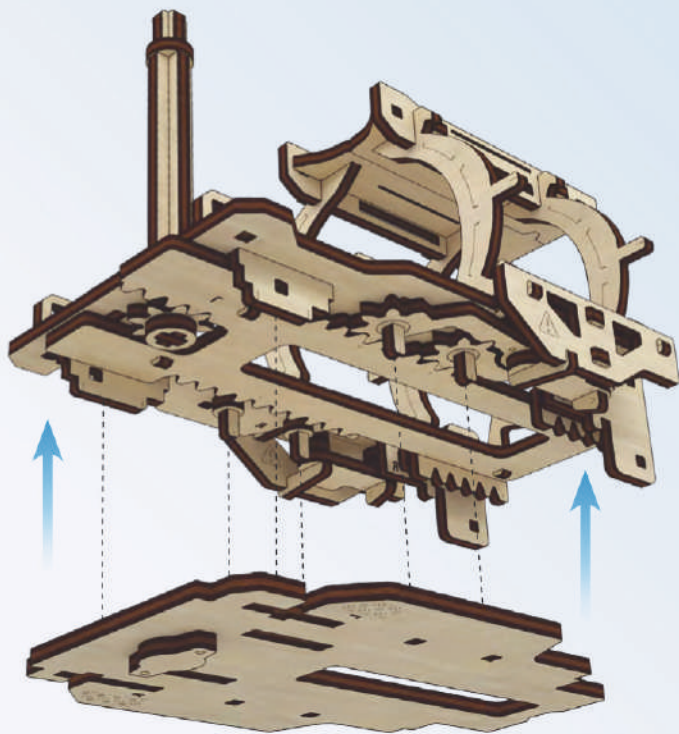

3

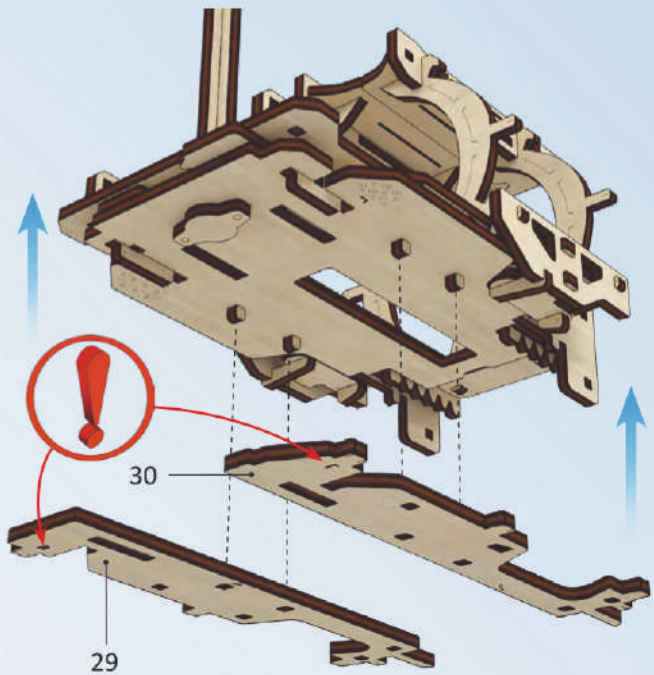
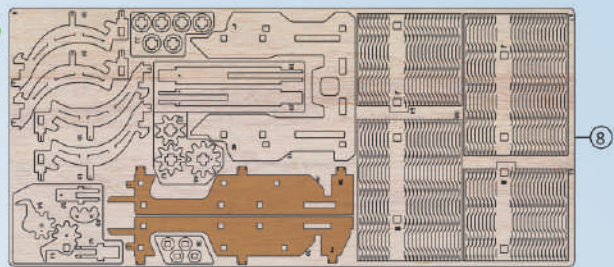

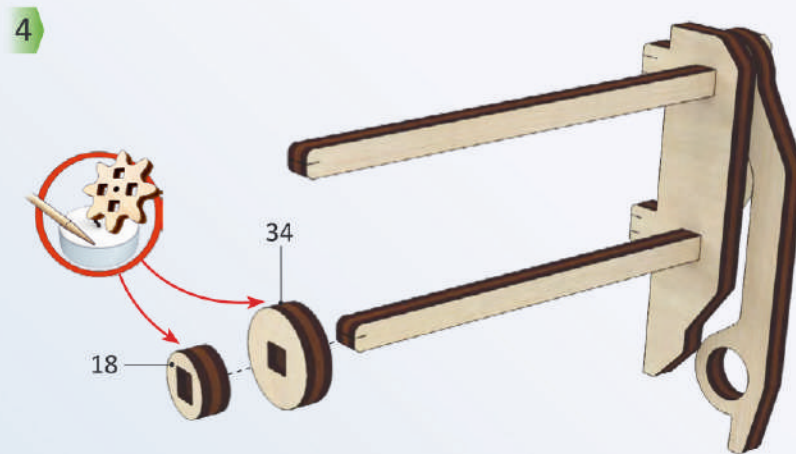
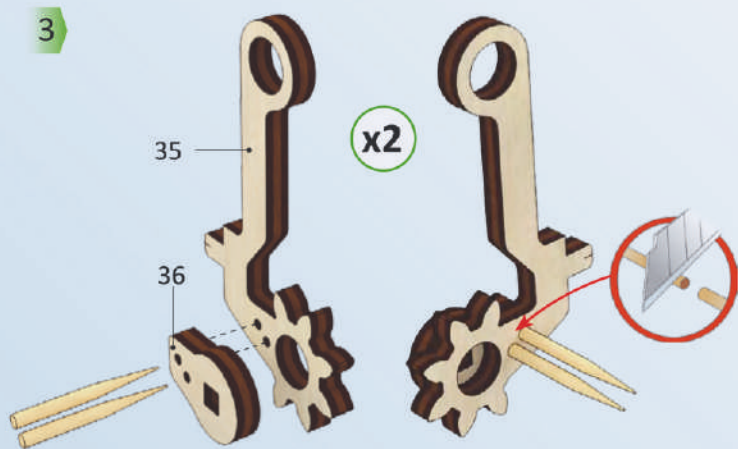
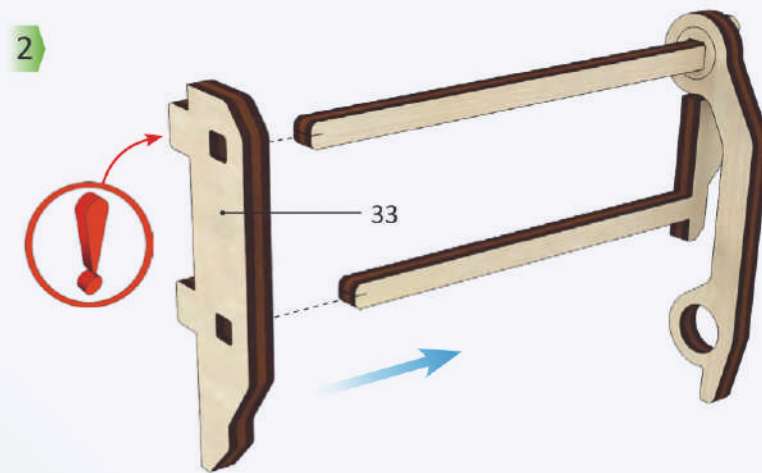
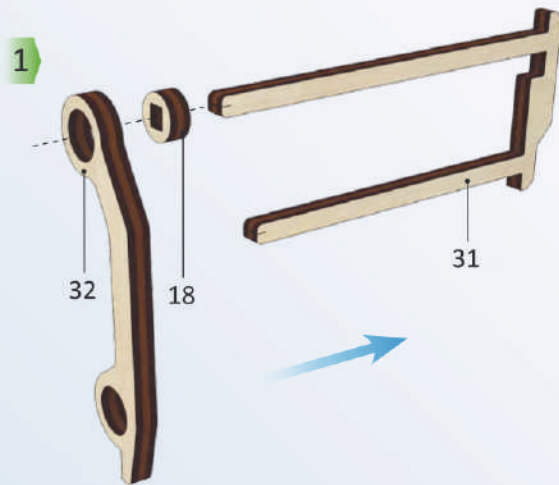
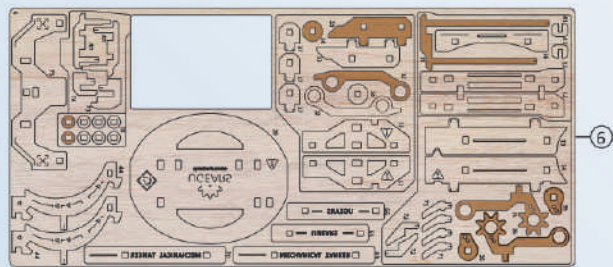

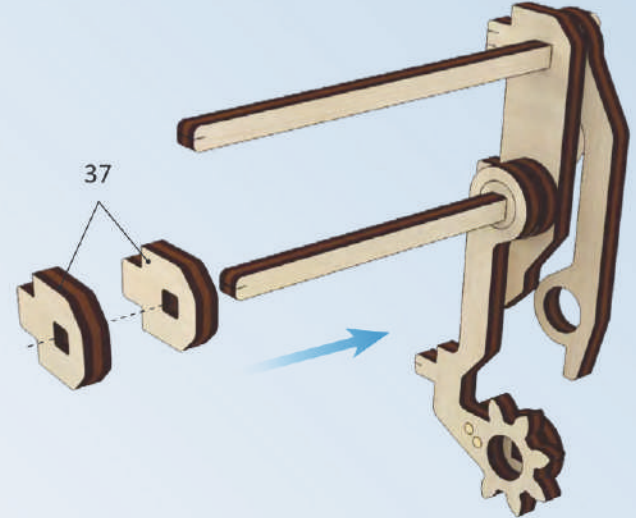
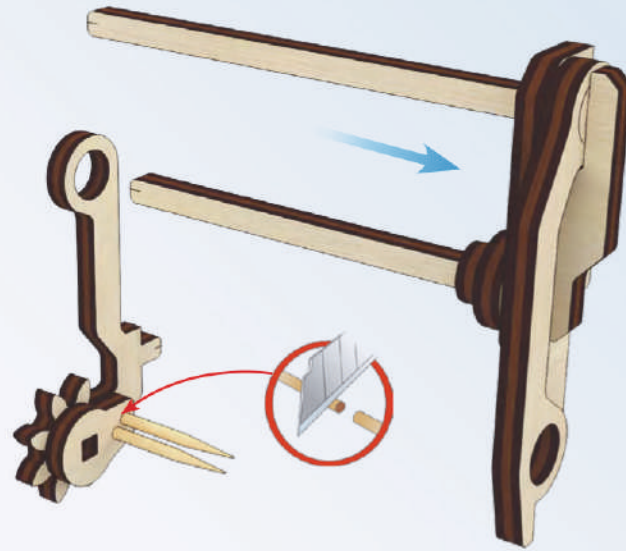
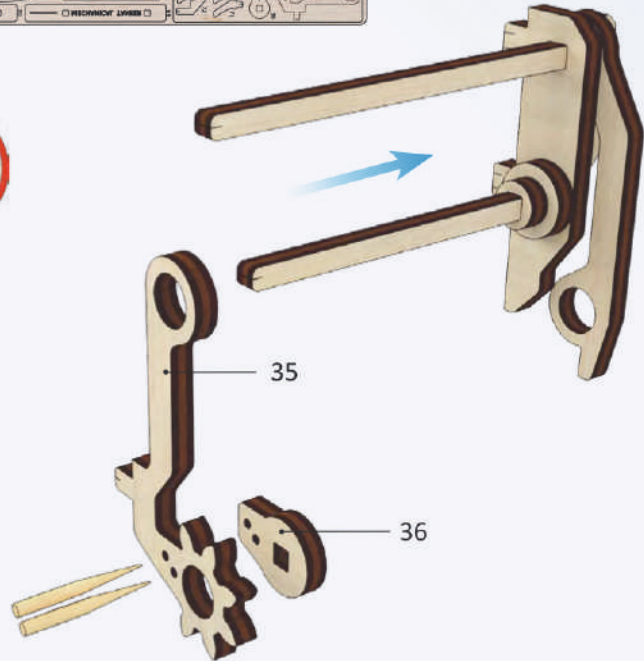
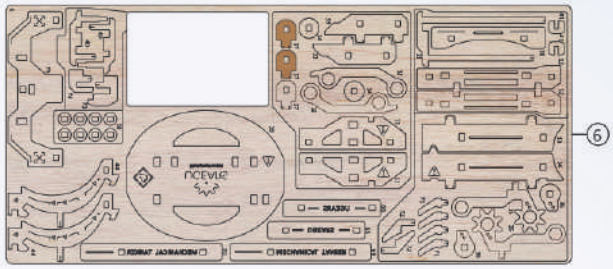

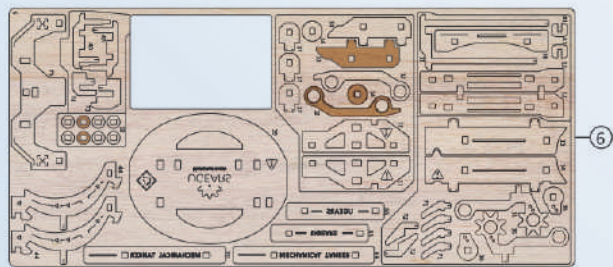

7

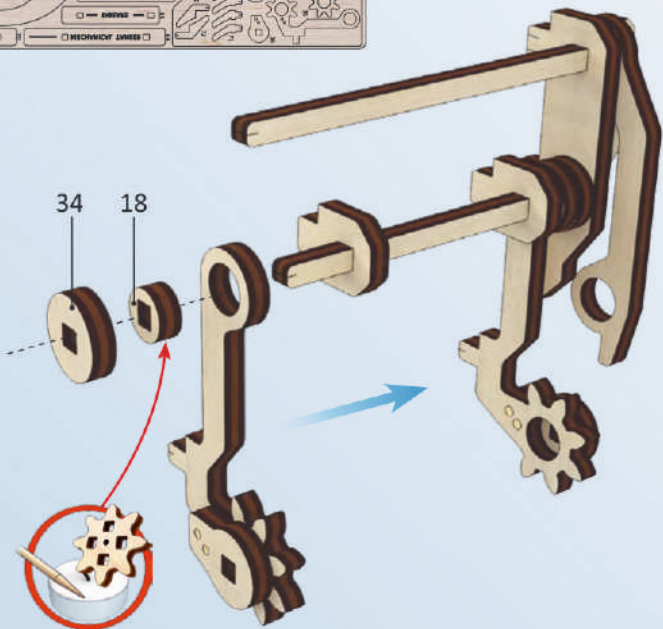

8

32

18

33

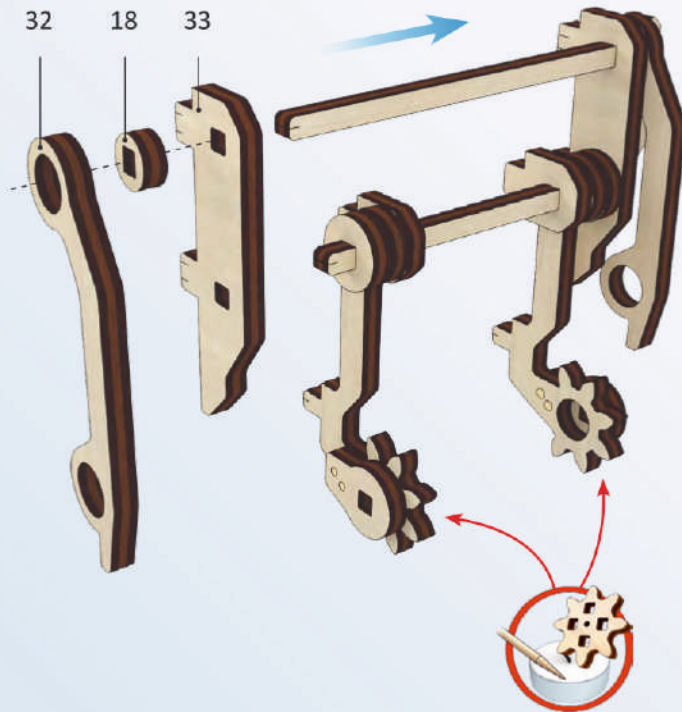

9

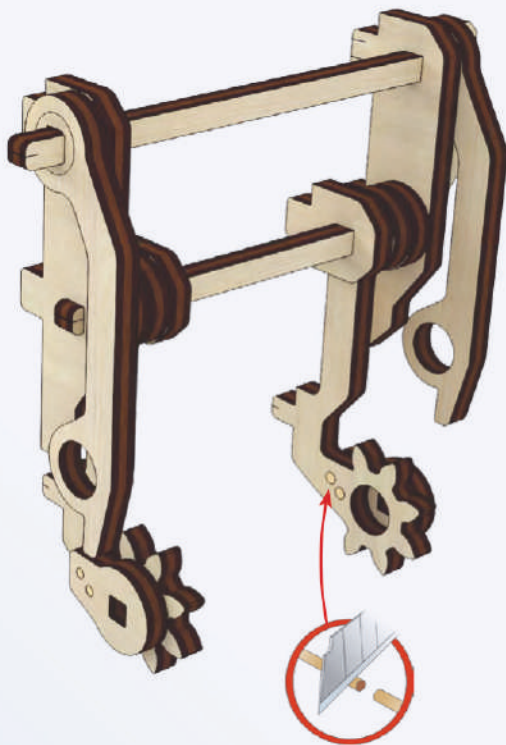



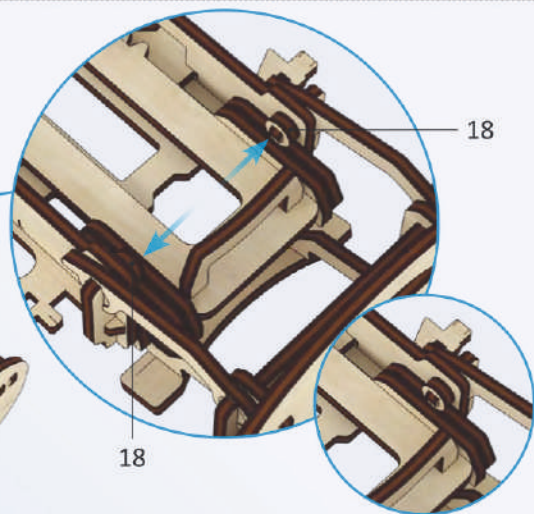
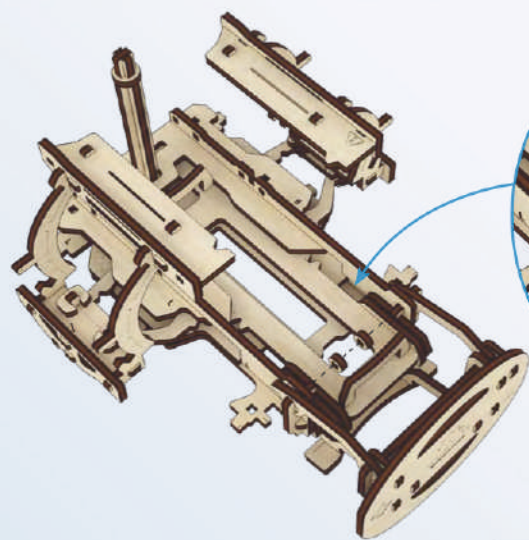
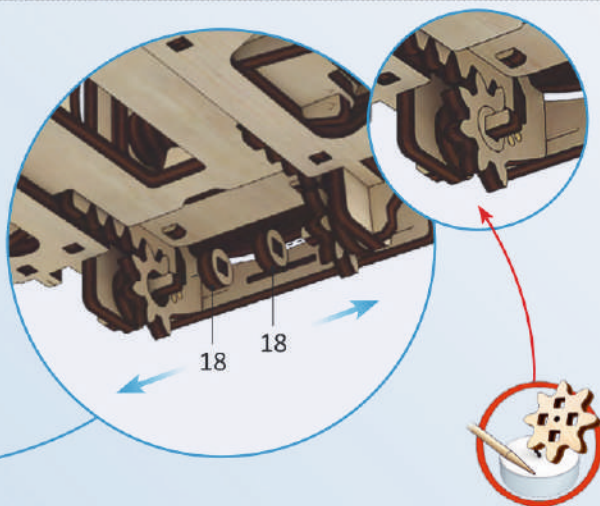
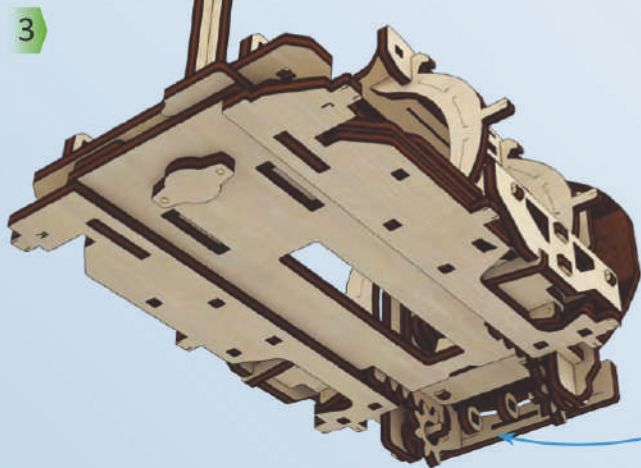
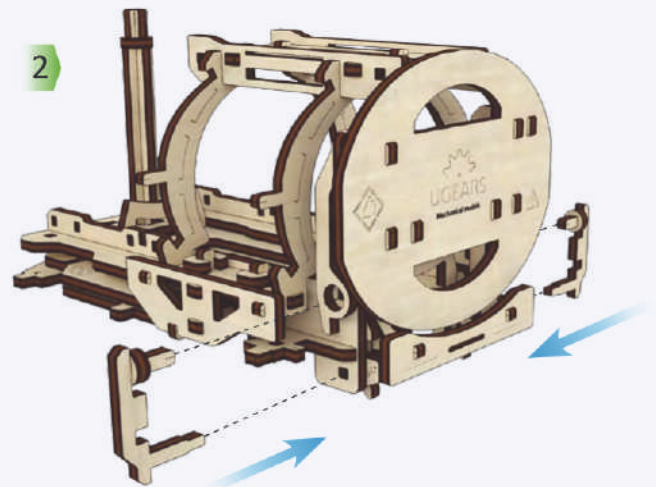
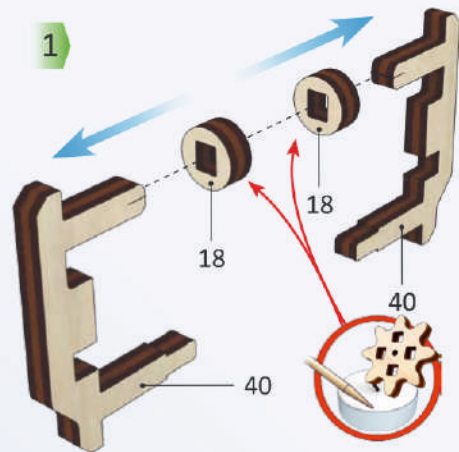
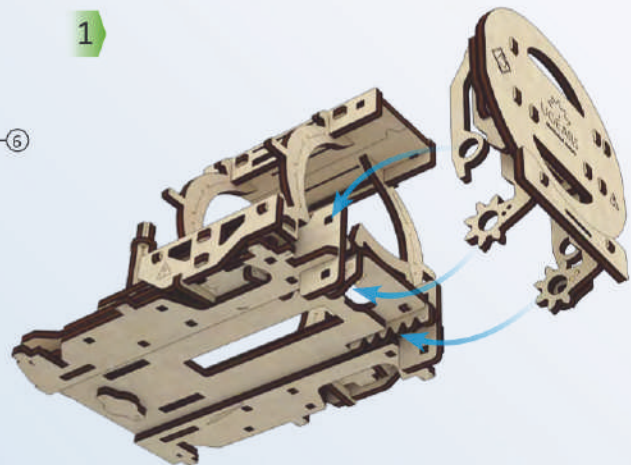
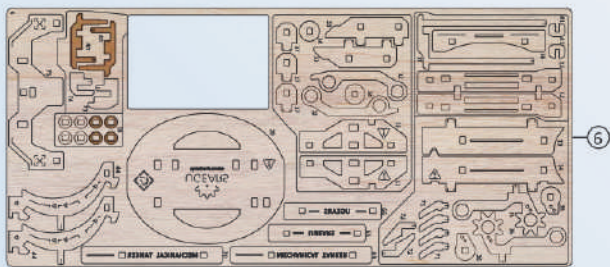



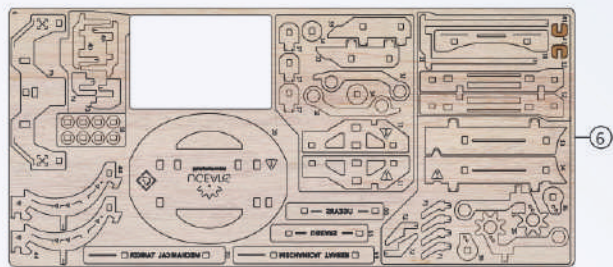

1

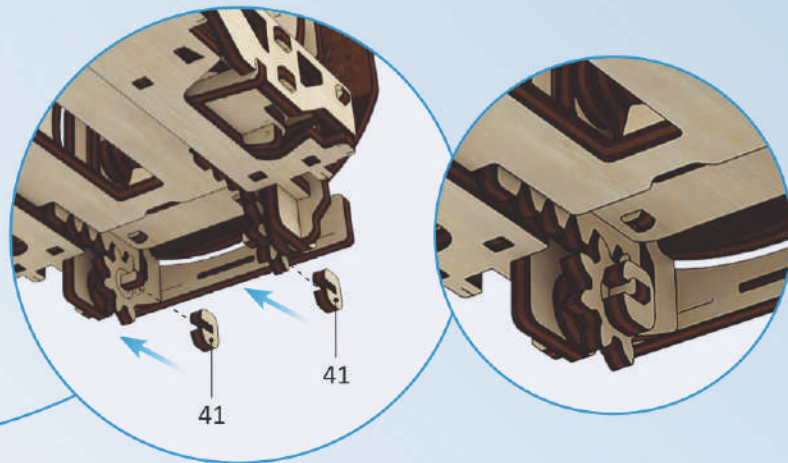
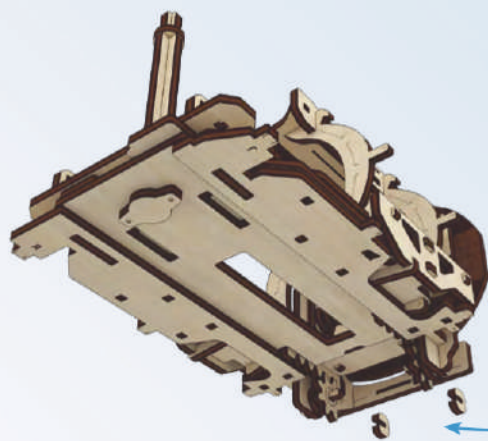

2

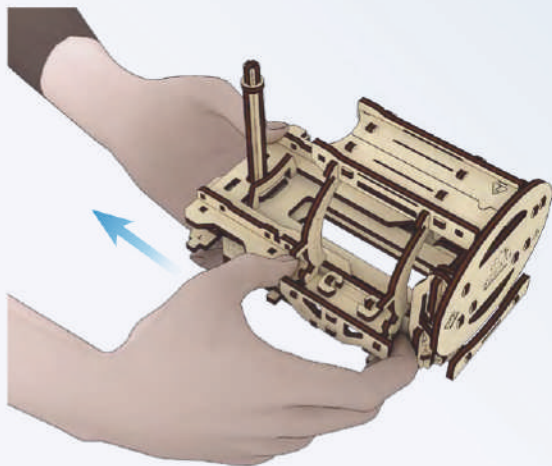

3

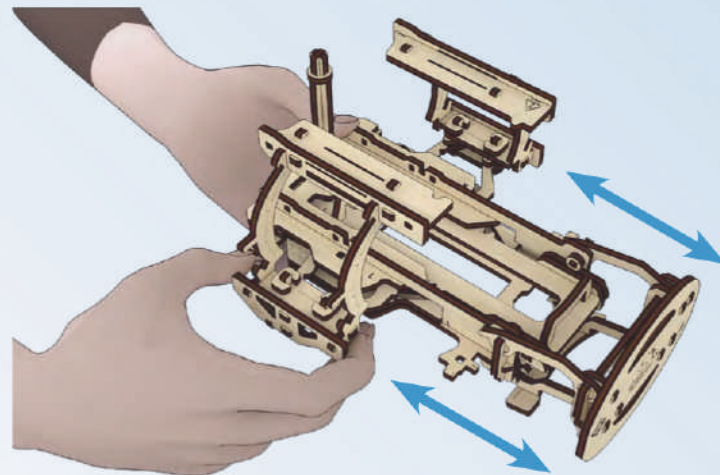

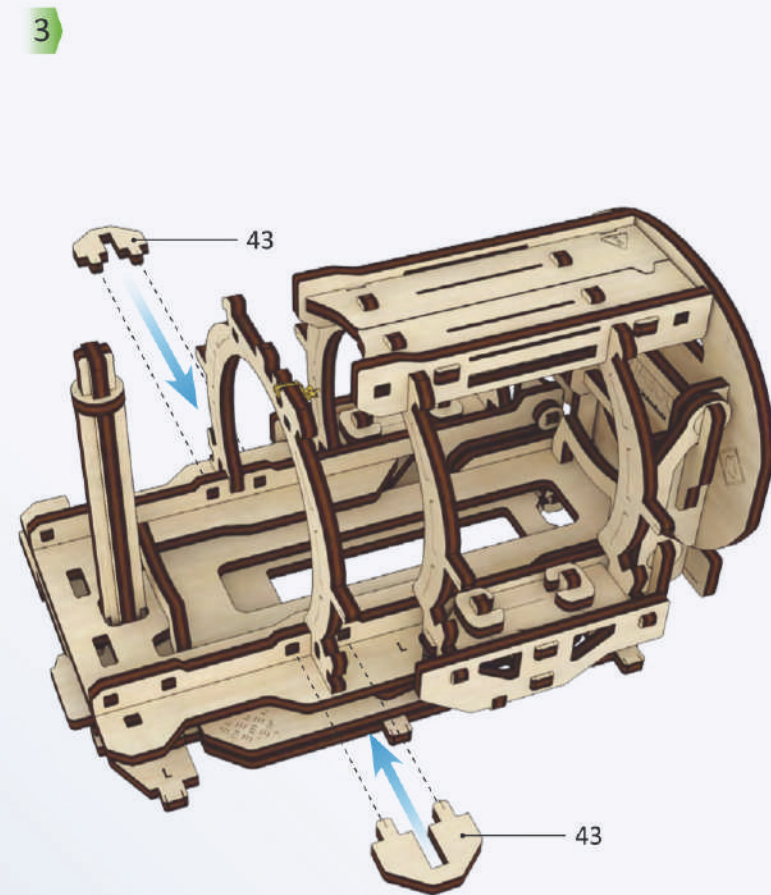
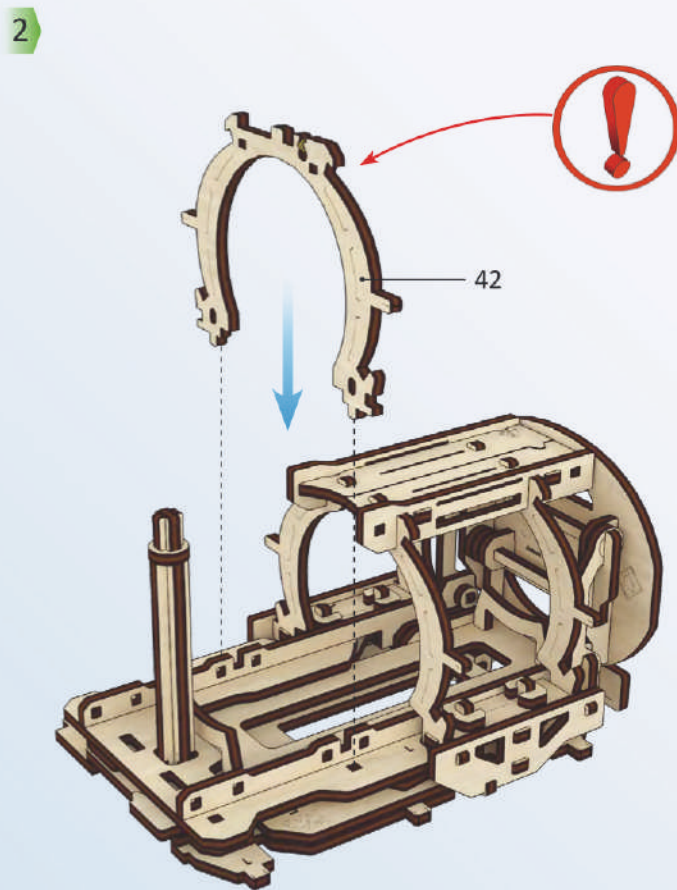
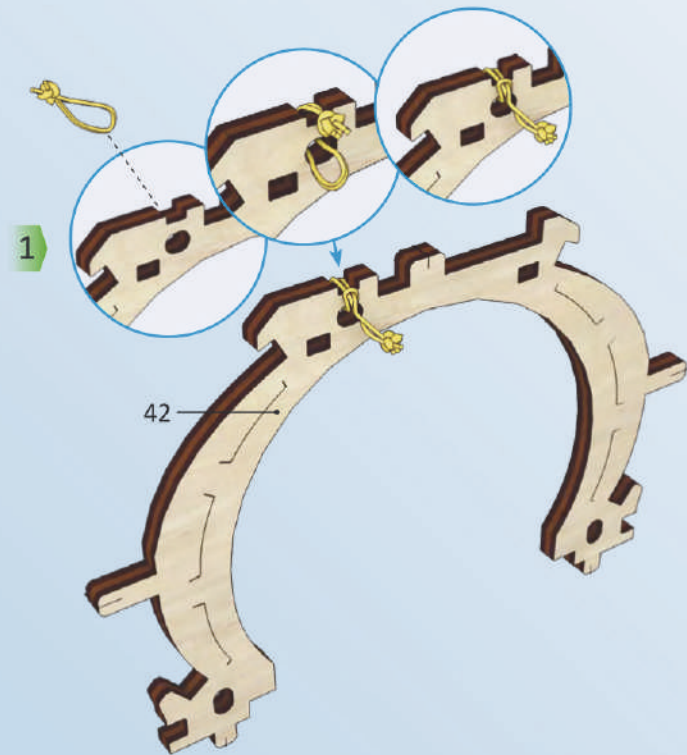
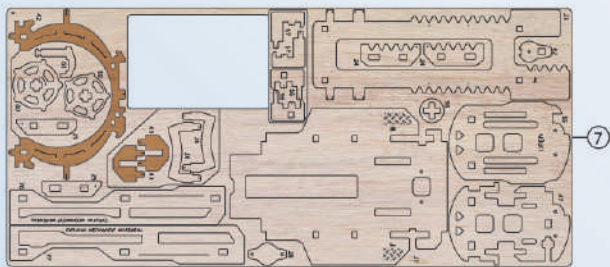

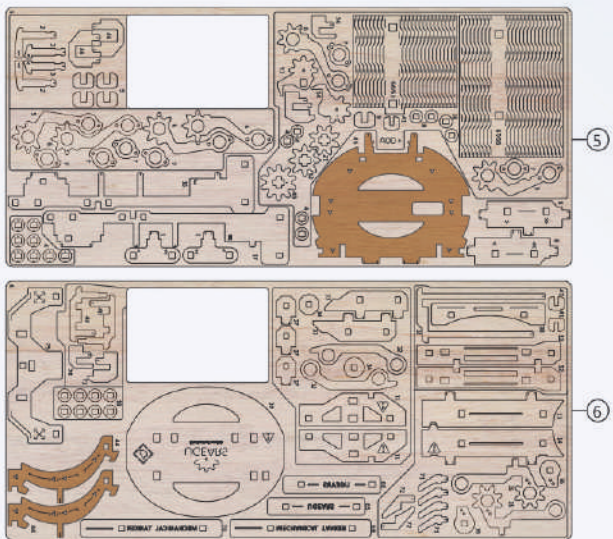

1

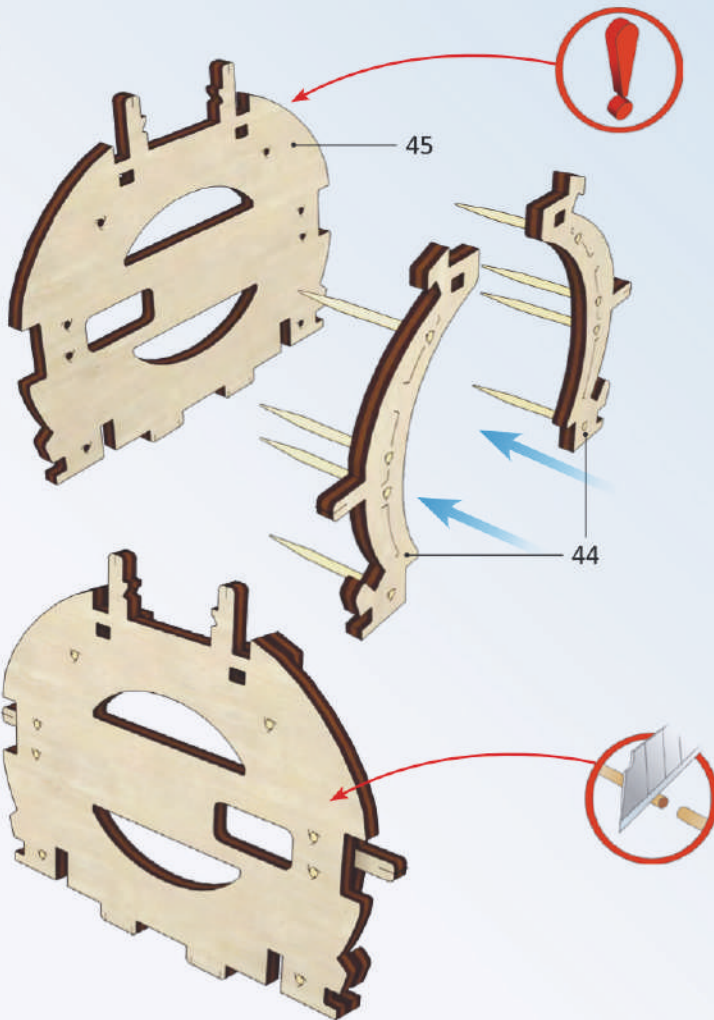

2

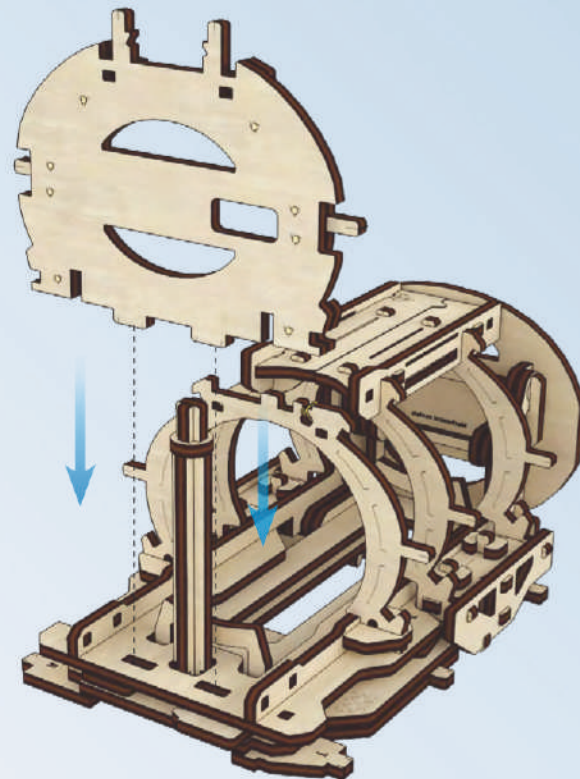

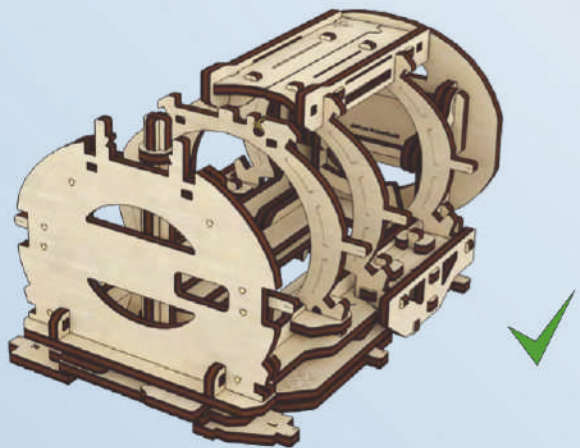
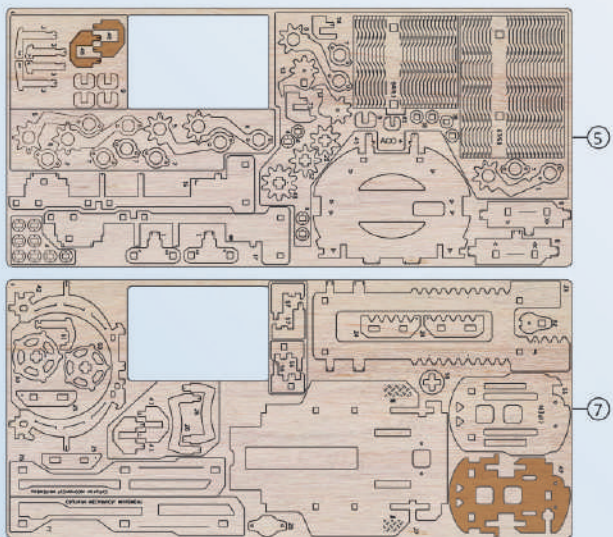

1

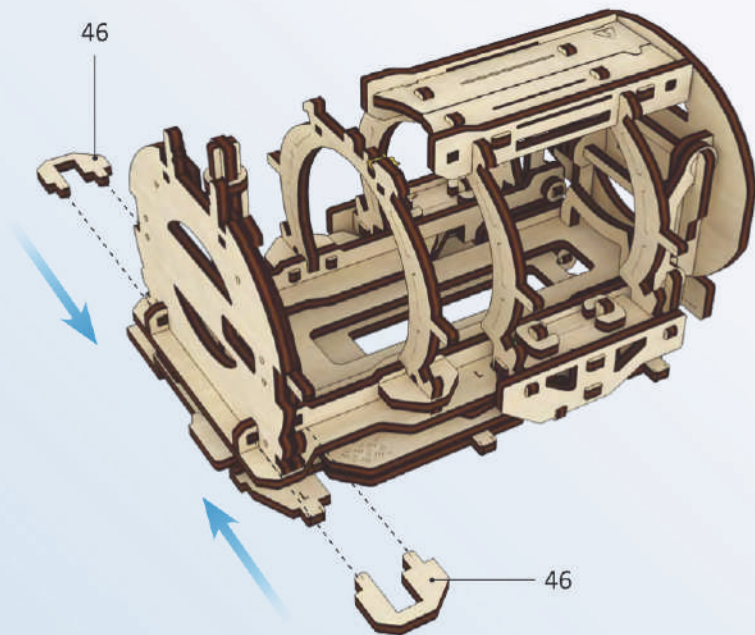

2

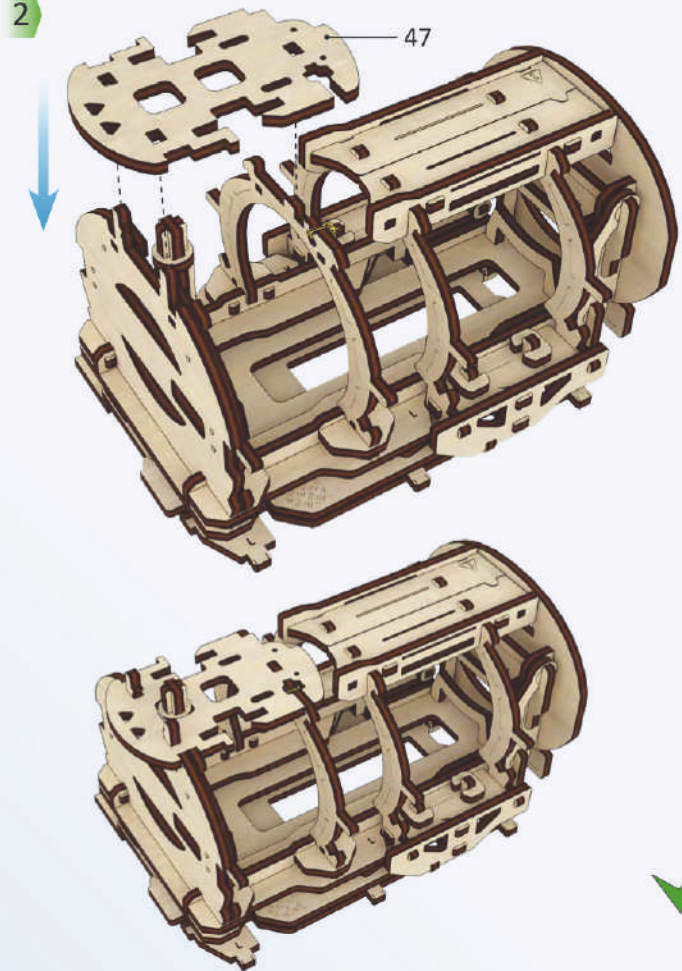

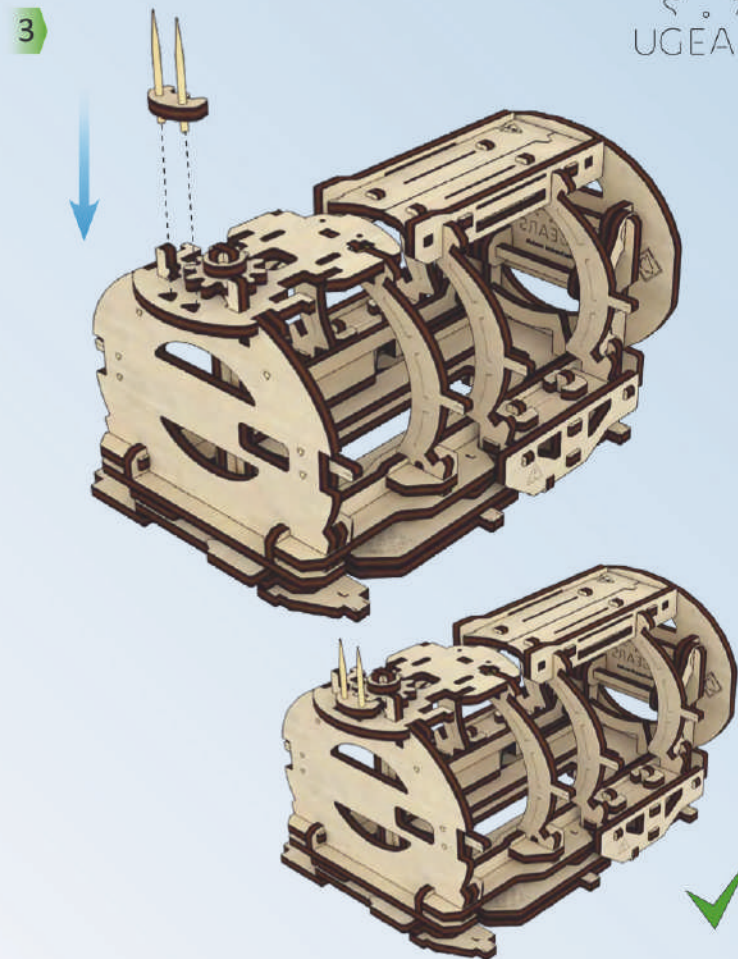
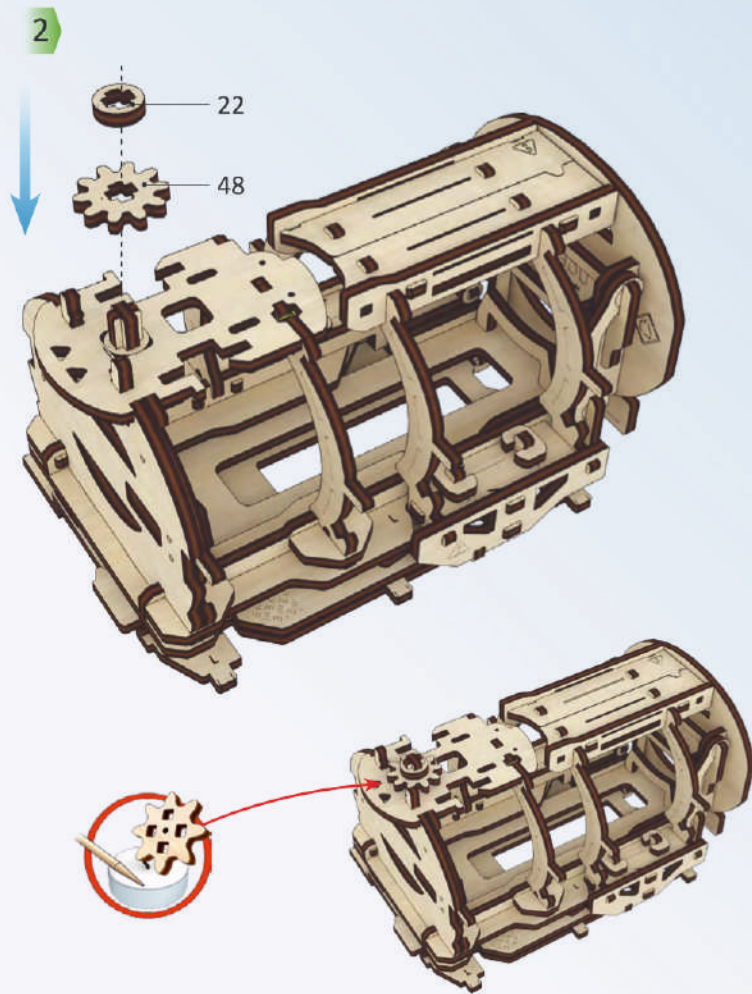
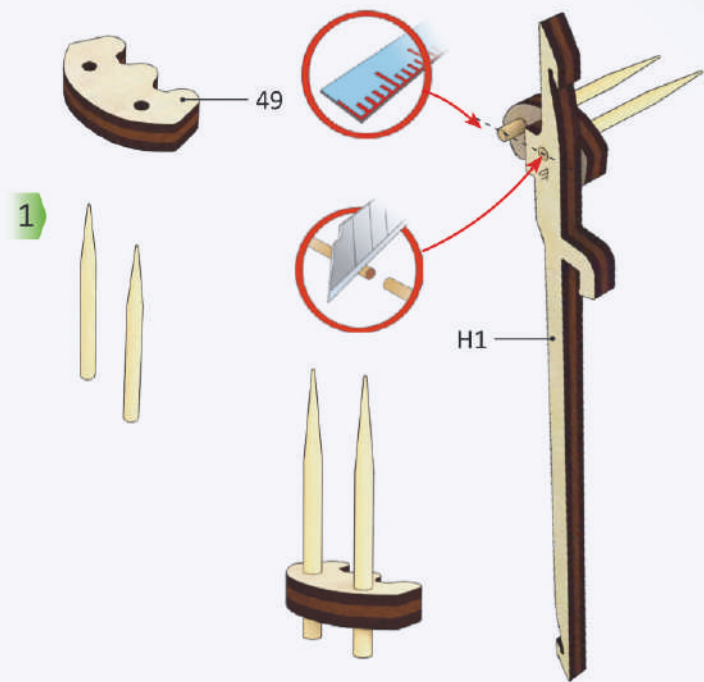
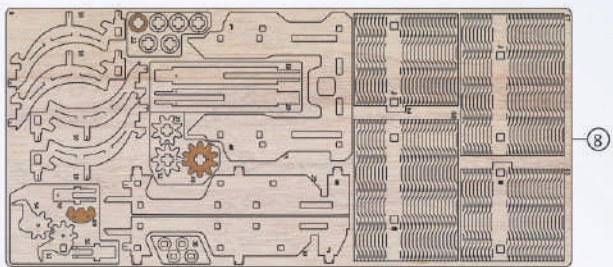

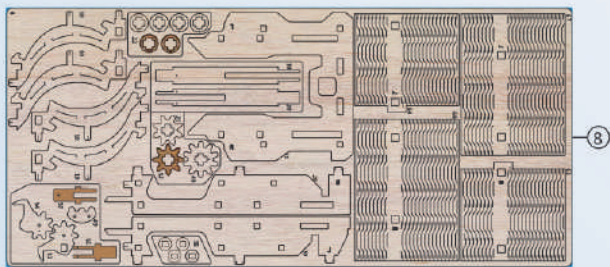

1

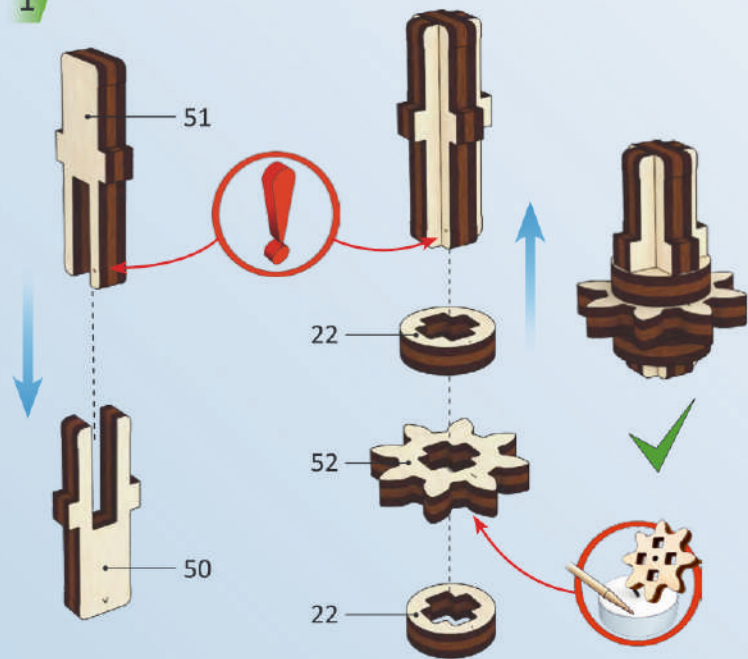

2

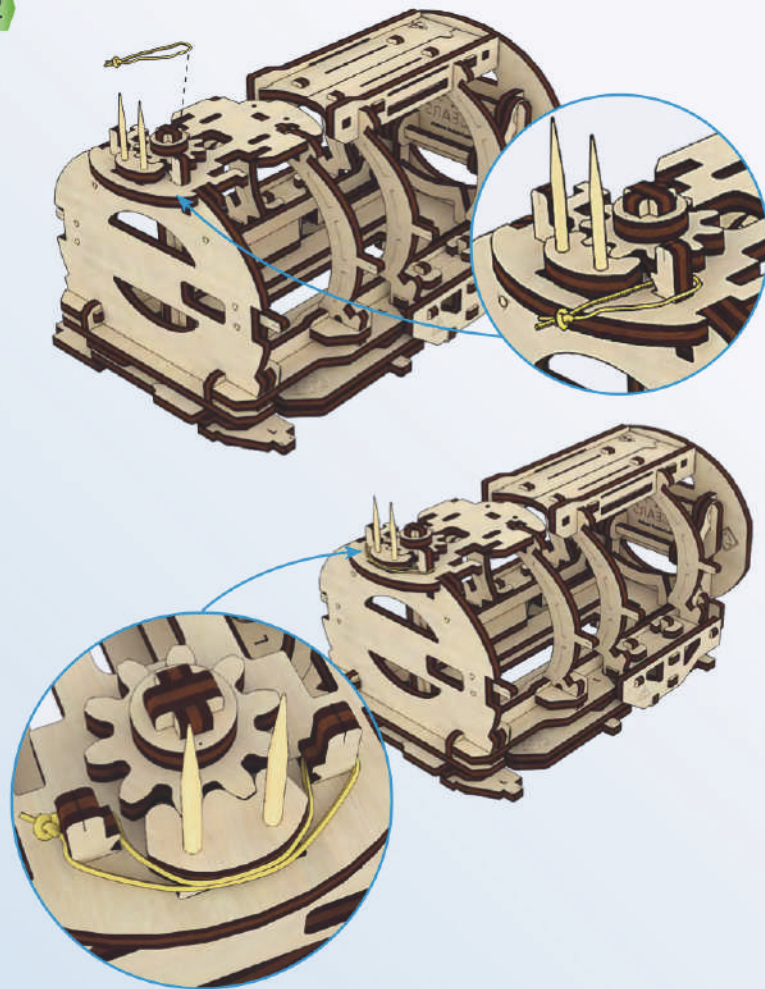

3

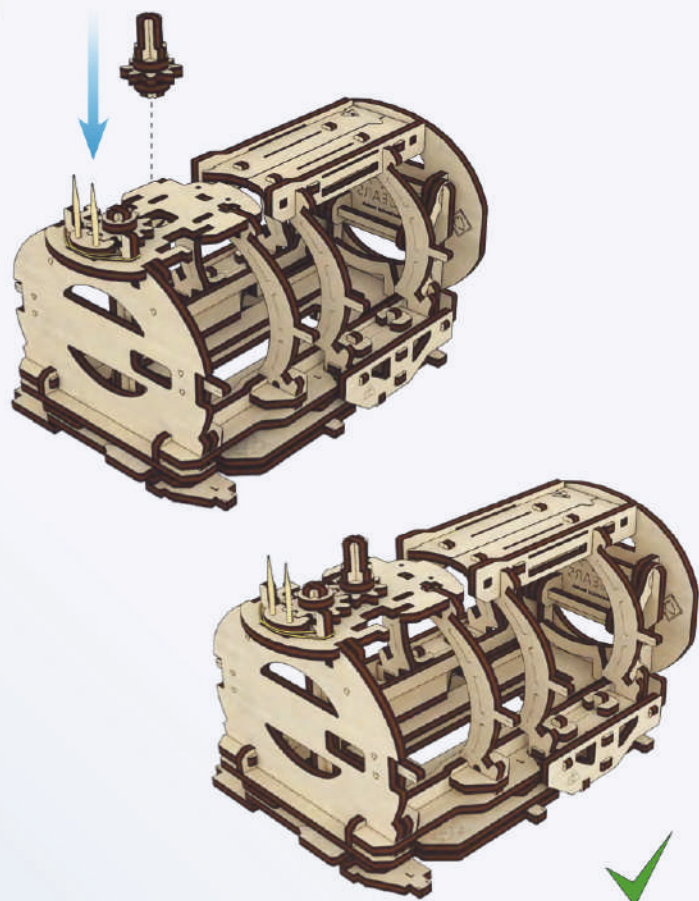

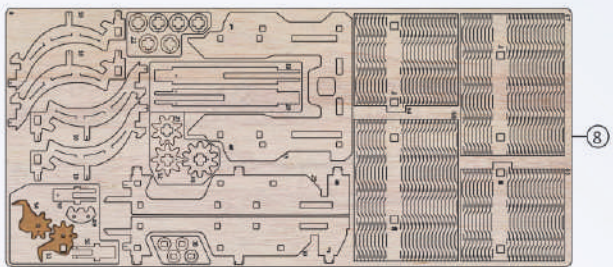

1

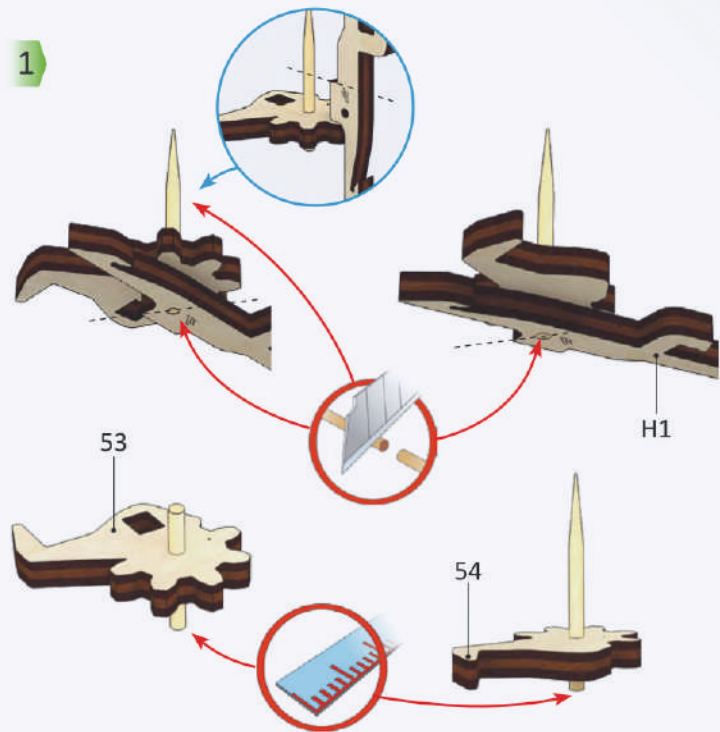

2

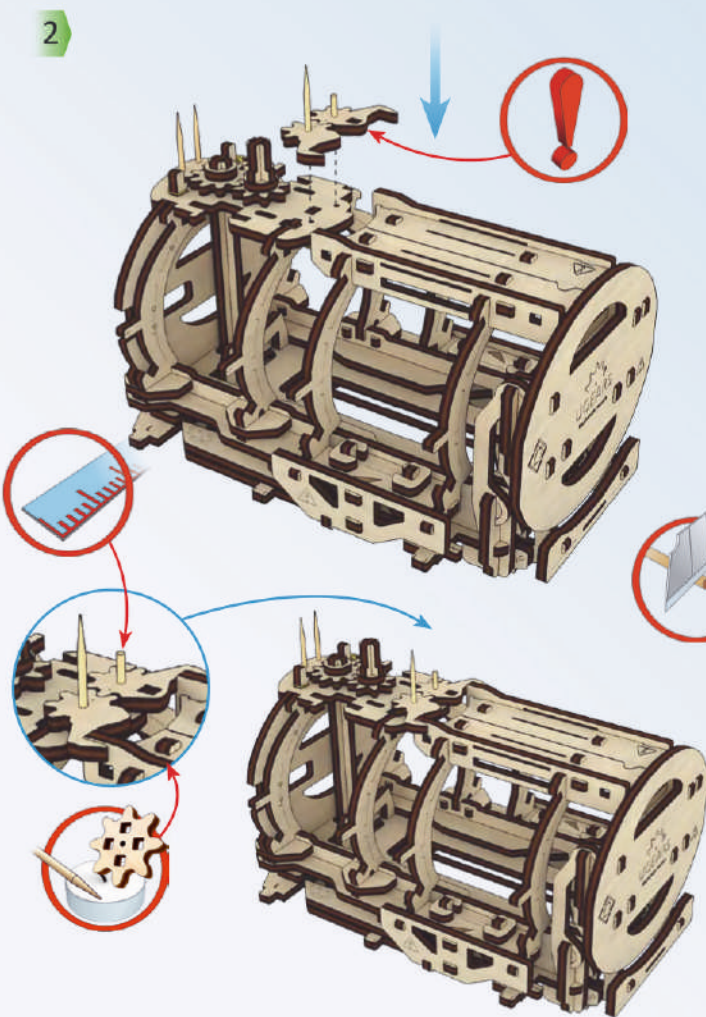

3

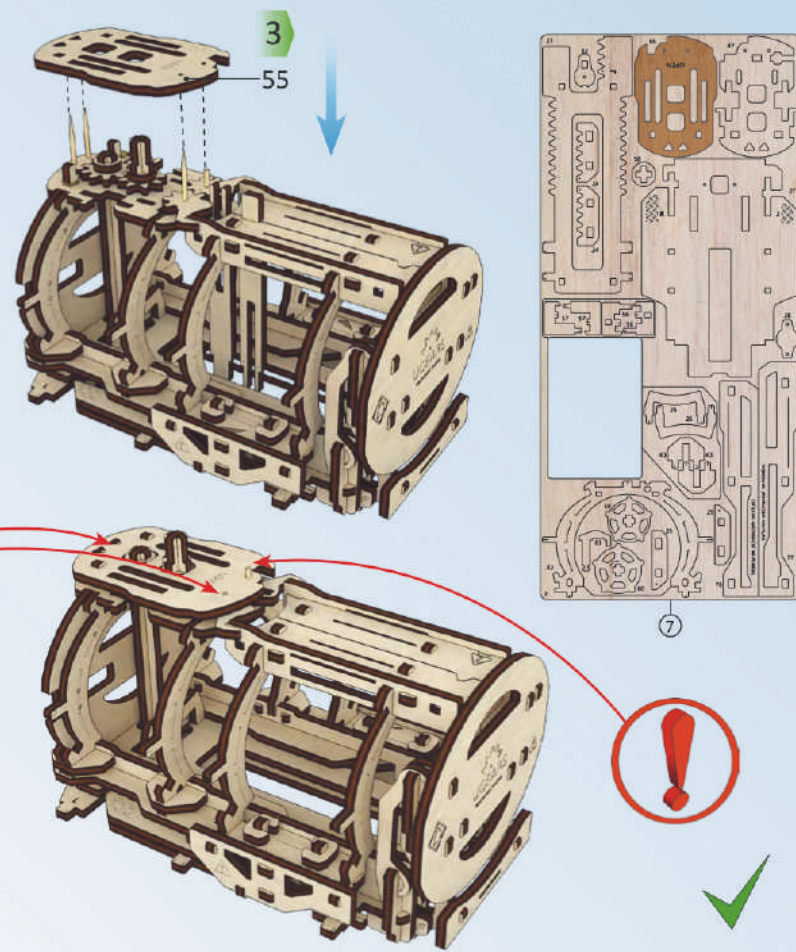

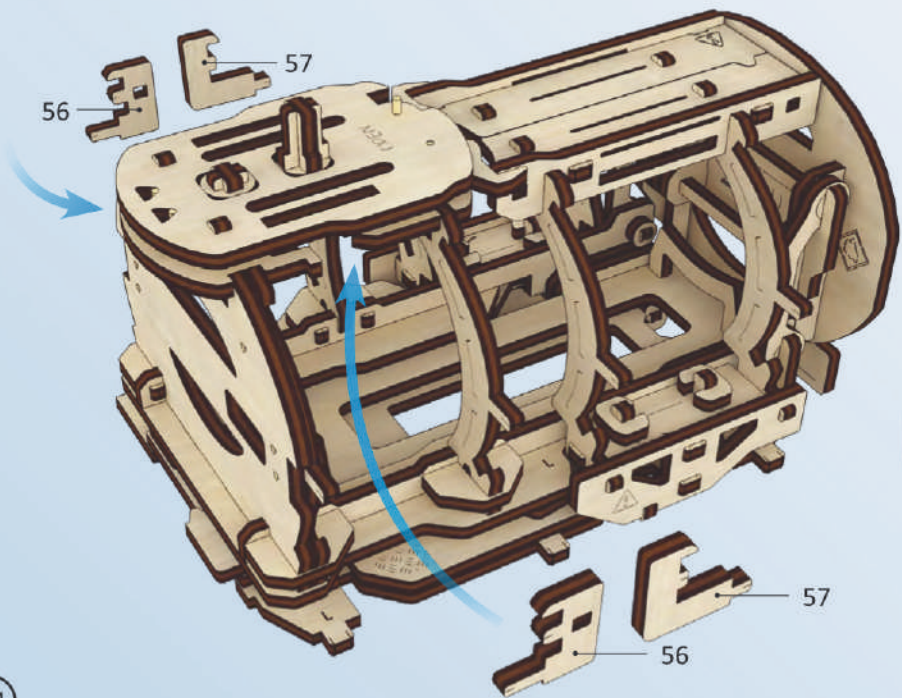
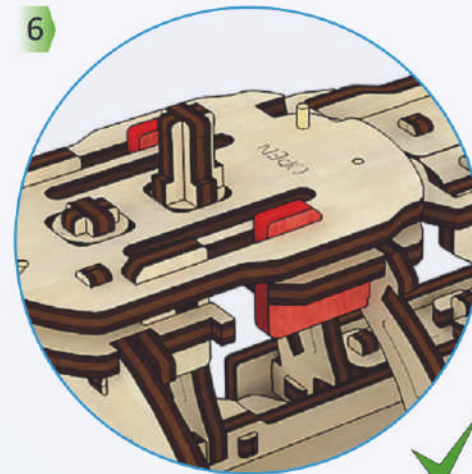
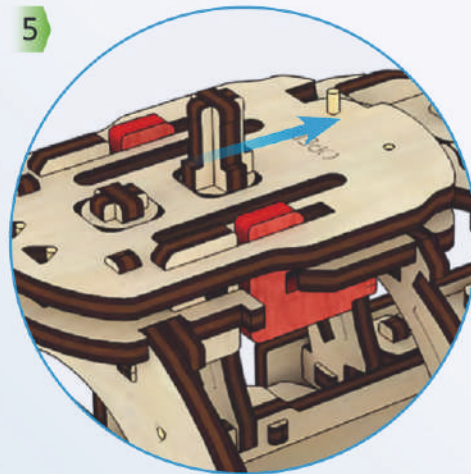
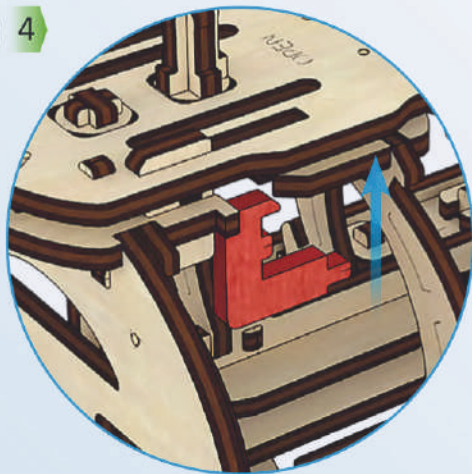
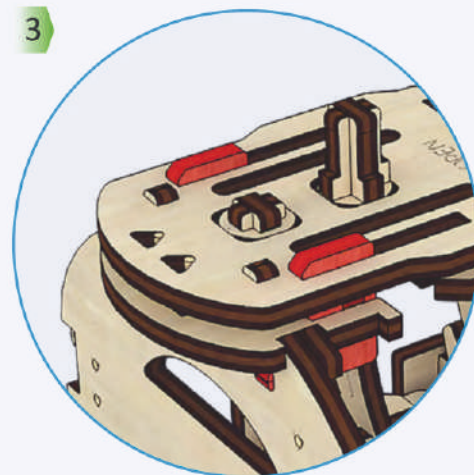
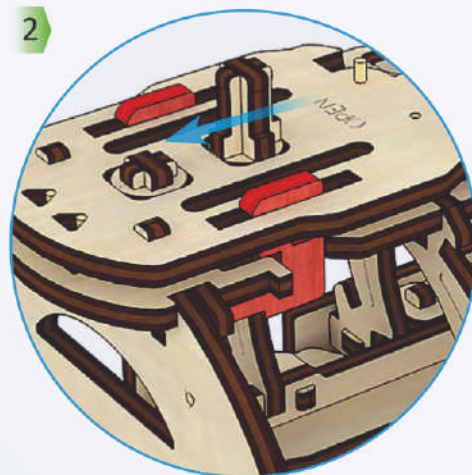
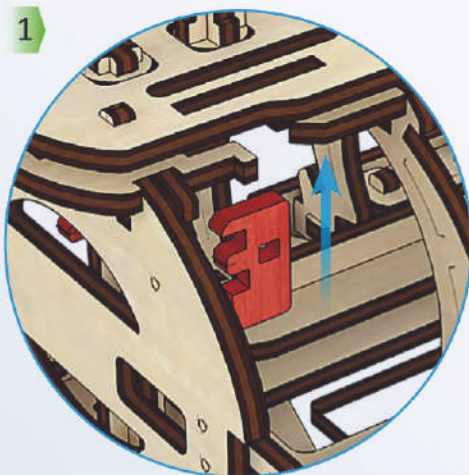
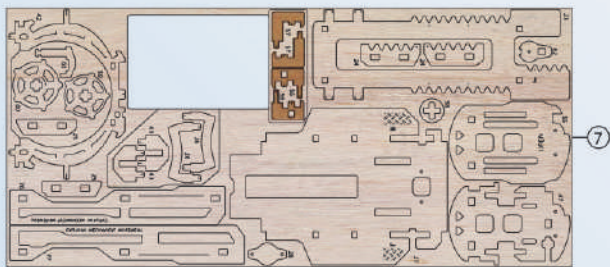



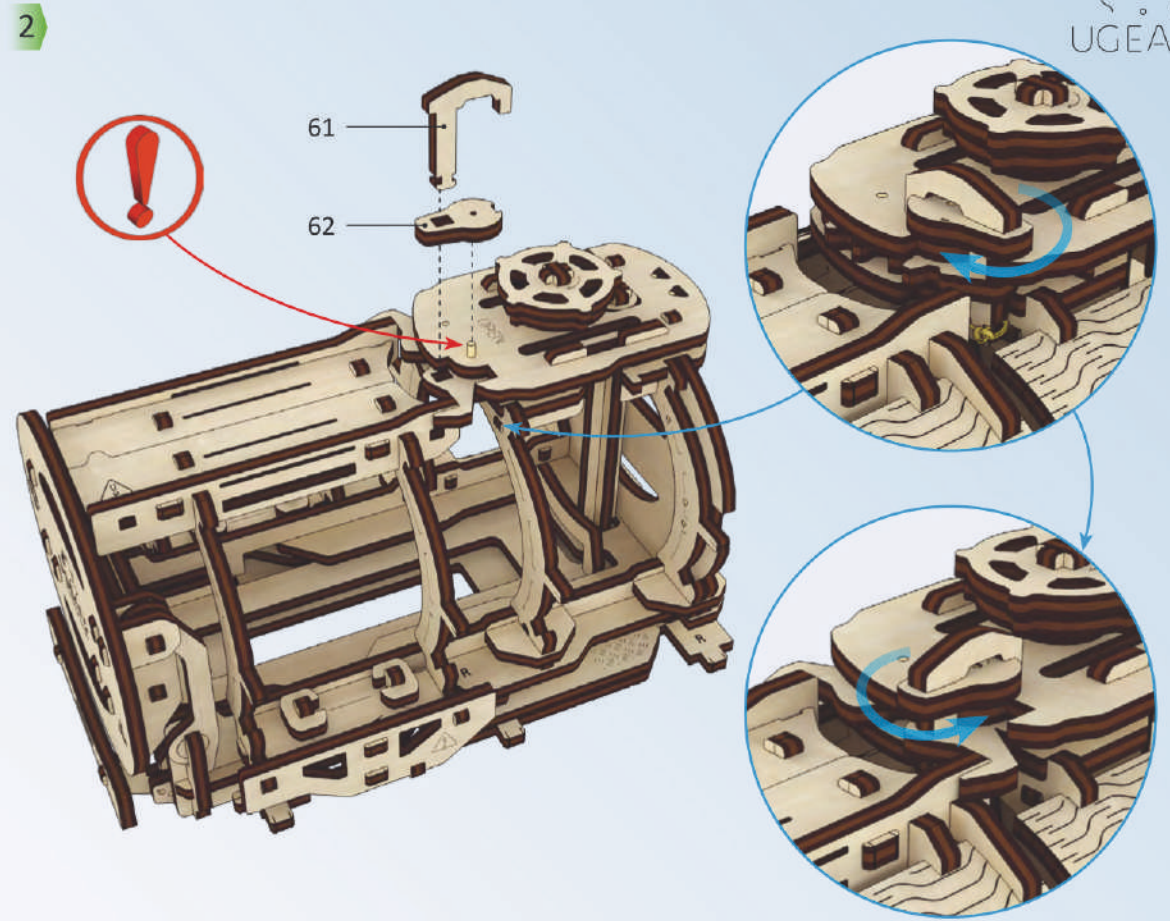
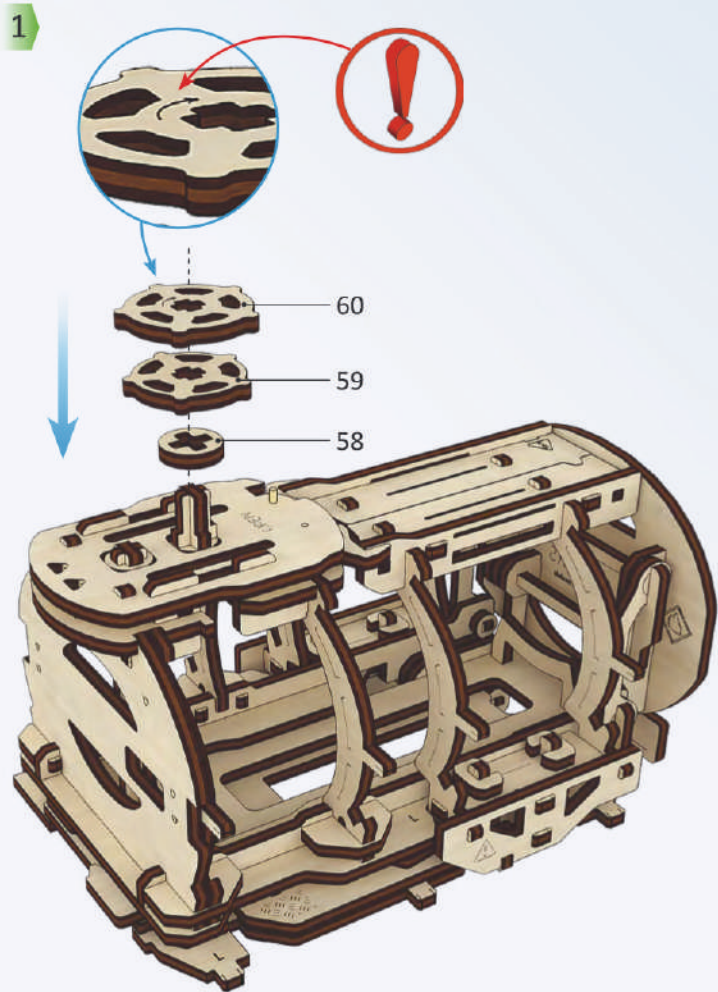
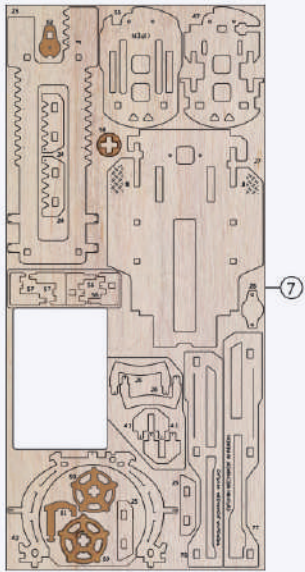

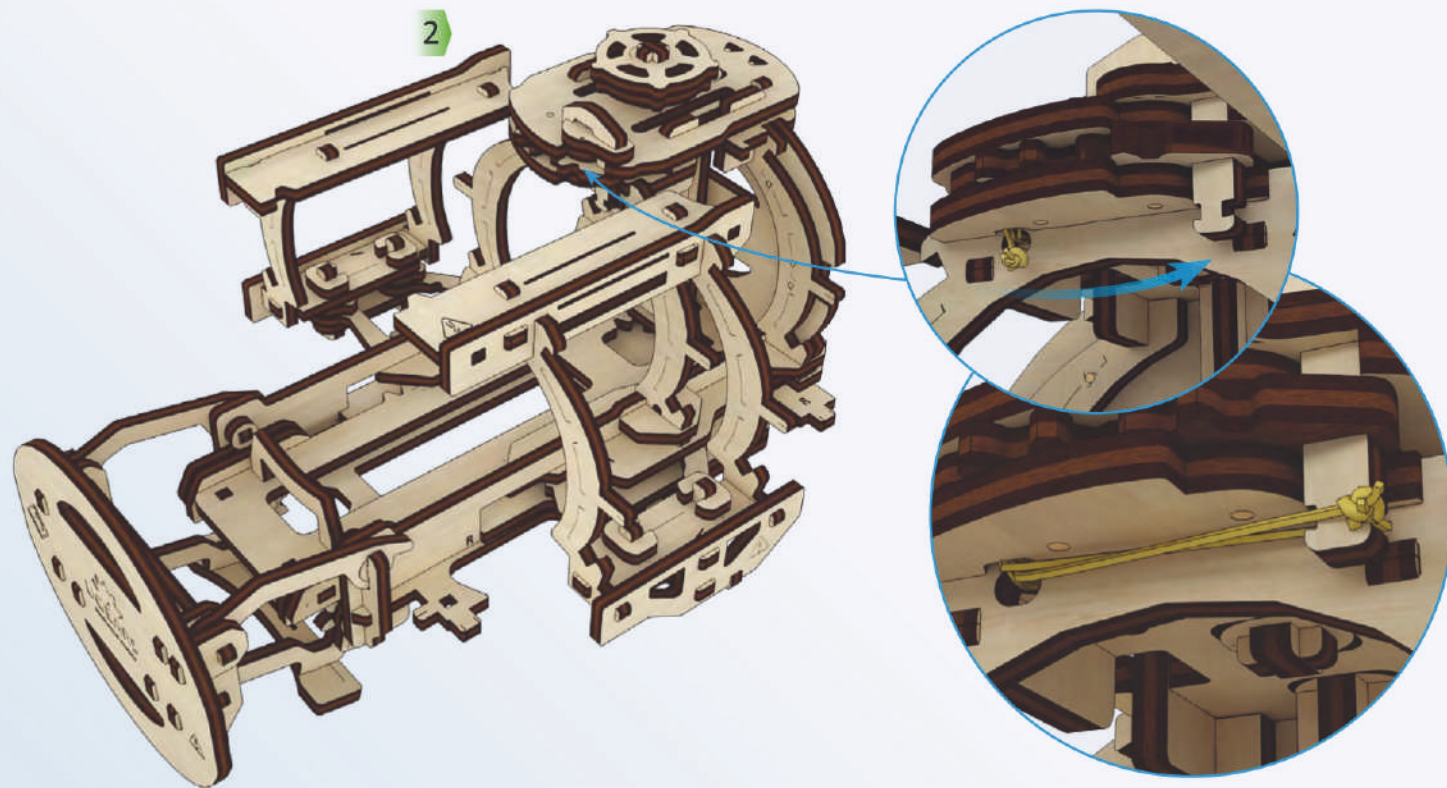
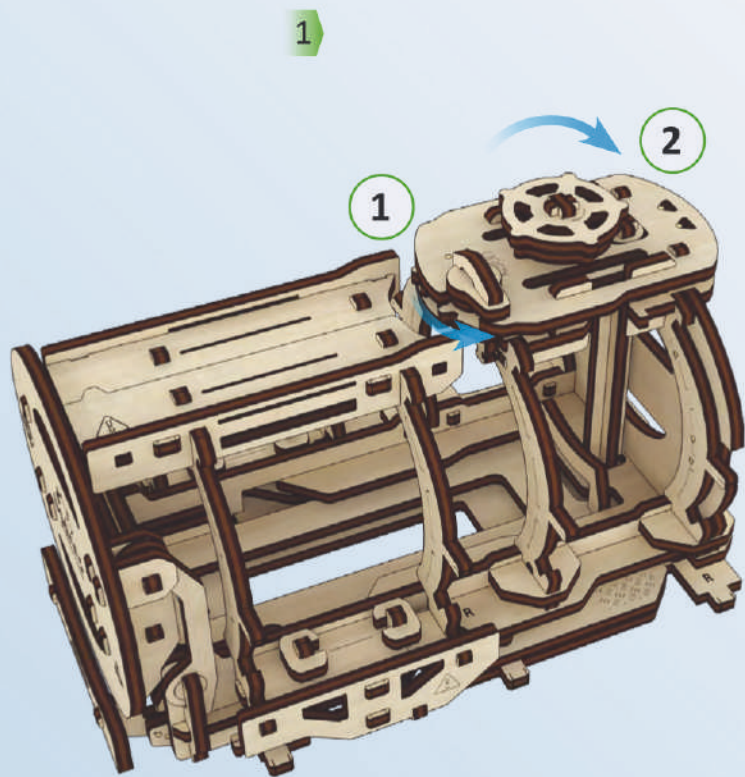

ENG Neatly turn it around. UKR Аккуратно поверніть. DEU Einmal vorsichtig umdrehen. FRA Tournez doucement. POL Starannie obrócić dookoła. SPA Cuidadosamente déle la vuelta. ITA Girare con la dovuta calma. TUR Dikkatli döndürün. RUS Аккуратно поверните. KOR 부드럽게 돌아가야 합니다. CHI 轻轻地旋动

ENG The band should be tight. UKR Гумка повинна бути натягнута. DEU Das Gummi muss gespannt sein. FRA L'élastique doit être serré. POL Gumka powinna być naciągnięta. SPA El elástico debe ser ajustado. ITA L'elastico deve essere teso a sufficienza. TUR Lastik gerilmiş olmalıdır. RUS Резинка должна быть натянута. KOR 고무밴드 장력이 팽팽해야 합니다. CHI 橡皮筋必须拉紧

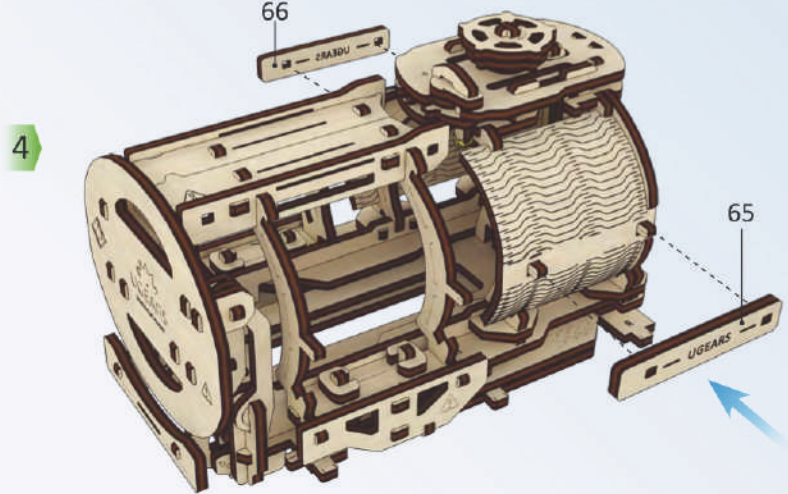
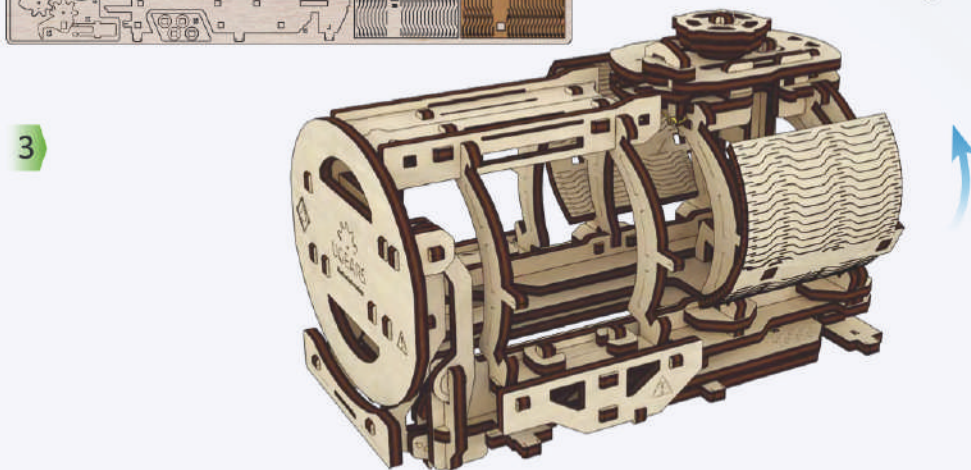
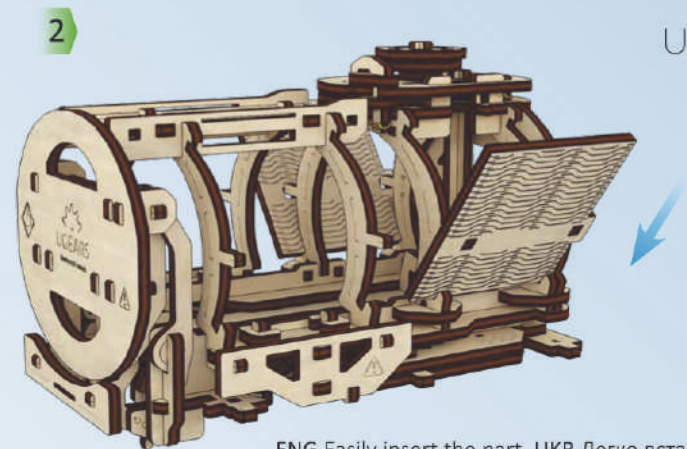
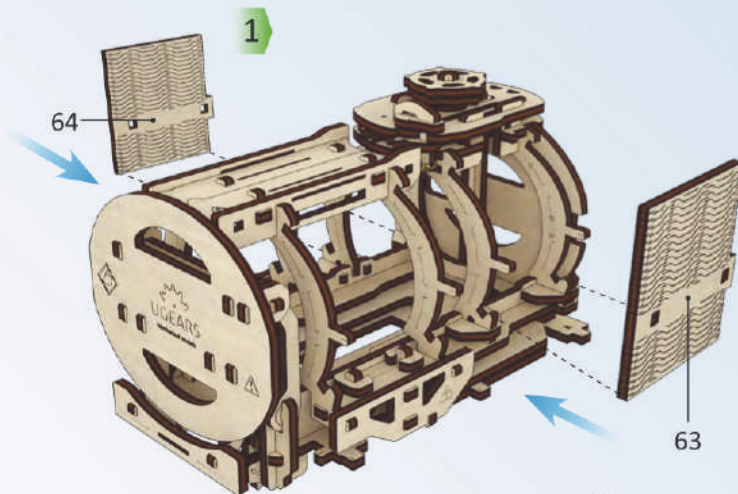
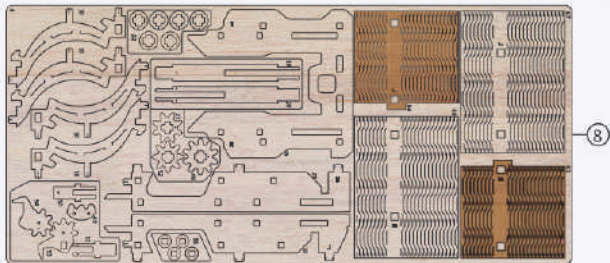
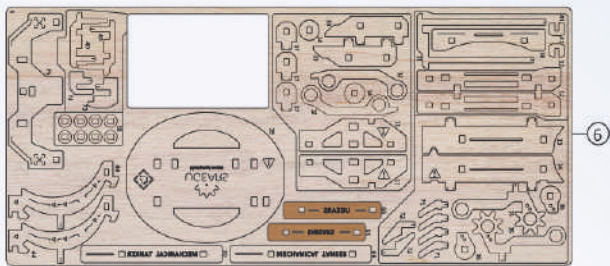

ENG Easily insert the part. UKR Легко вставте деталь.  
 DEU Das Bauteil leicht einsetzen. FRA Insérez facilement la partie.  
 POL Ostrożnie wymienić część. SPA Introduzca suavemente el detalle.  
 ITA Inserire il complemento aggiuntivo con facilità. TUR Parçayı kolay yerleştirin.  
 RUS Легко установите деталь. KOR 부품을 살짝 끼워주세요. CHI 轻松地插入零件

ENG Caution! Do not bend strongly! UKR Обережно! Сильно не згинати!  
 DEU Vorsicht! Nicht zu stark verbiegen! FRA Attention! Ne pas plier avec force!  
 POL Uwaga! Nie zginać mocno! SPA ¡Precaución! No doblar fuertemente!  
 ITA Attenzione! Non piegare con forza! TUR Dikkat! Fazla bükmeyin!  
 RUS Осторожно! Сильно не сгибать! KOR 주의! 너무 강하게 구부리지 마세요.  
 CHI 注意! 不要过度用力弯曲!

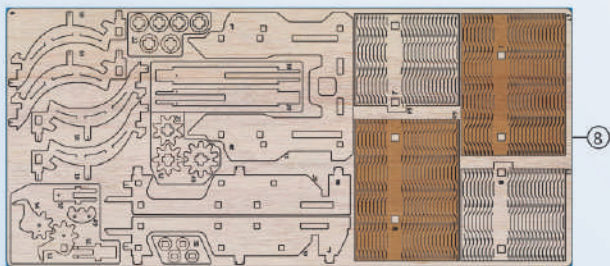

2

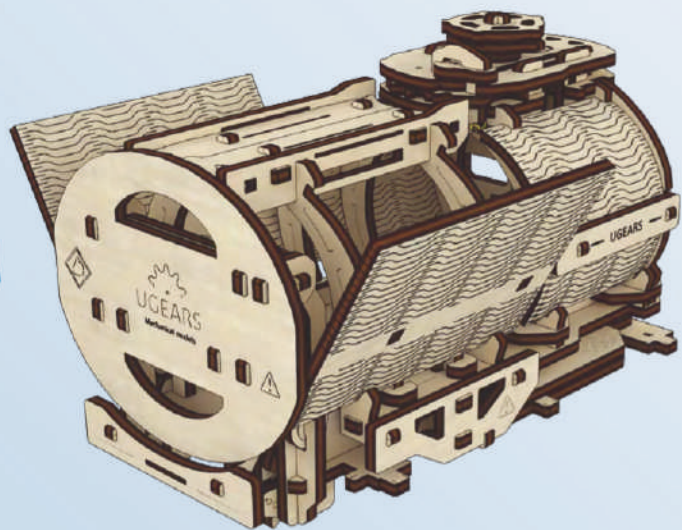

1 68

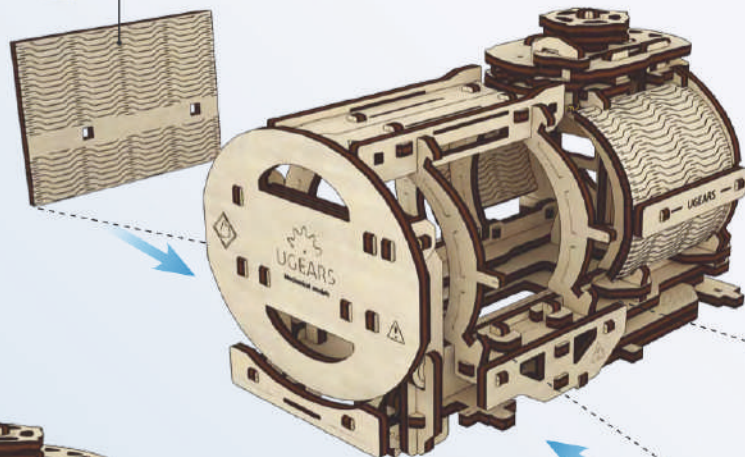

67

3

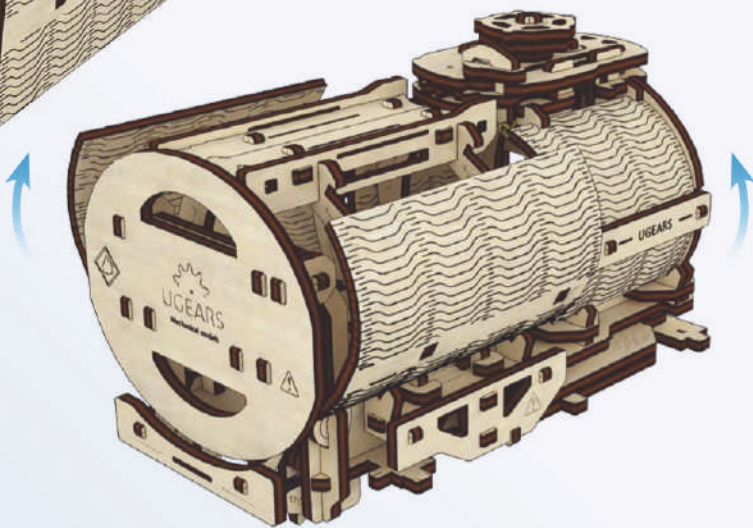

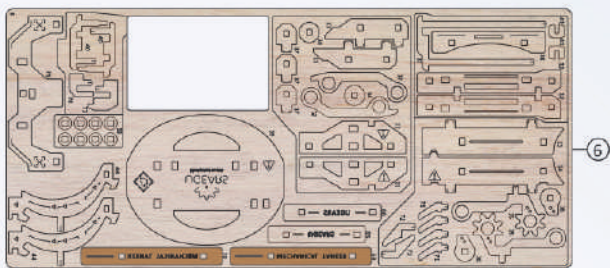

1

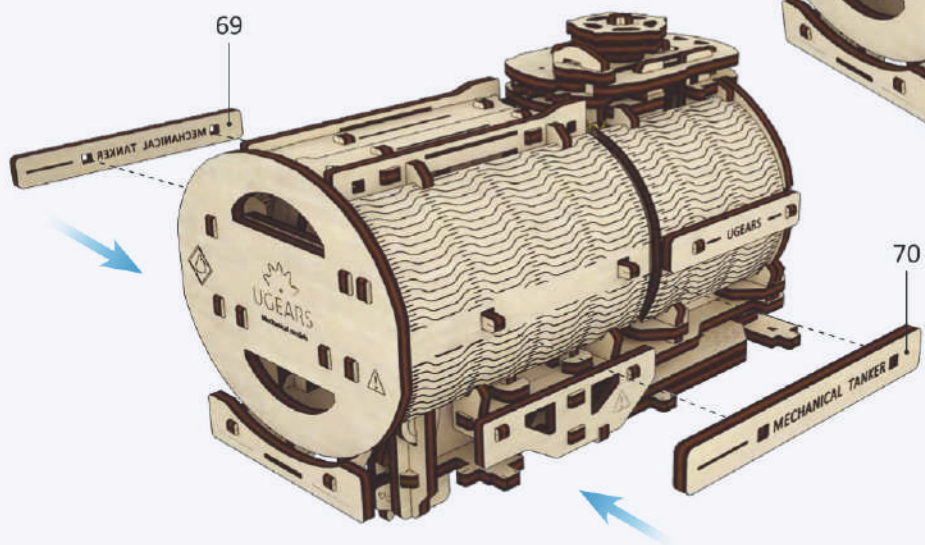

2

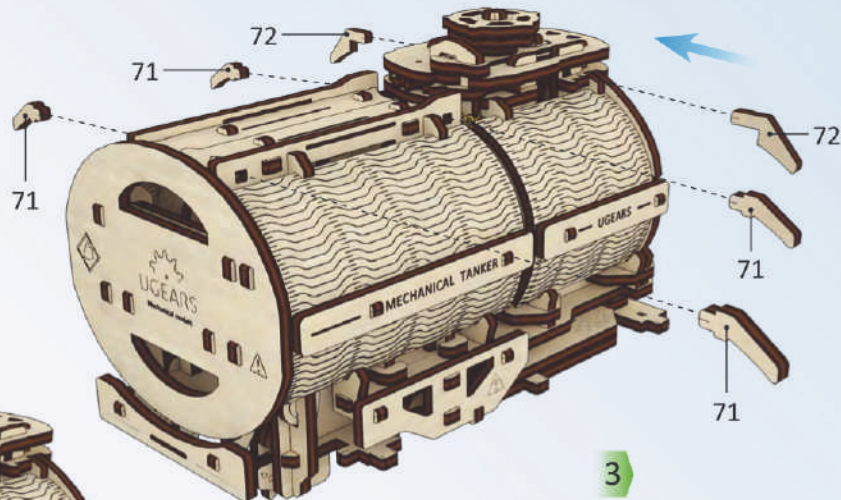

3

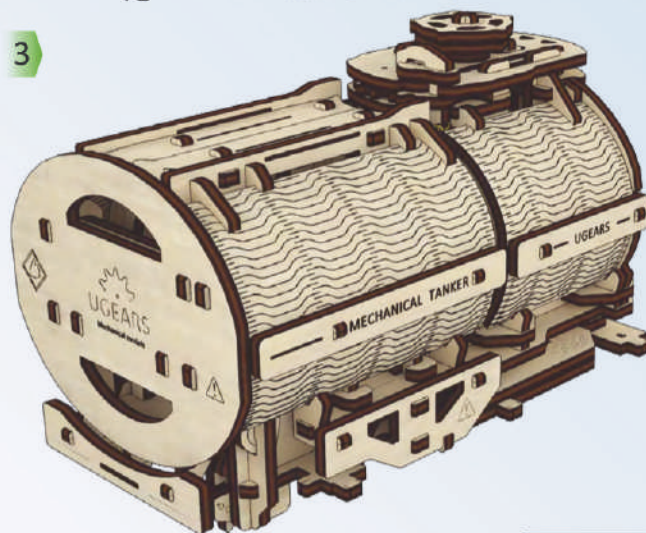

ENG The part can be replaced with an additional one from the set or alternative details may be cut out of the paper. Look page 33. UKR Деталь можна замінити на запасну з набору або вирізати альтернативні паперові деталі. Дивіться с. 33. DEU Das Bauteil kann durch eines aus den Ersatzteilen ersetzt werden oder aus dem Papier geschritten werden. Siehe Seite 33. FRA La partie peut être remplacée par une autre de l'ensemble ou d'autres détails peuvent être découpés sur le papier. Regardez à la page 33. POL Część można wymienić na zapasową z zestawu, lub wyciąć zastępczą z papieru. Patrz strona 33. SPA La pieza puede ser reemplazada con una otra adicional del conjunto, o los detalles alternativos pueden ser cortados del papel. La hoja a la página 33. ITA Si puo' sostituire il complemento del camion con un altro dal set si puo' anche tagliare un dettaglio alternativo dalla carta. Guarda pag. 33. TUR Parçayı kittede bulunan yedek parçayla değiştirebilirsiniz veya alternatif kağıt parçaları kesebilirsiniz. 33. Sayfaya bakınız. RUS Деталь можно заменить на запасную из набора. Или вырезать альтернативные бумажные детали. Смотрите с. 33. KOR 해당 부품은 세트에 포함된 여유 부품이나 33페이지의 종이를 잘라 대체할 수 있습니다. CHI 该零部件可以用该套备件替换，或者可以剪出替代的纸造部件。参见第33页。

1

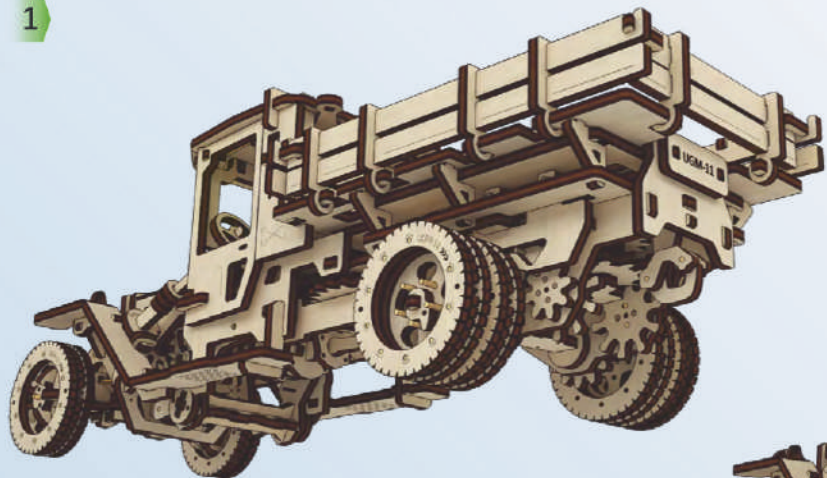

2



3

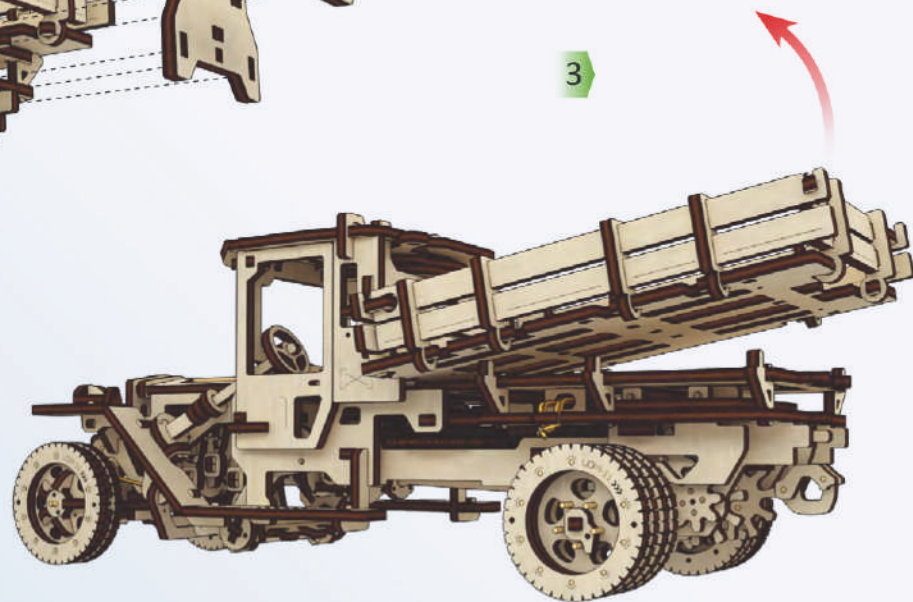

ENG Carefully remove the car body. UKR Акуратно зніміть кузов. DEU Entfernen Sie vorsichtig den Pritschenaufbau. FRA Retirez délicatement la carrosserie du camion. POL Delikatnie zdjąć karoserię. SPA Extraiga cuidadosamente el cuerpo del coche. ITA Rimuovere il cassone con la dovuta calma. TUR Römorku dikkatlice çıkarılın. RUS Аккуратно демонтируйте кузов. KOR 적재함을 조심스럽게 분리해 주세요. CHI 小心地拆卸车体。

1

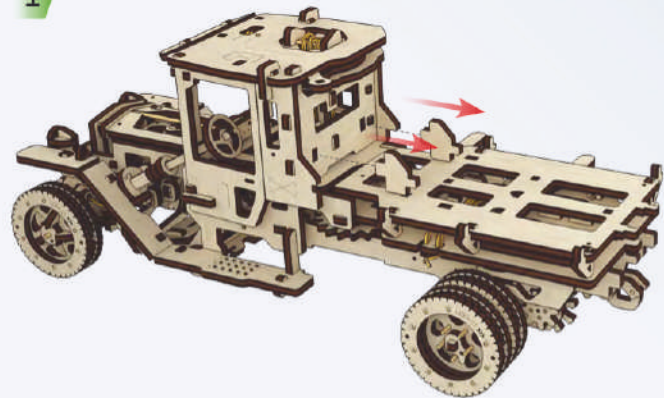

2

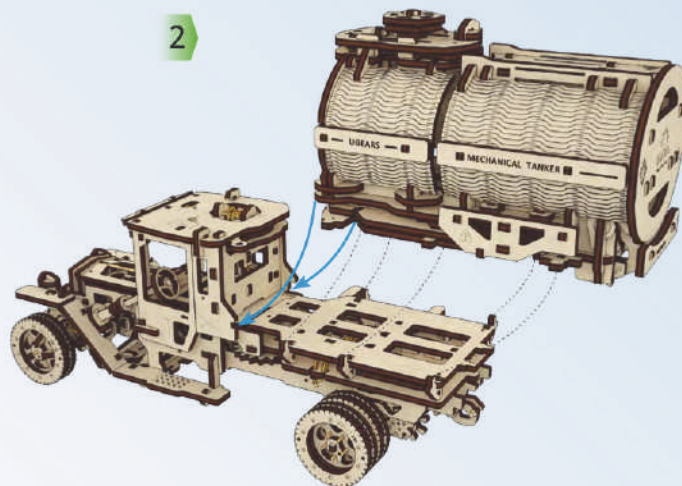

3

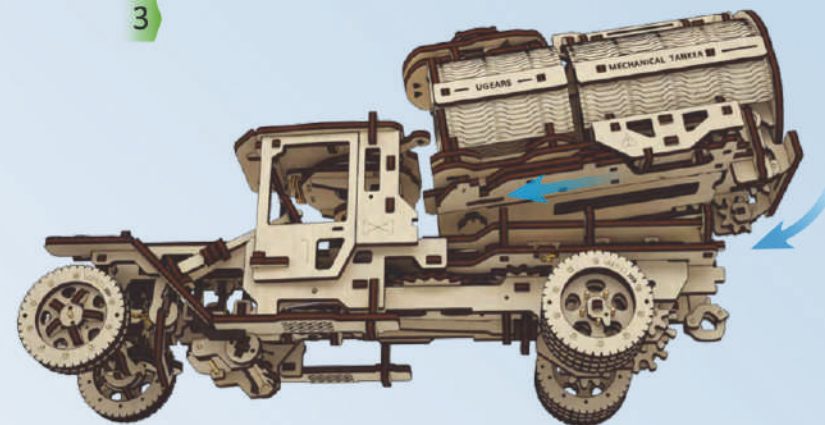

4

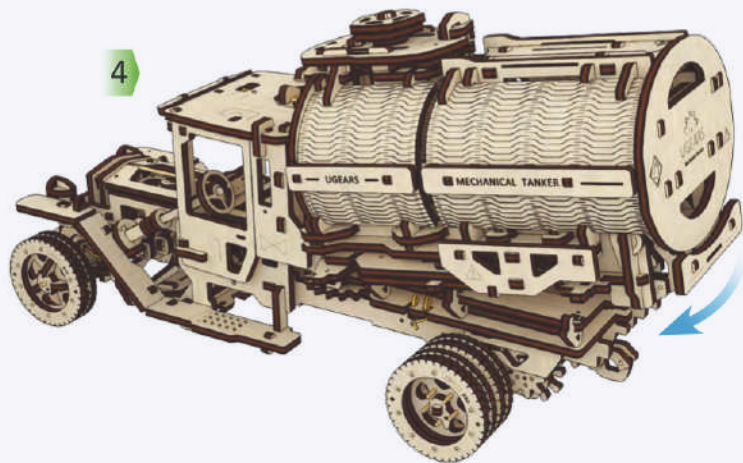

5

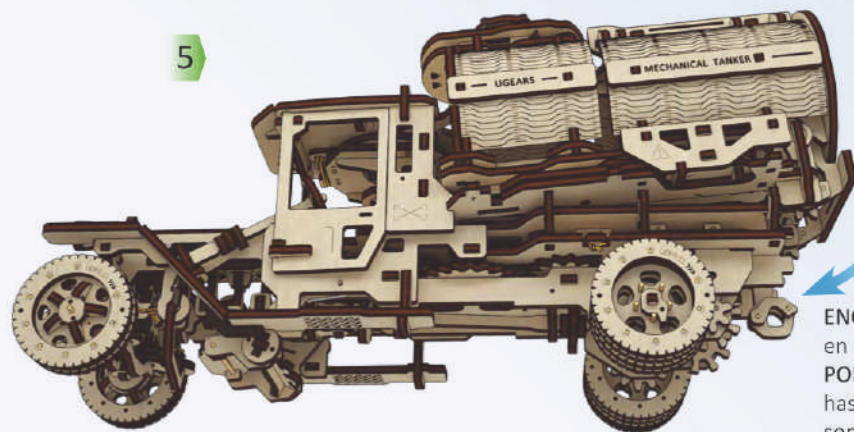

6

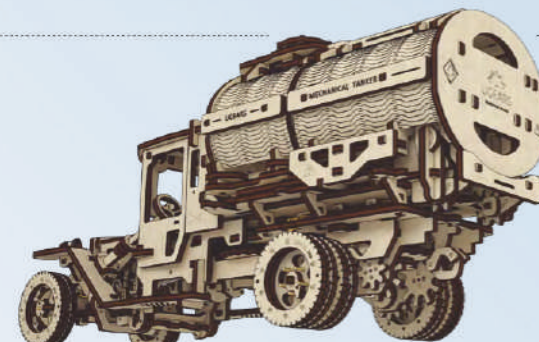

ENG Gress the piece all the way in. UKR Притисніть деталь до упору. DEU Drücken Sie das Bauteil bis zum Anschlag ein. FRA Appuyez sur la pièce jusqu'en butée. POL Delikatnie dociskać część aż do momentu pocucia oporu. SPA Presione la pieza hasta que haga tope. ITA Premere il componente aggiuntivo a fondo. TUR Parçayı sonuna kadar bastırın. RUS Прижмите деталь до упора. KOR 밀어 넣어 끼워 주세요. CHI 把罐压住到底。

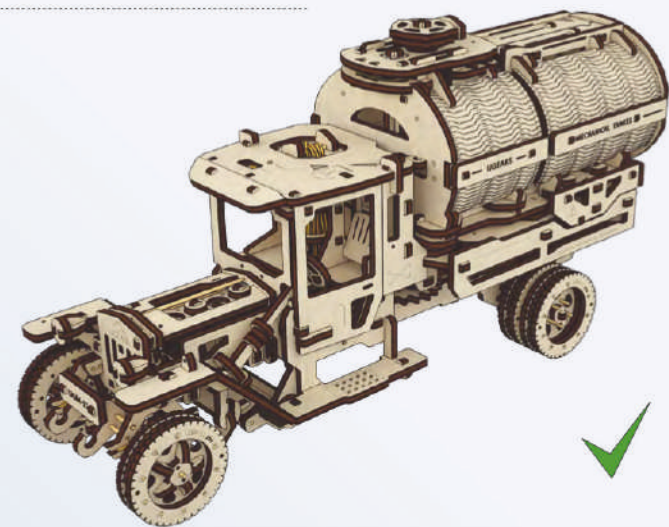
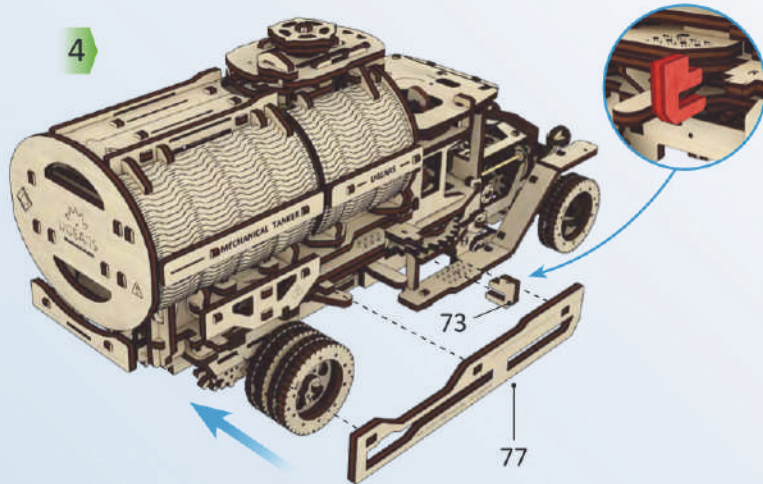
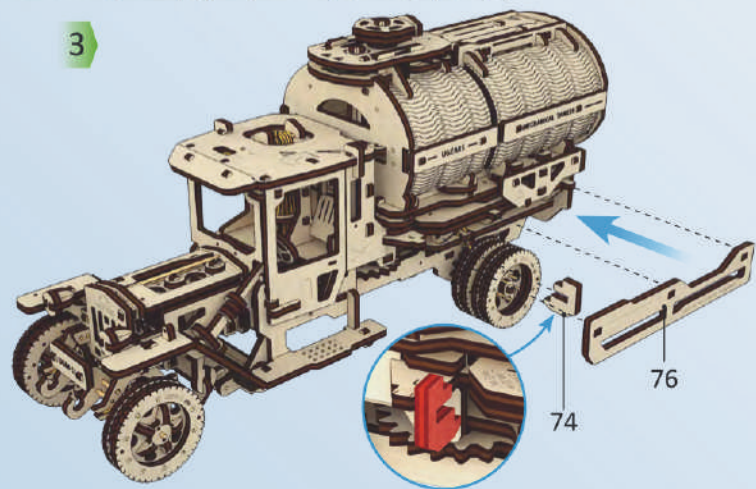
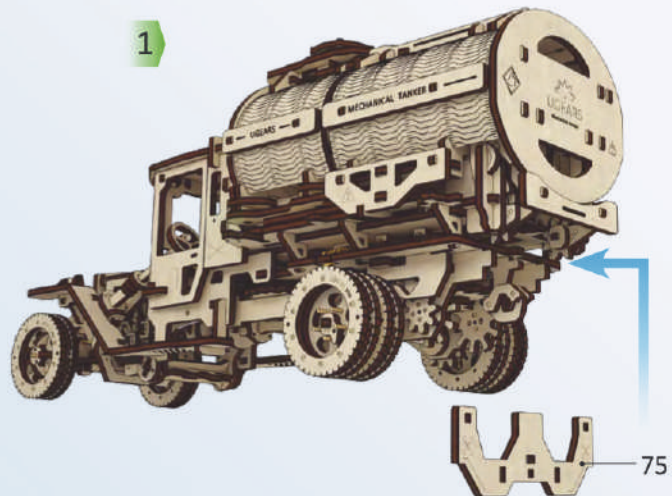
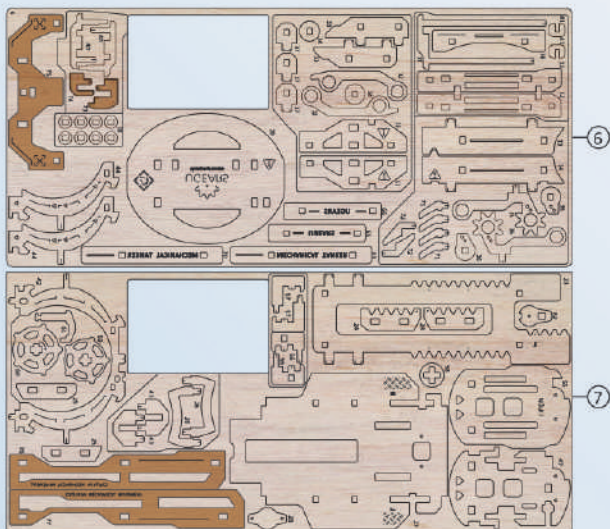



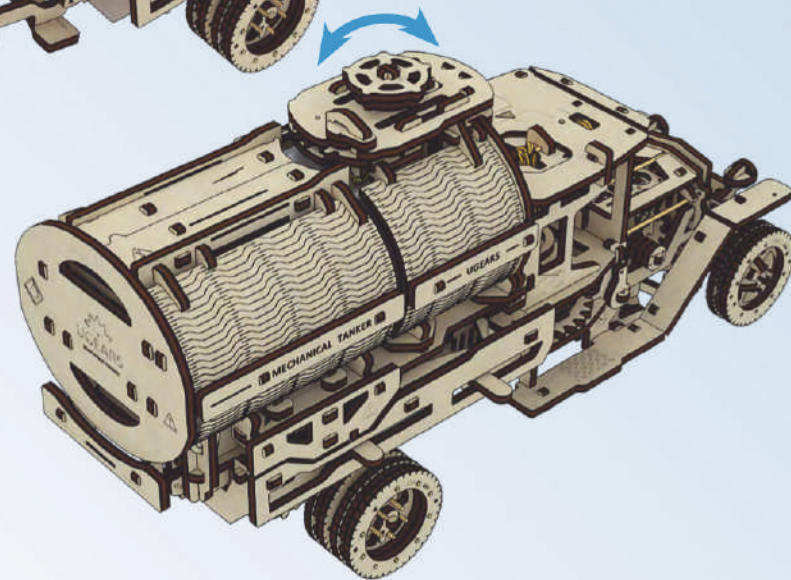
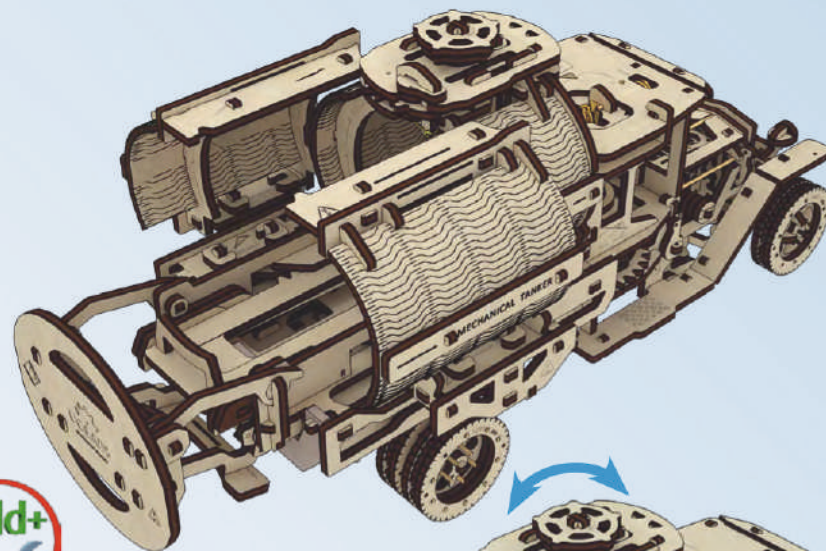
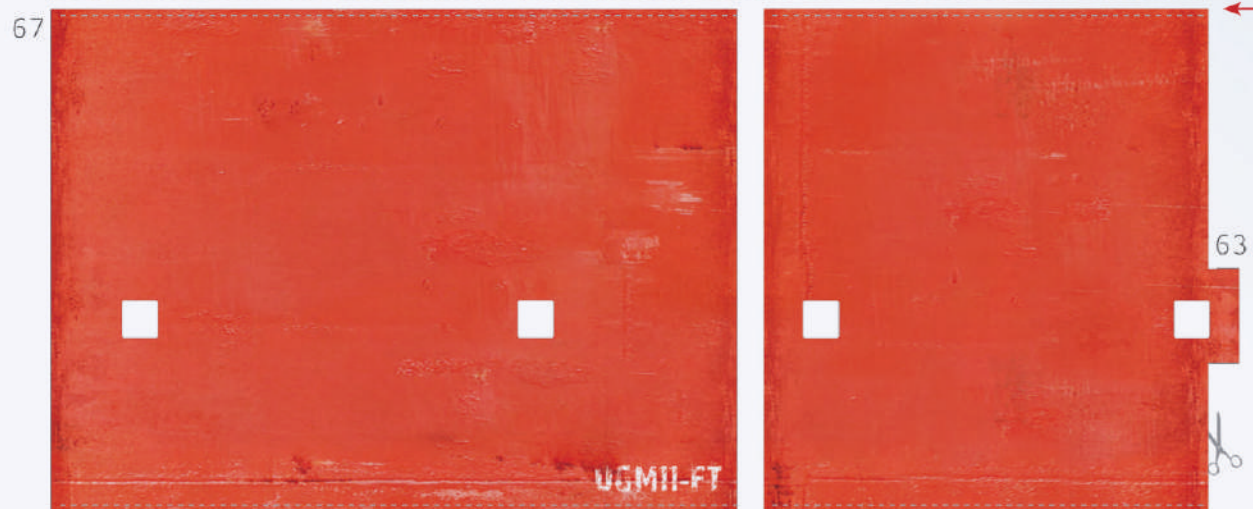
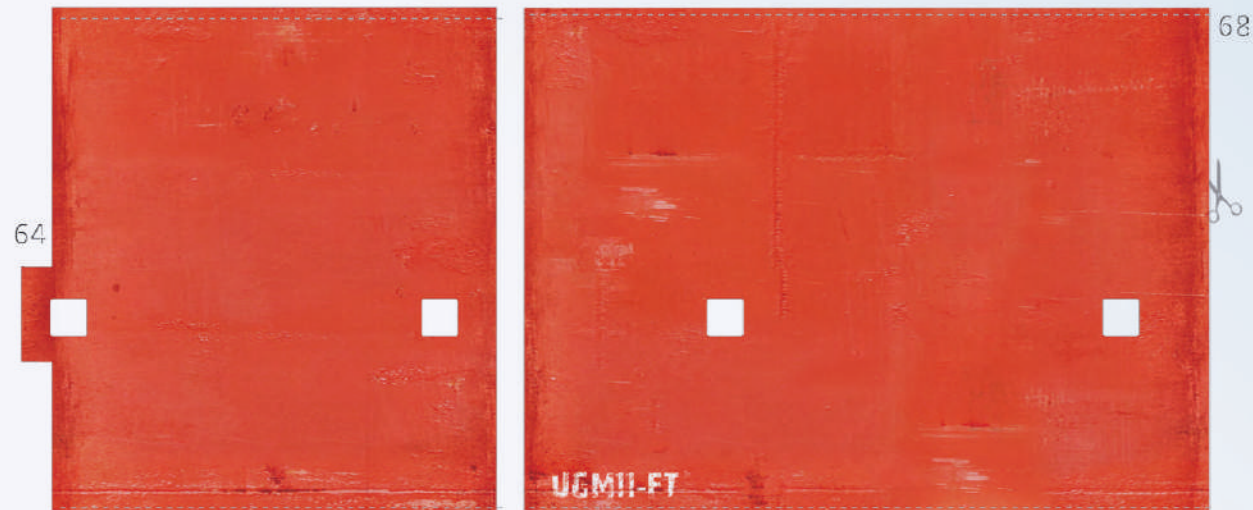

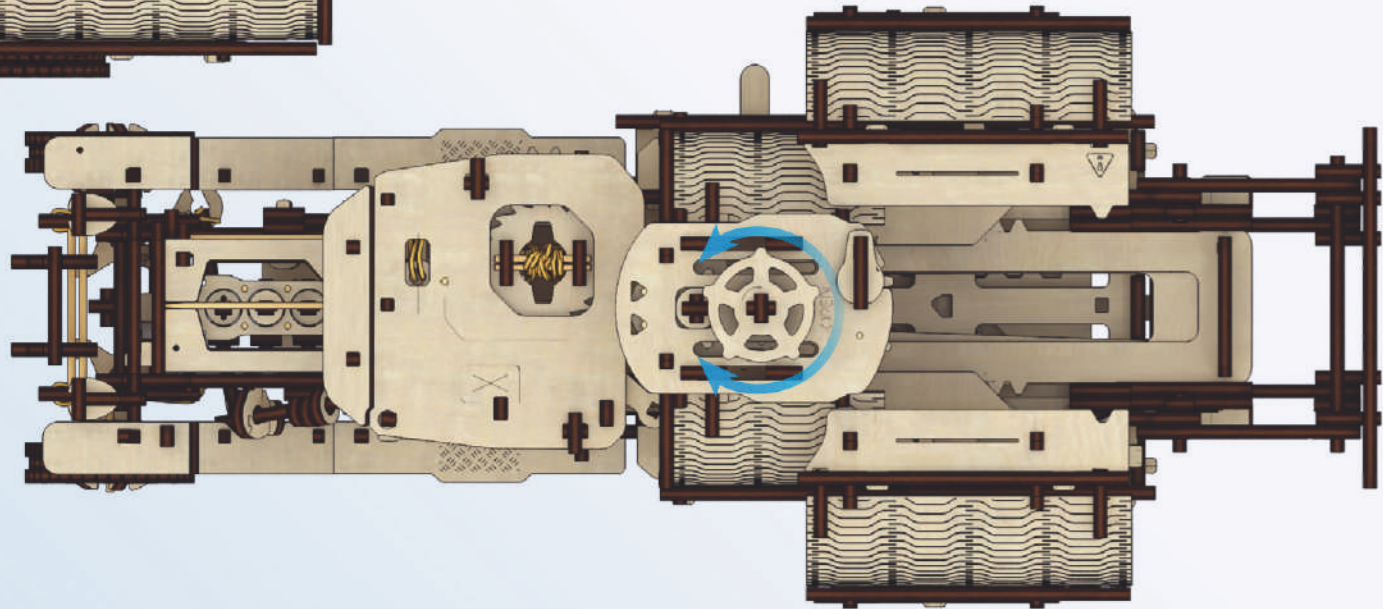
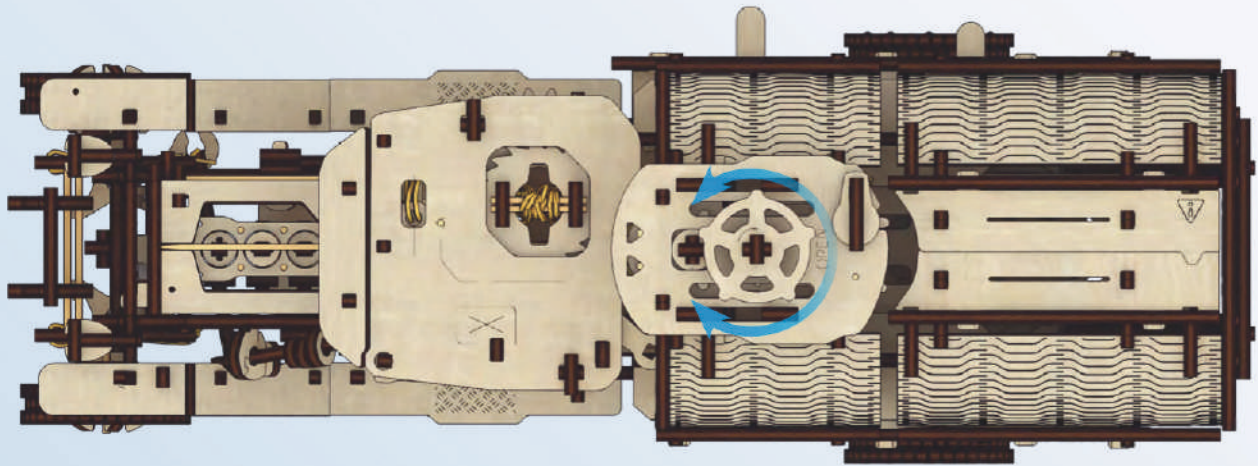

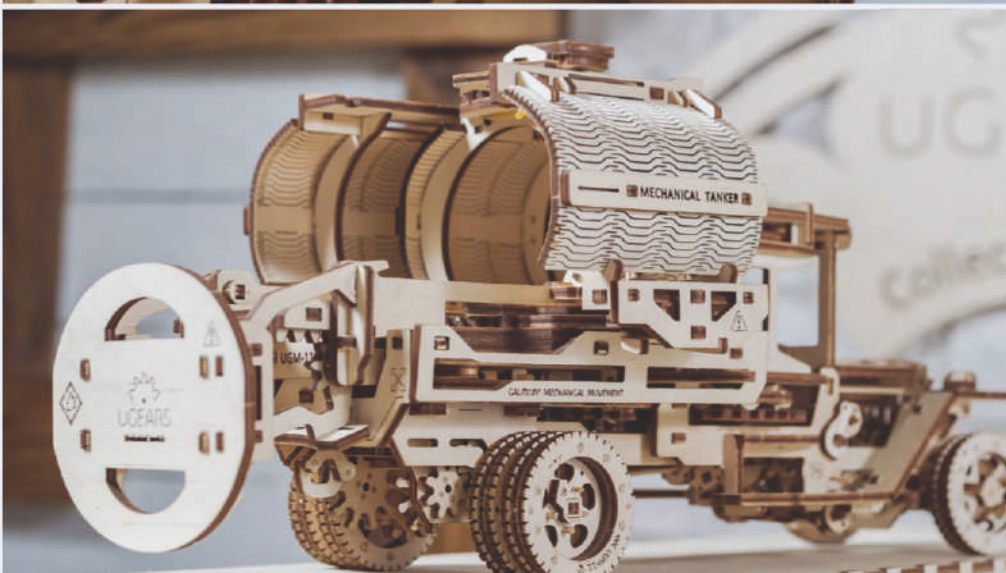
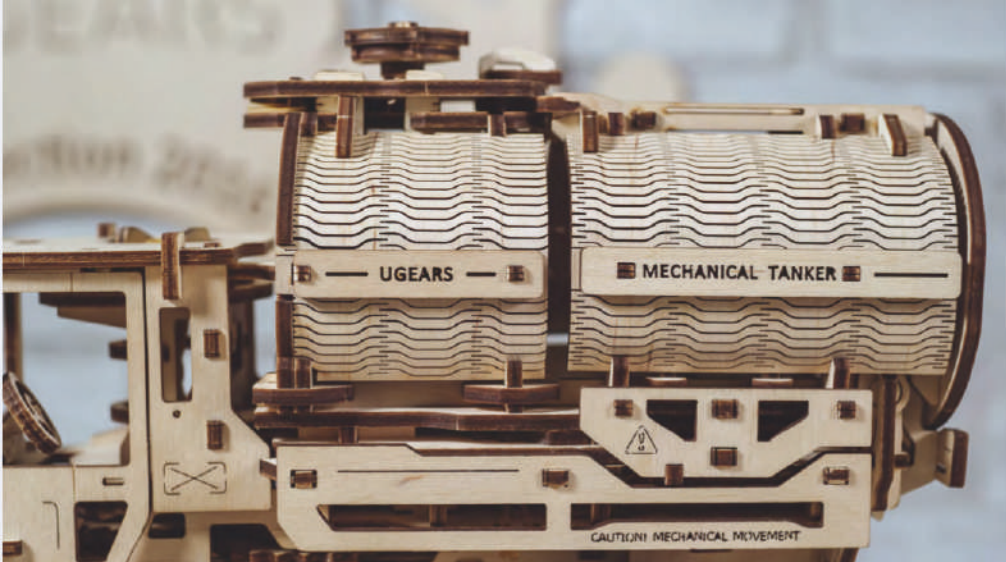

UKR Пожежна драбина. ENG Ladder. DEU Drehleiter.  
FRA Echelle. POL Drabina. SPA La escalera. ITA Scala. TUR Merdiven  
RUS Пожарная лестница. KOR 사다리차. CHI 消防梯

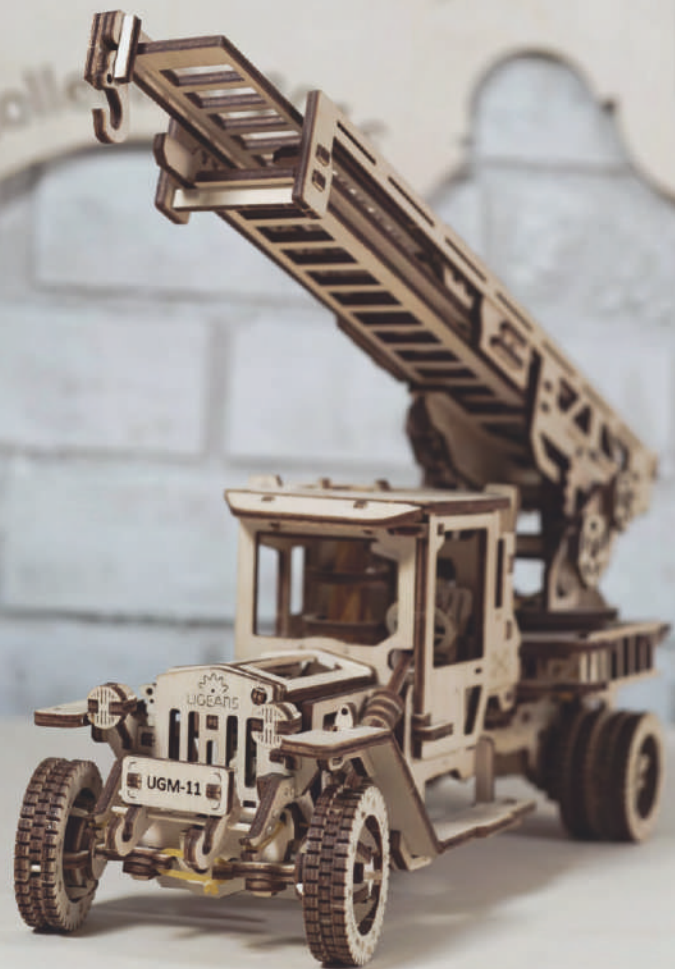

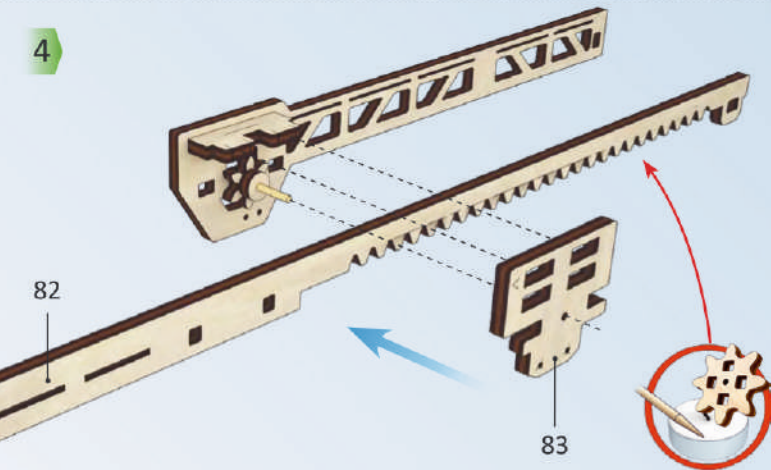
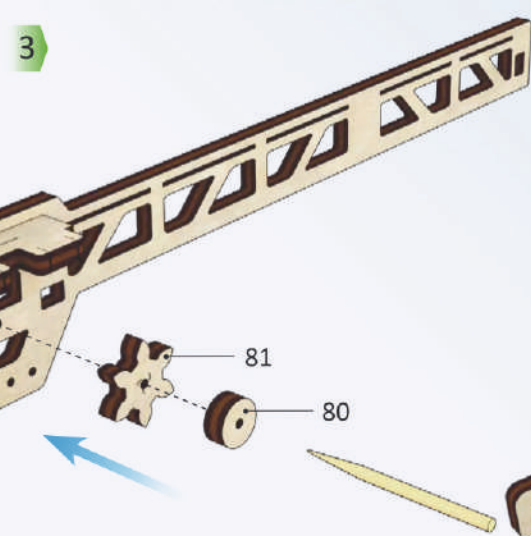
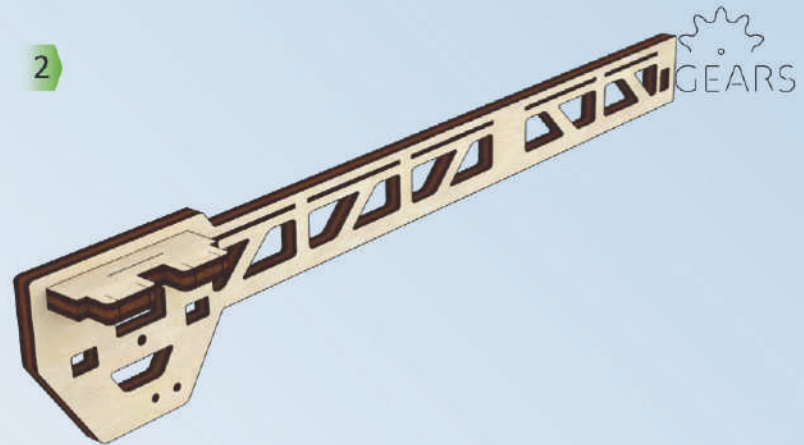
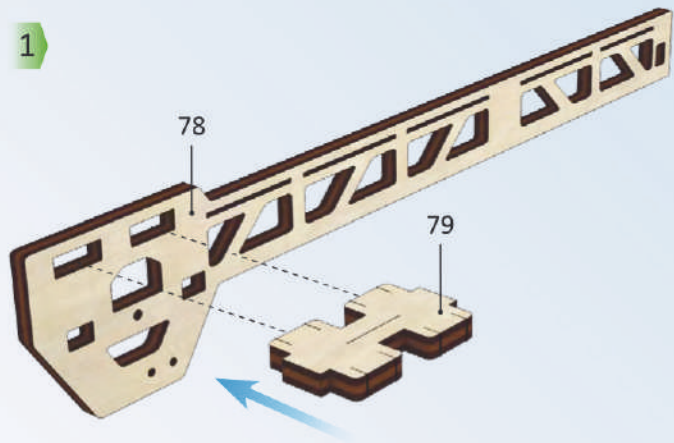
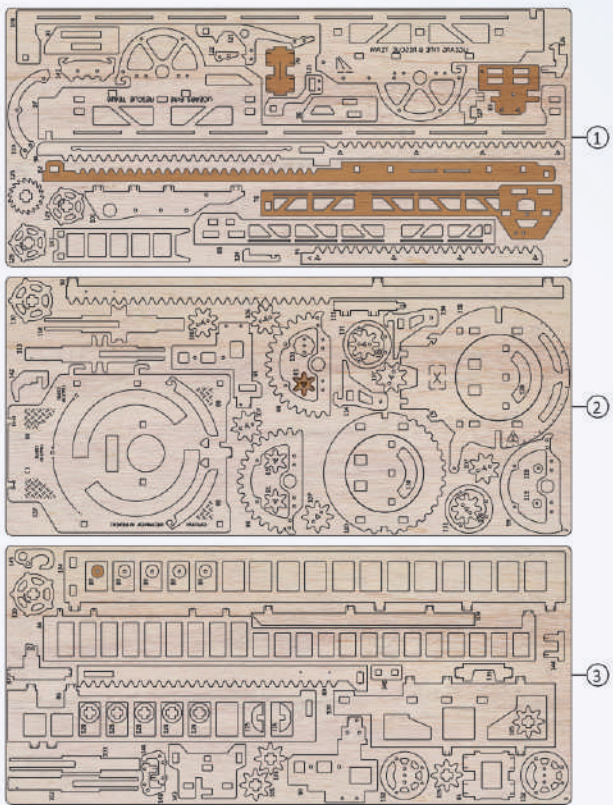

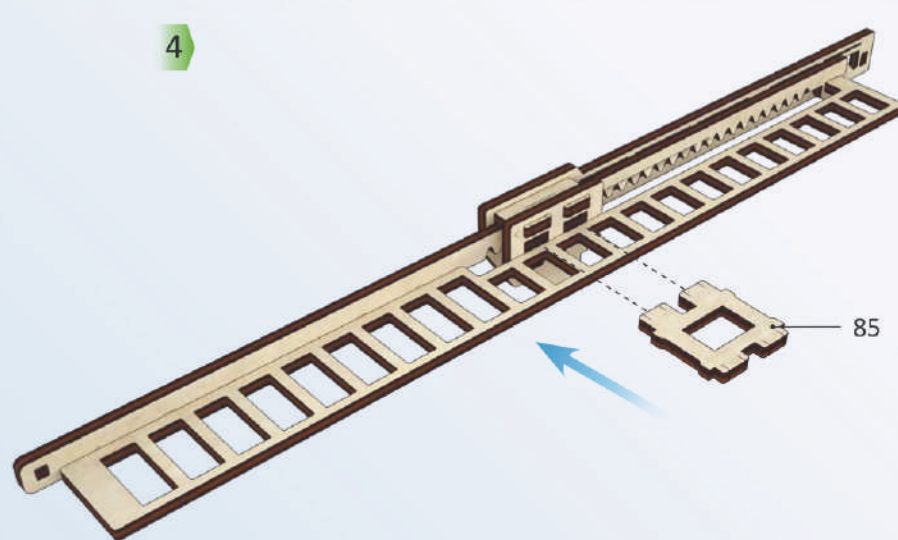
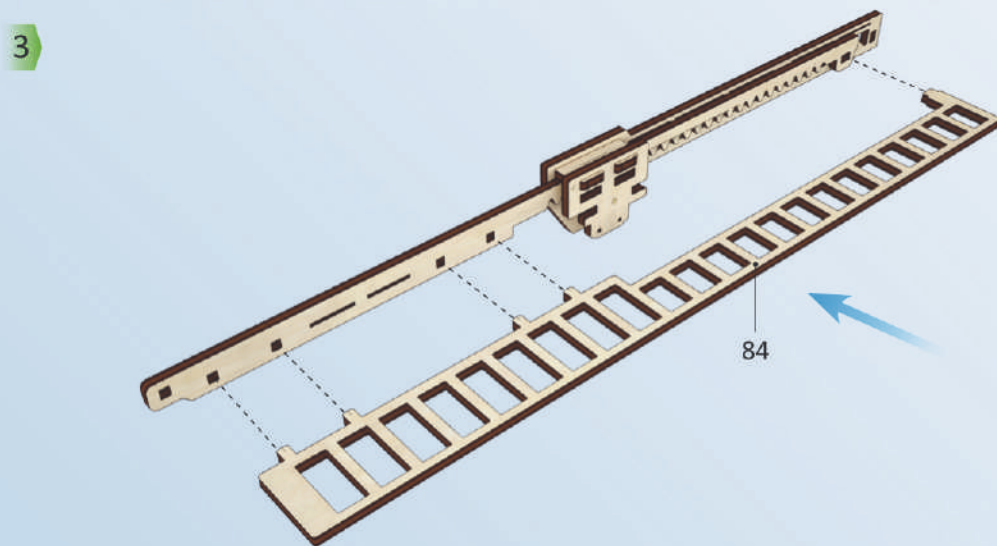
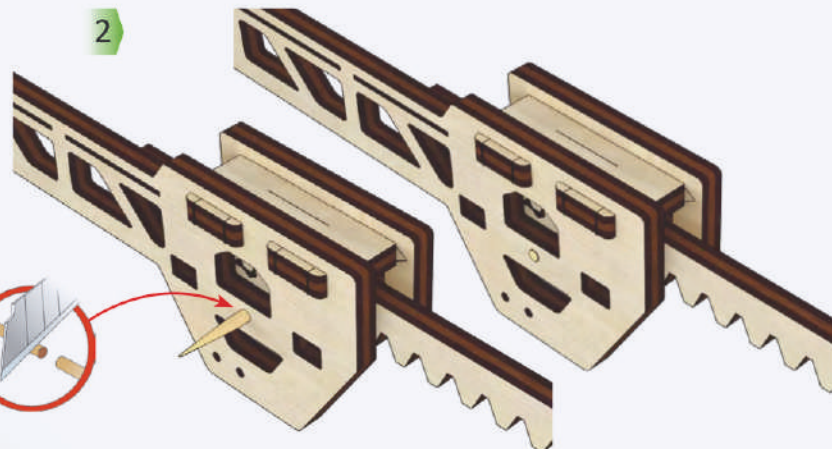
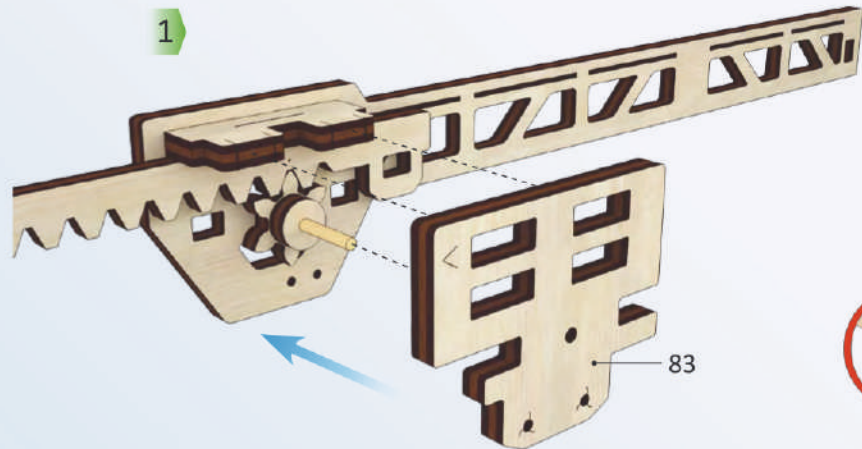
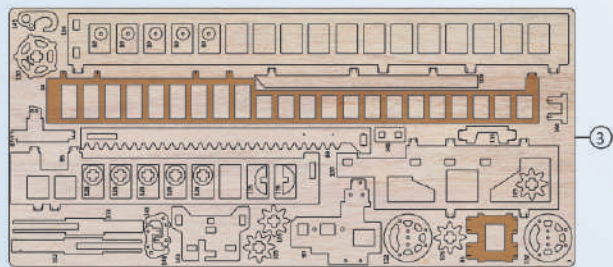

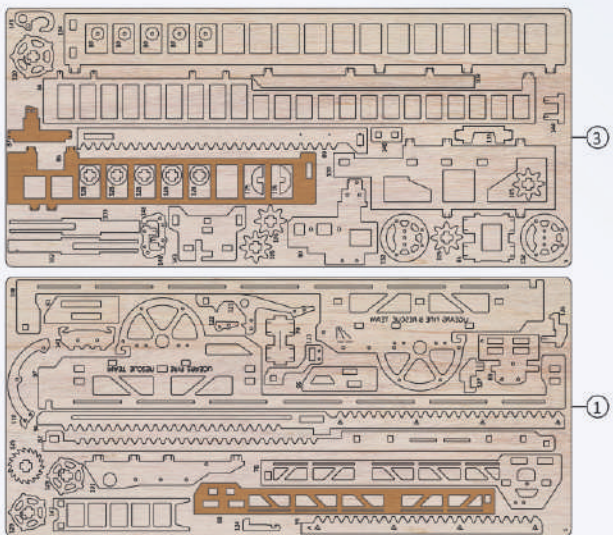

1

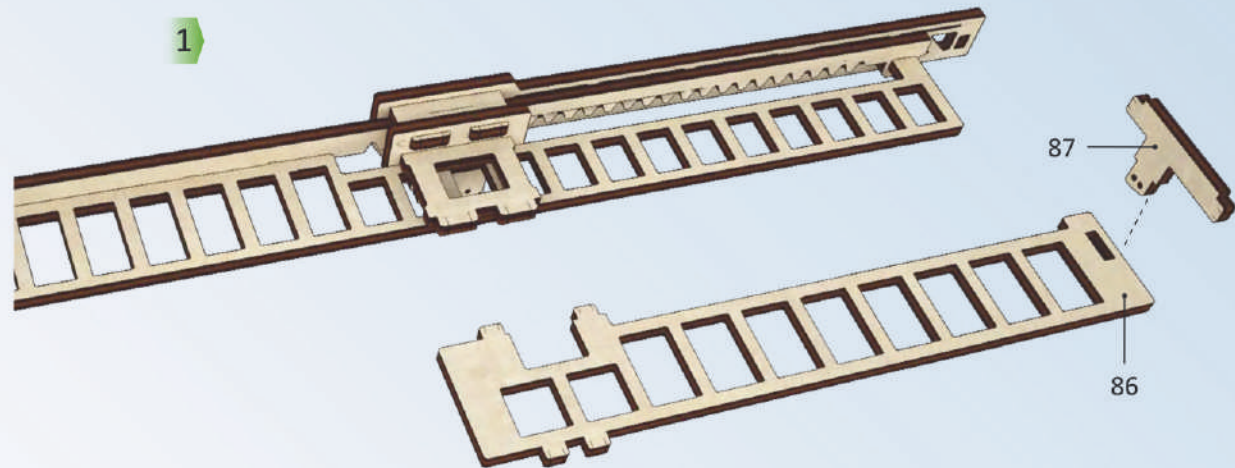

2

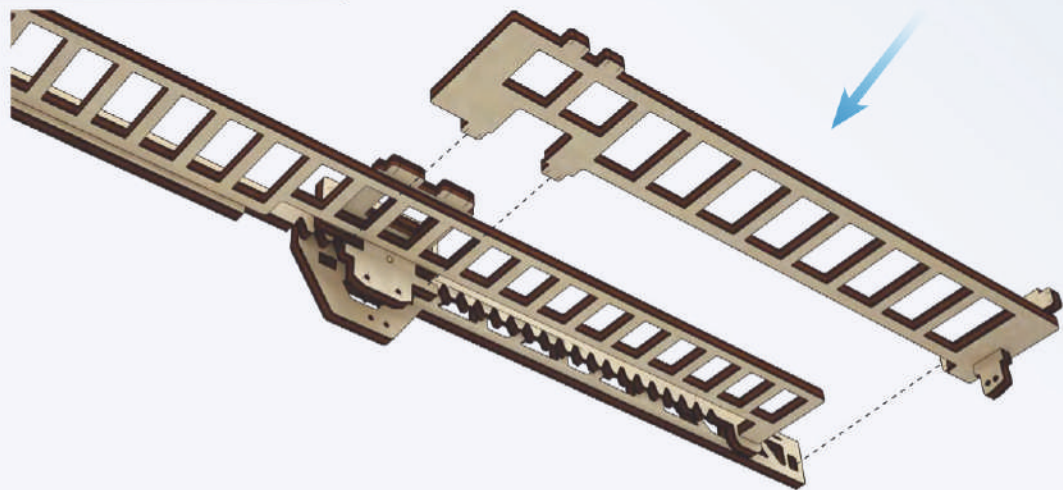

3

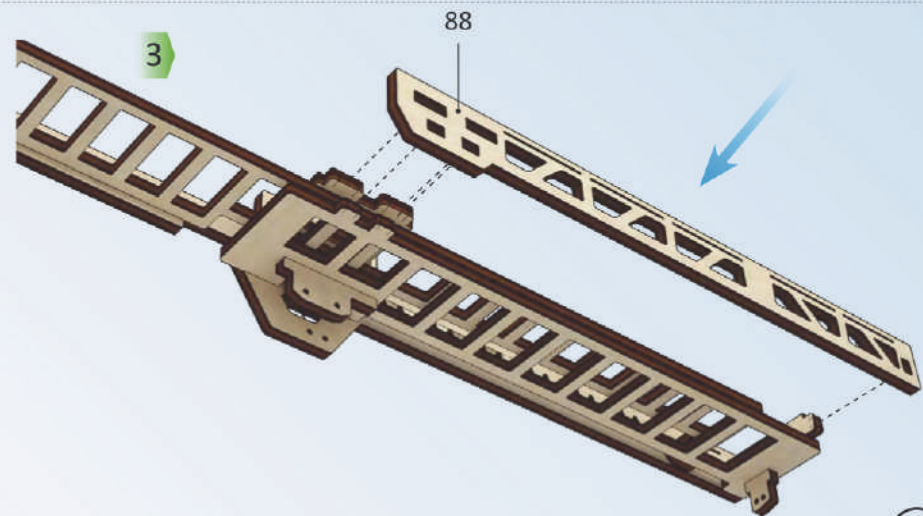

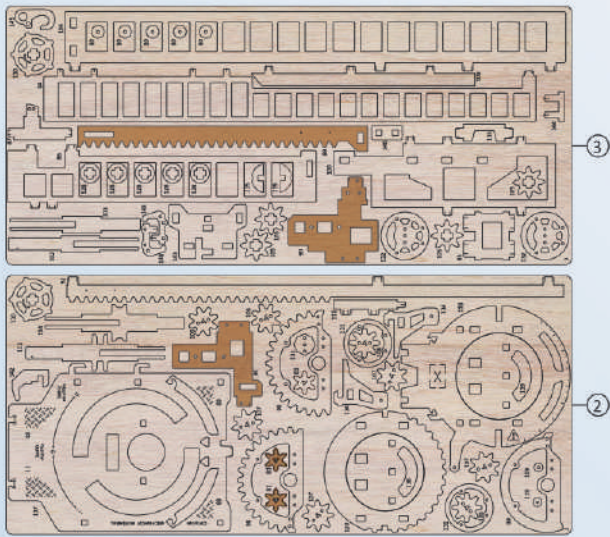

1

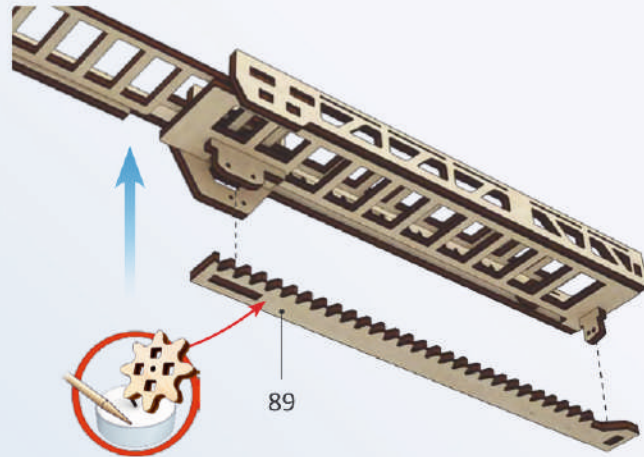

2

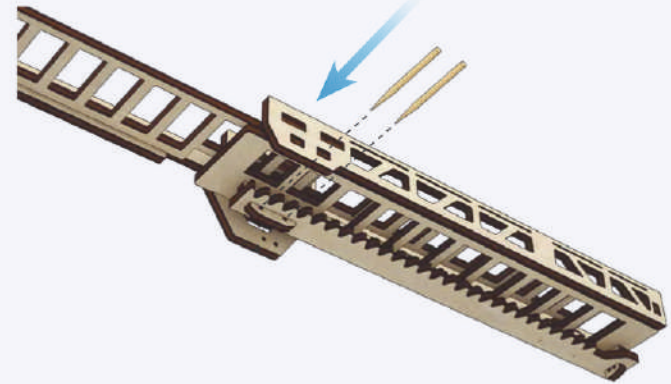

3

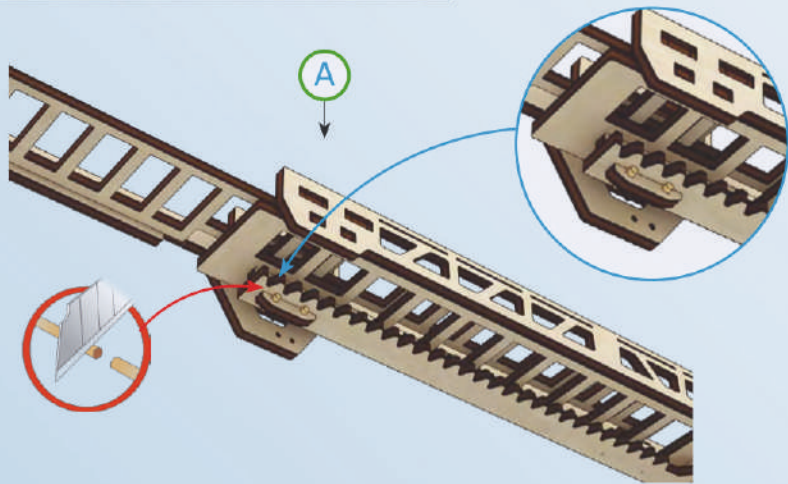

3

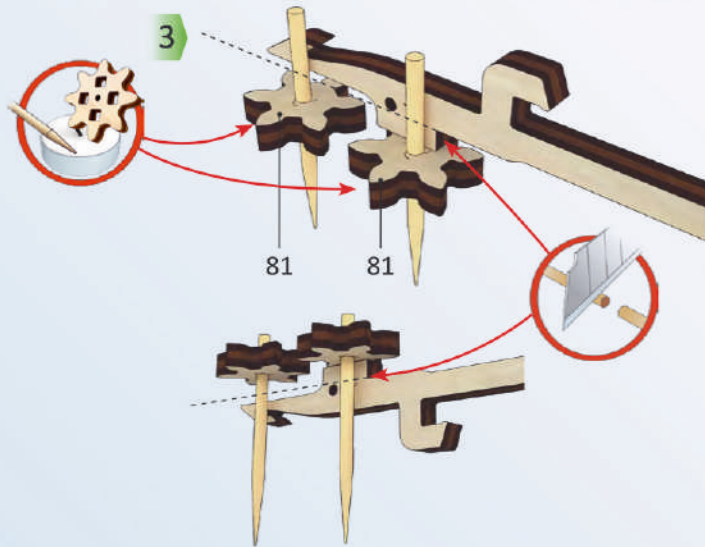

91

90



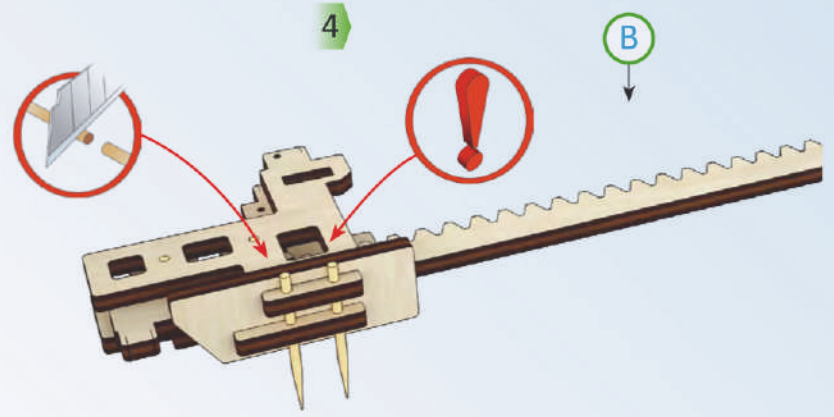
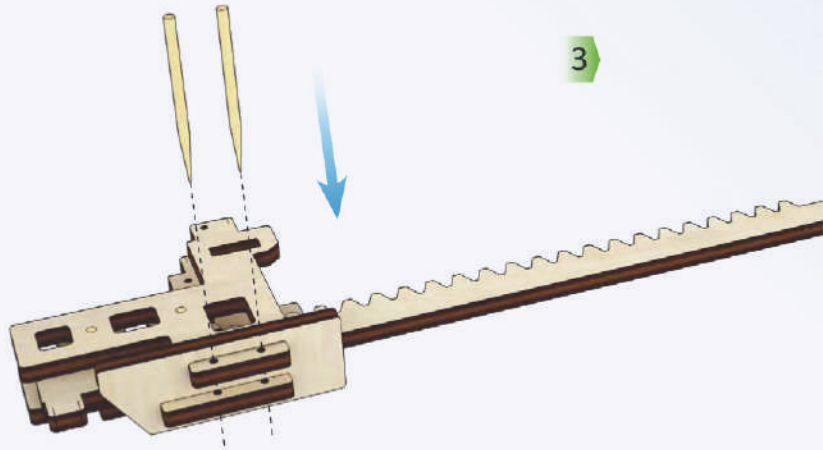
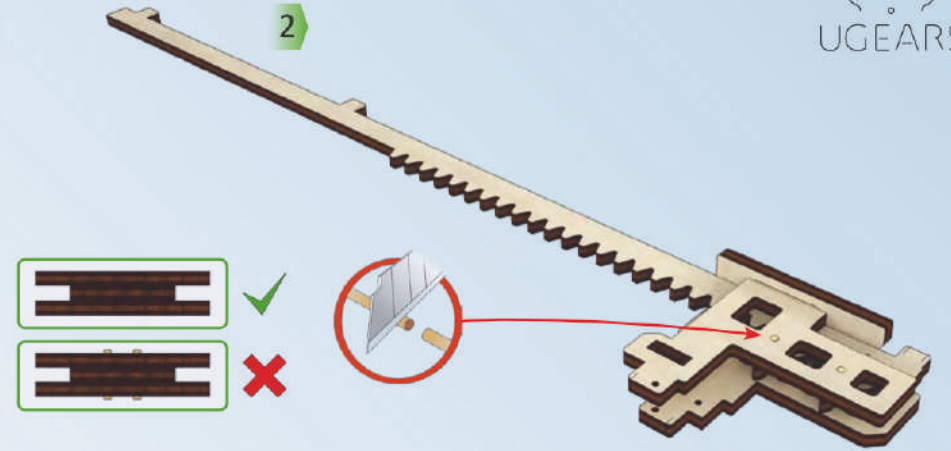
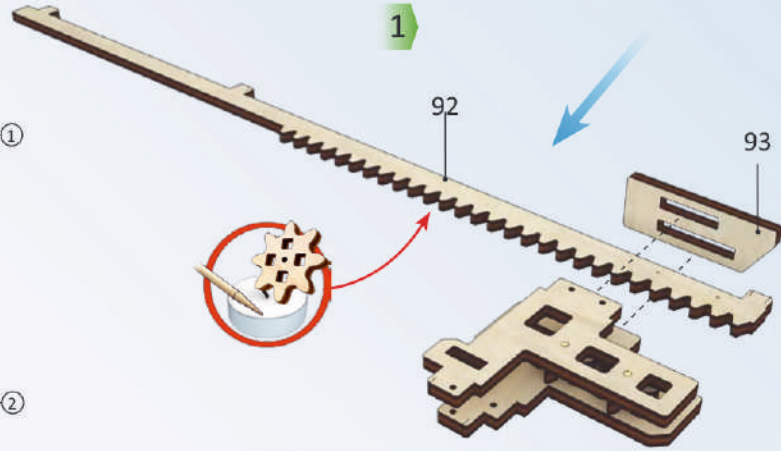
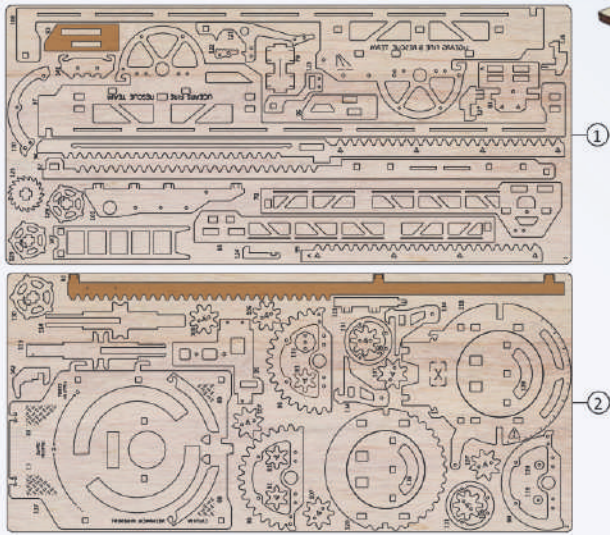

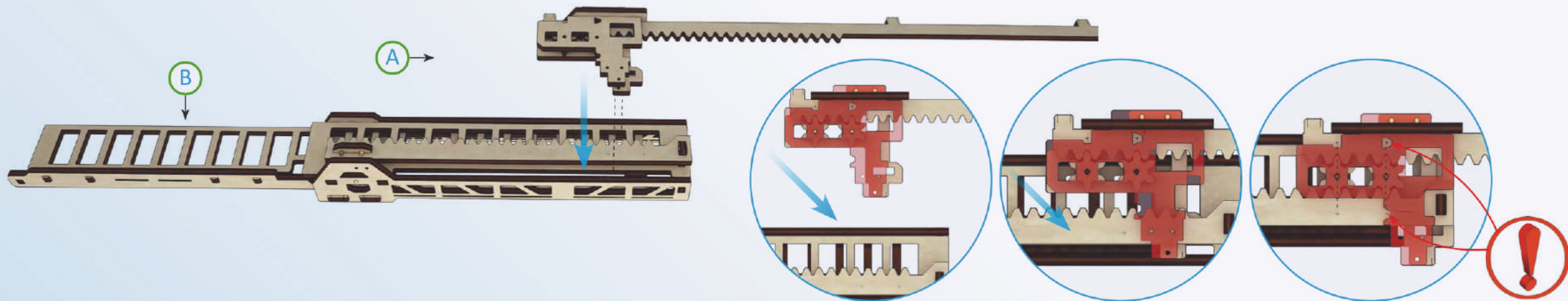

ENG Put the marks together. UKR Поєднайте мітки. DEU Führen Sie die Markierungen zusammen. FRA Alignez les marques. POL Złóżyc znaki. SPA Juntará los las marcas. ITA Unire ed assemblare gli incastri. TUR İşaretleri birleştirin. RUS Совместите метки. KOR 표시를 맞춰주세요. CHI 重合标志

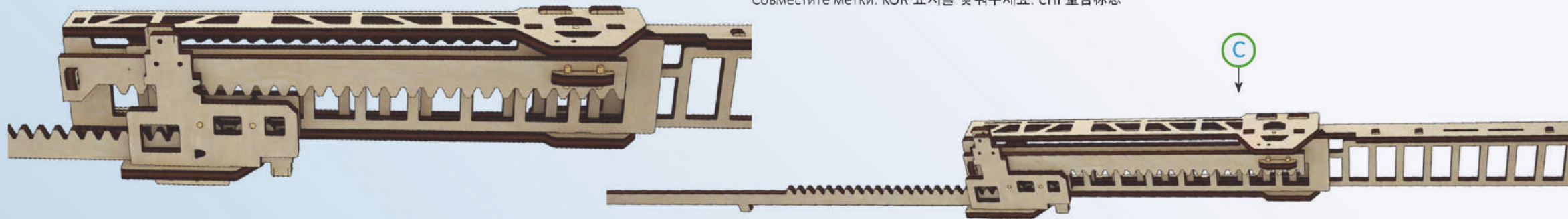

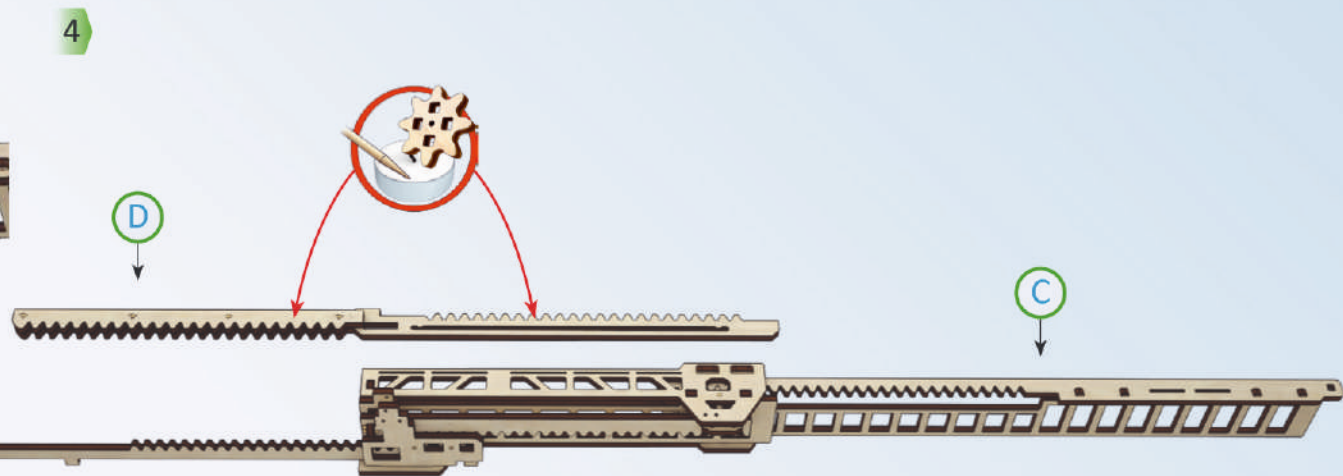
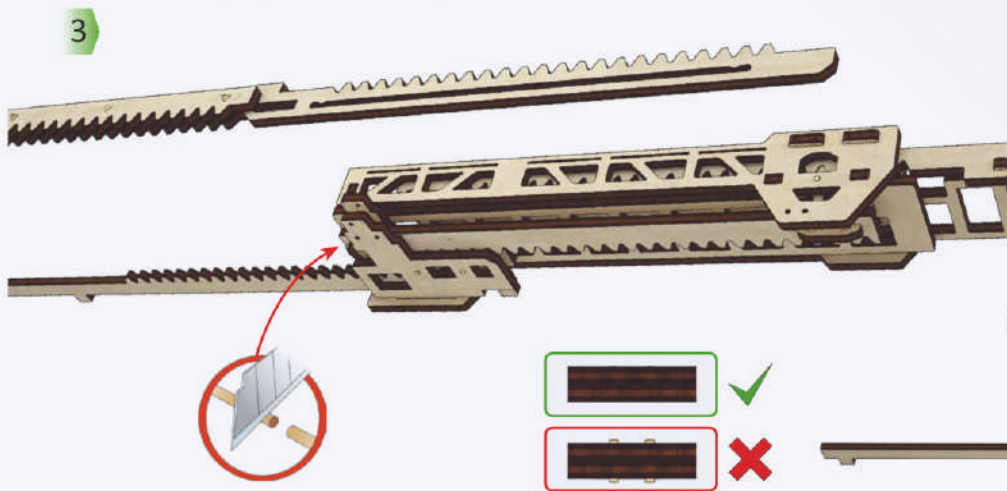
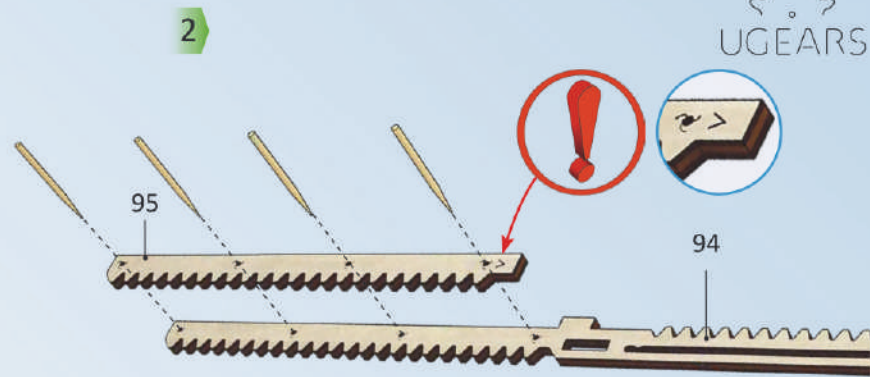
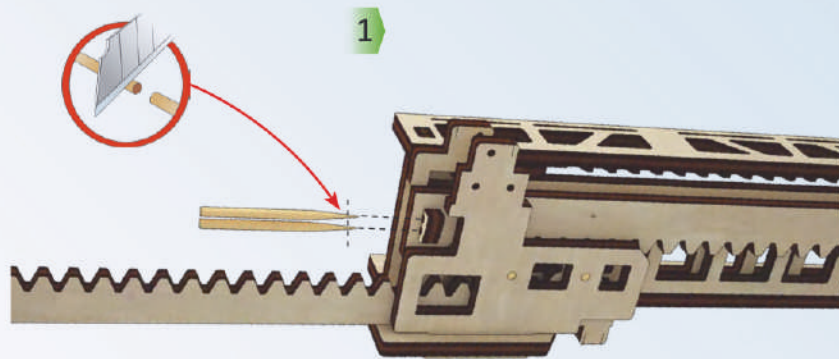
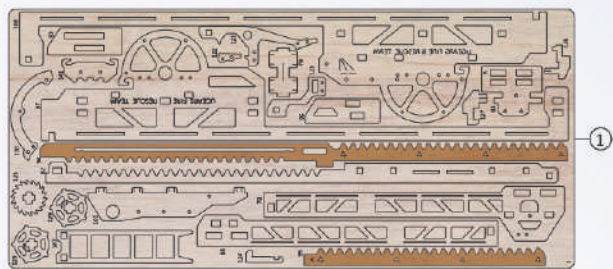

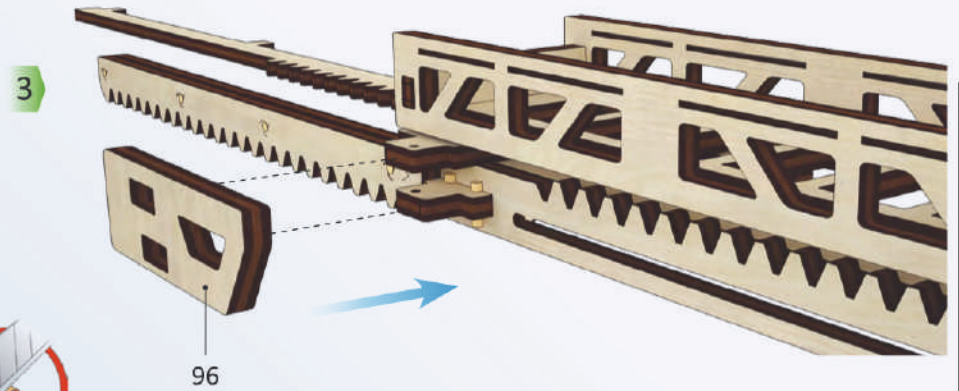
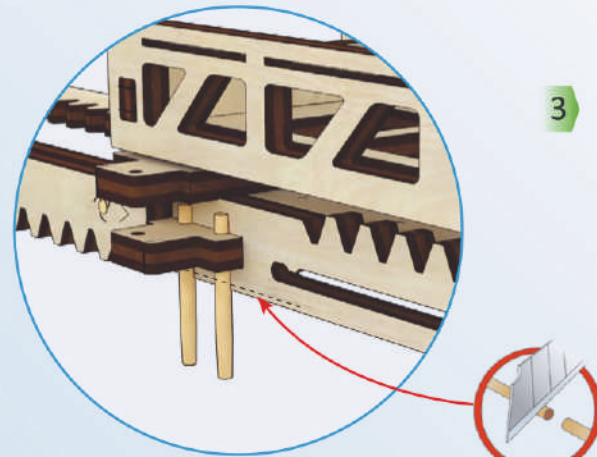
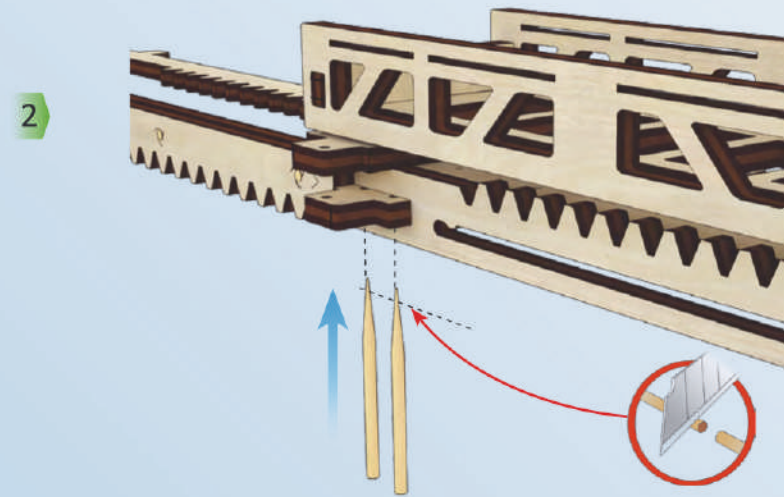
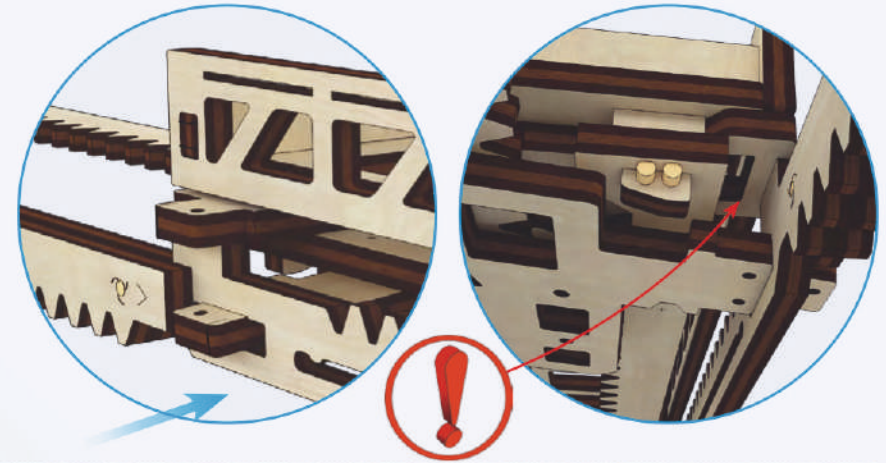
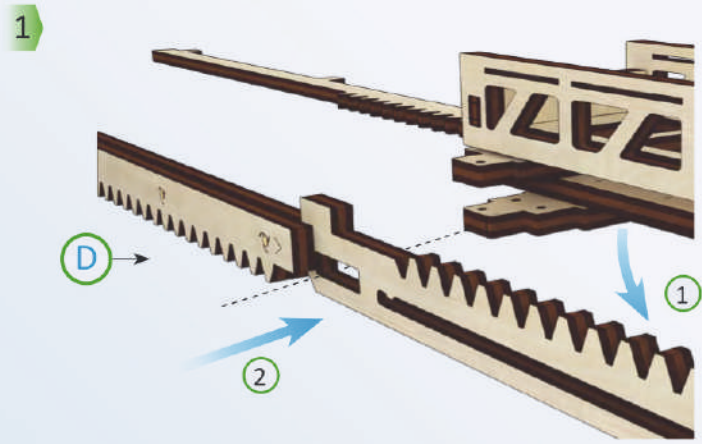
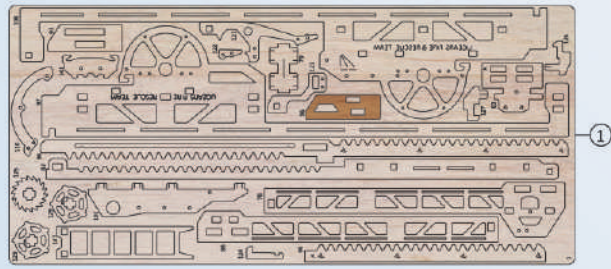

1

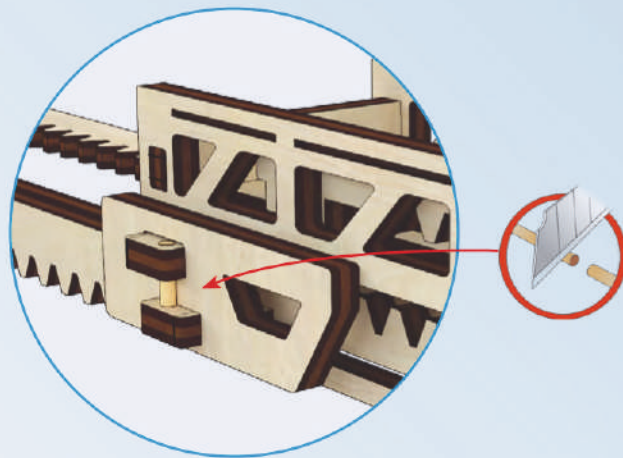
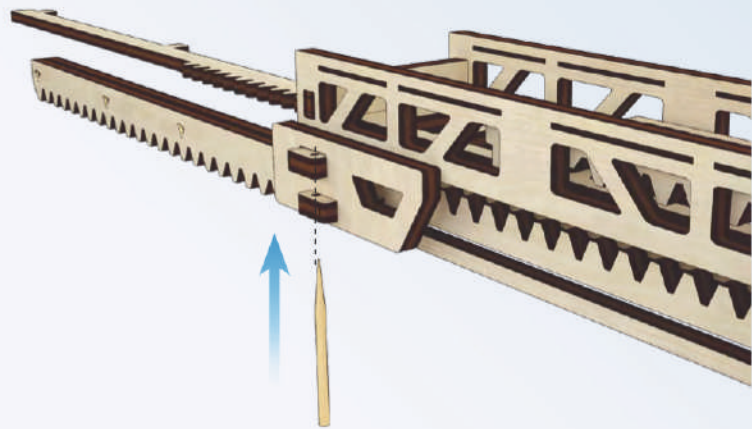

2

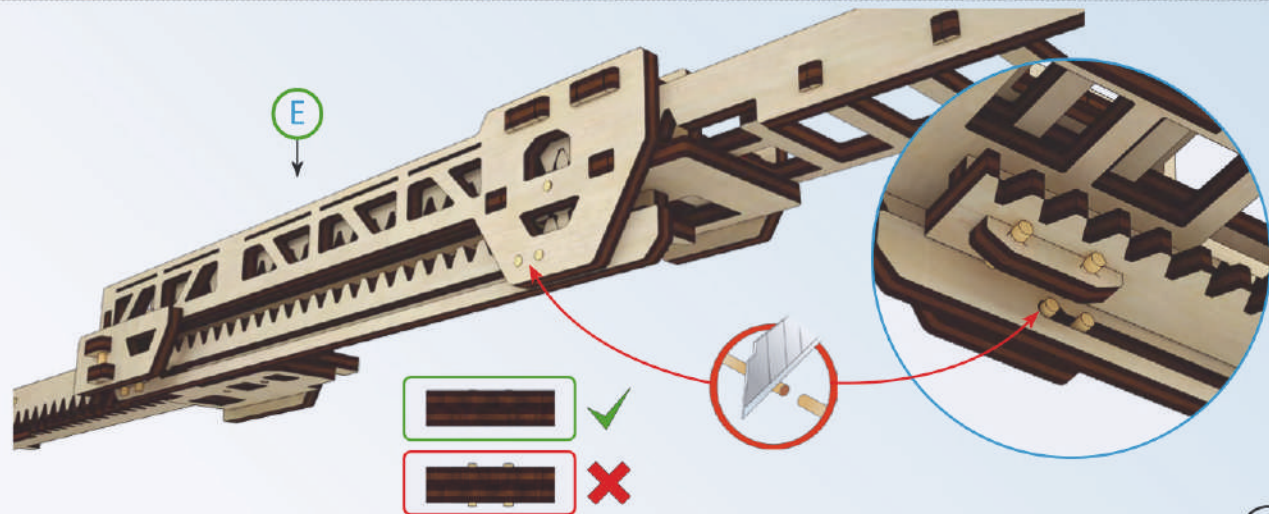
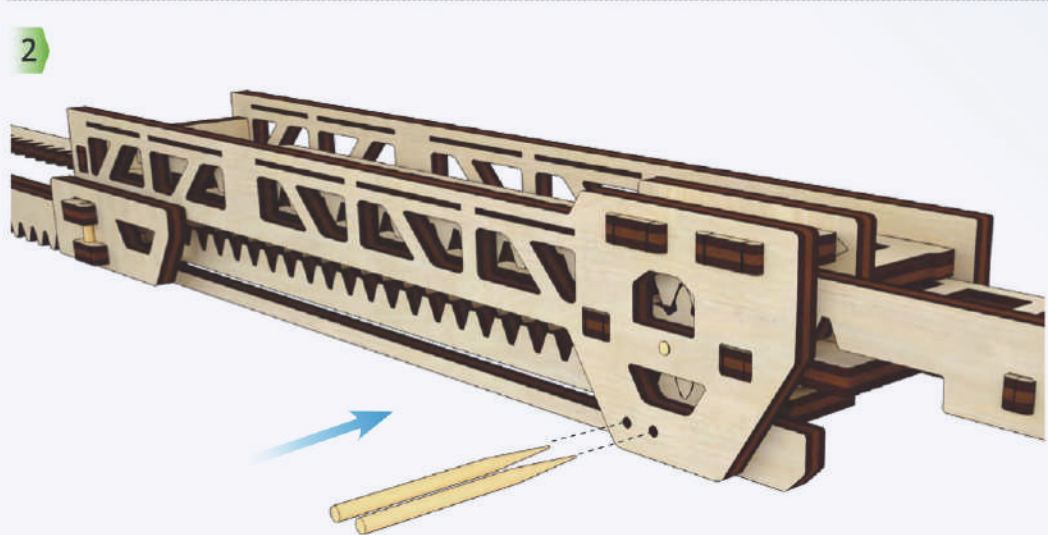

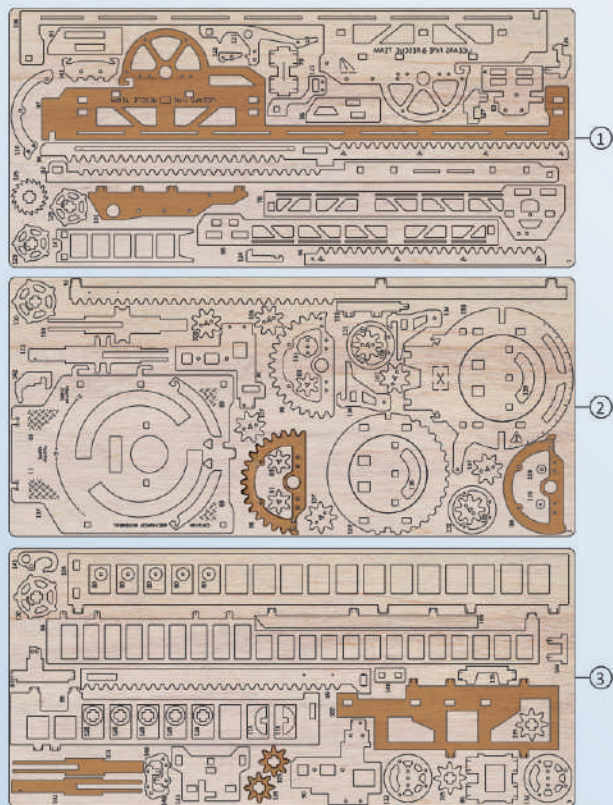

ENG Left side. UKR Ліва сторона. DEU Linke Seite. FRA Côté gauche. POL Lewa strona. SPA El lado izquierdo. ITA Parte sinistra. TUR Sol taraf. RUS Левая сторона. KOR 좌측면. CHI 左侧

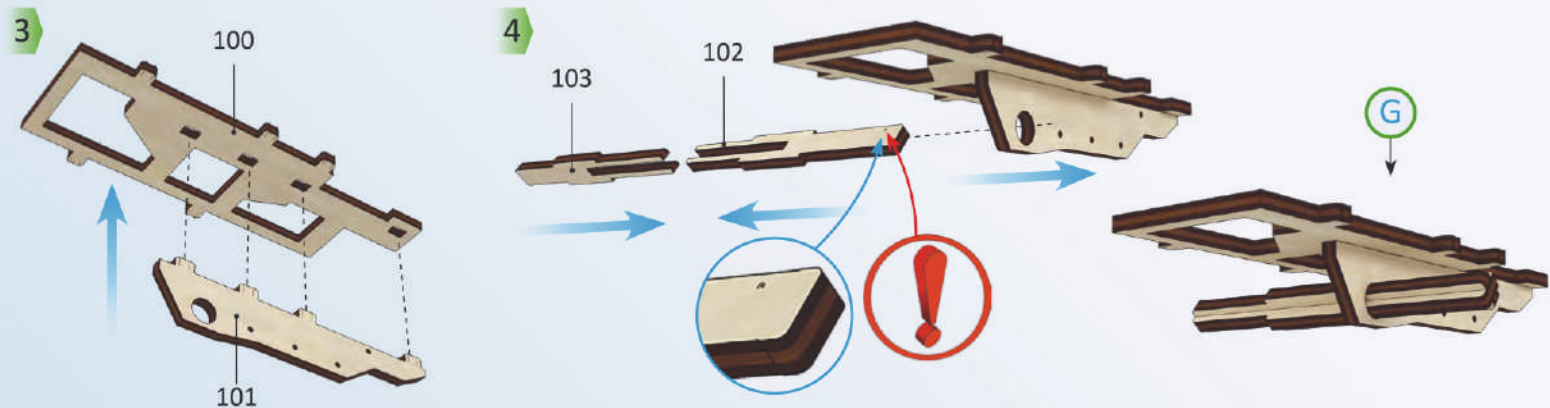
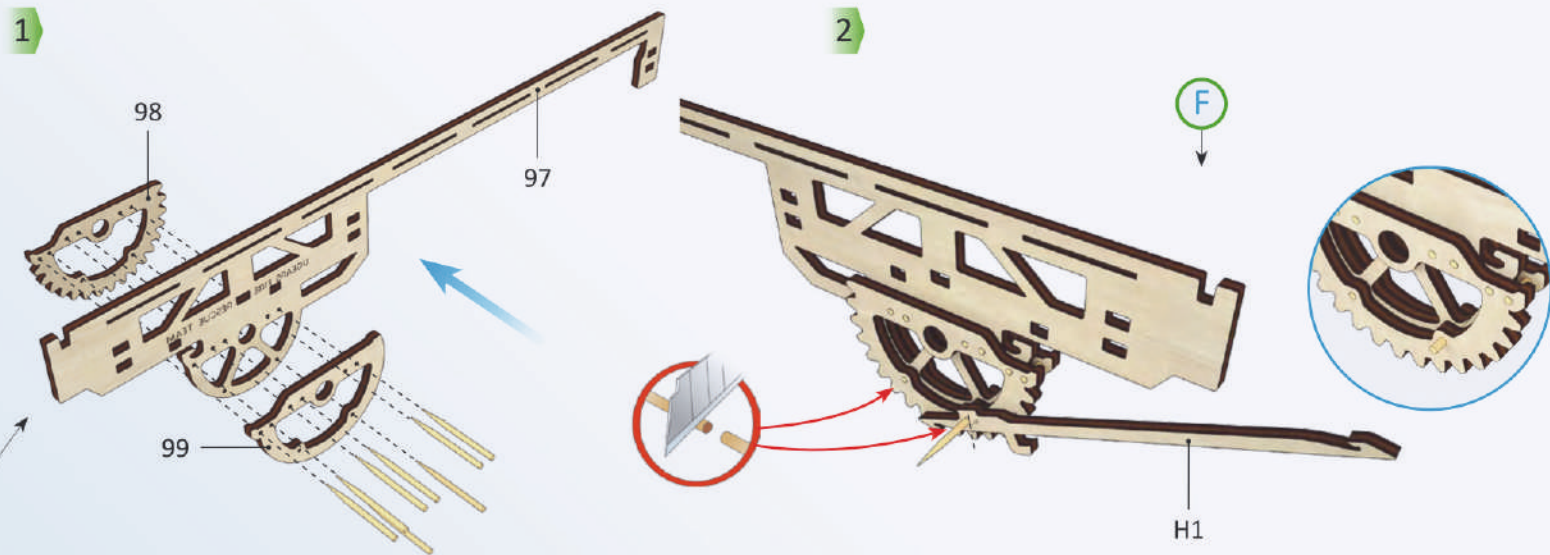

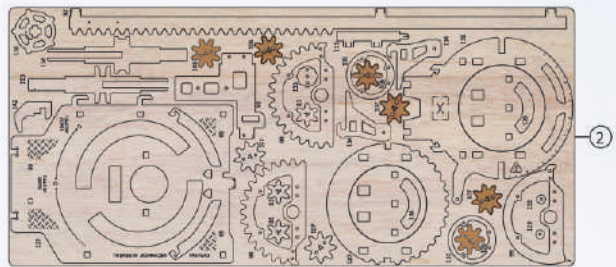

2

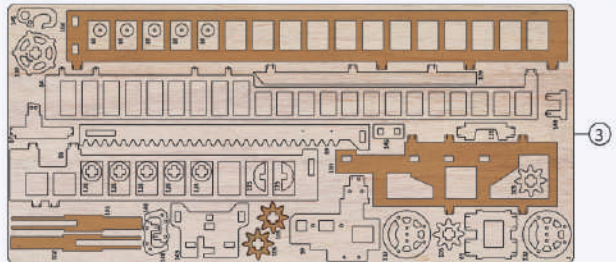

3

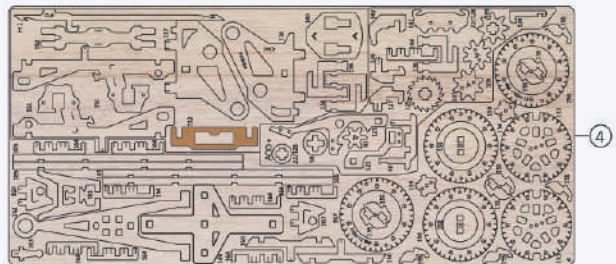

4

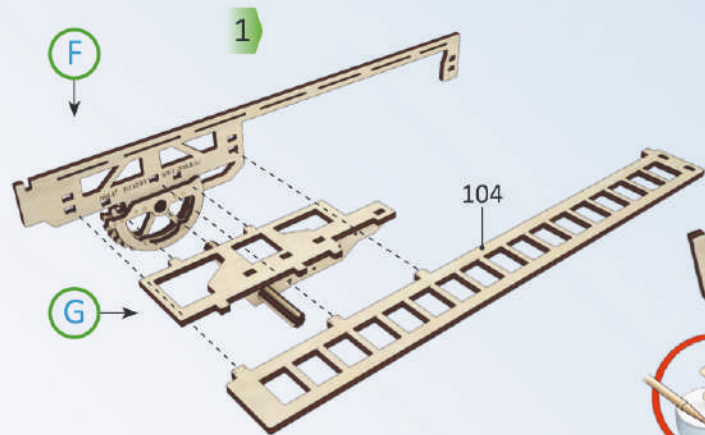

F

1

G

104



2

105

105

H

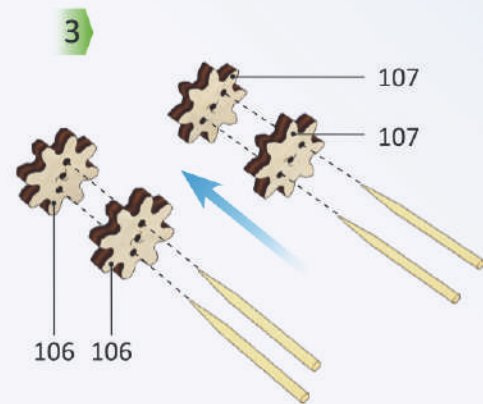

3

107

107

106

106

x2

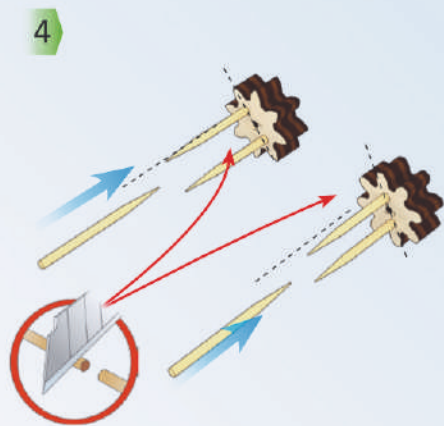

4

J1

J2

H1



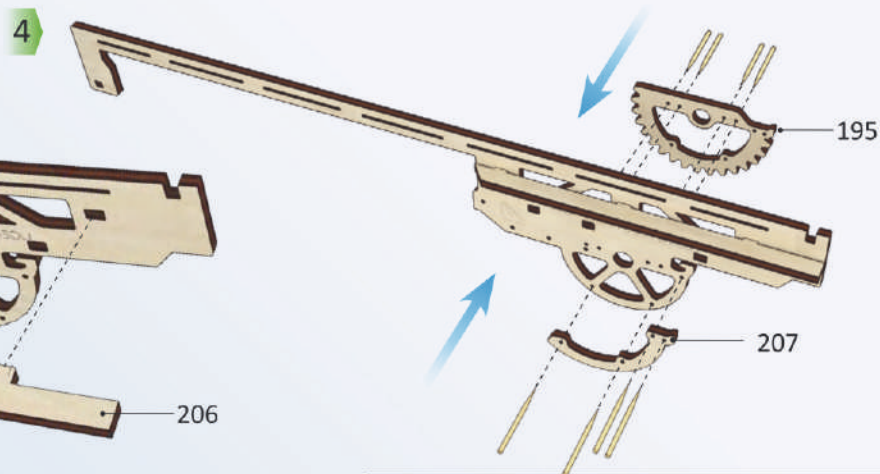
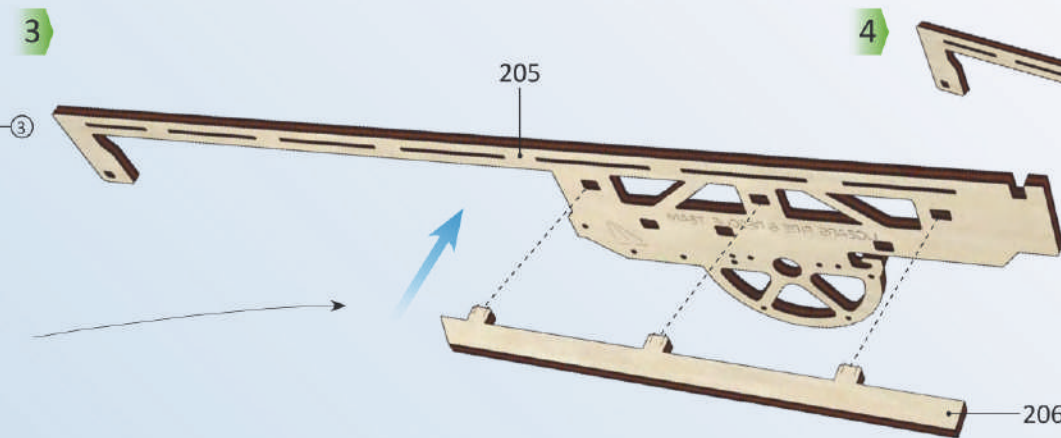
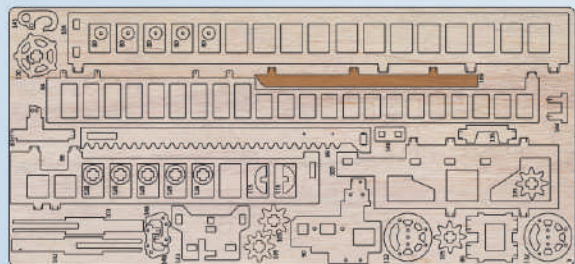
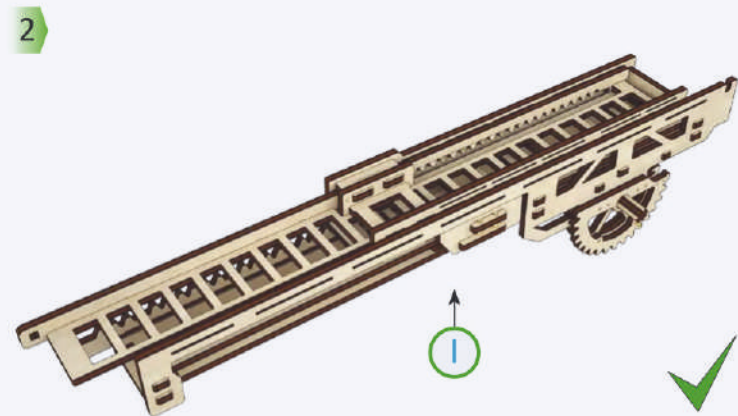
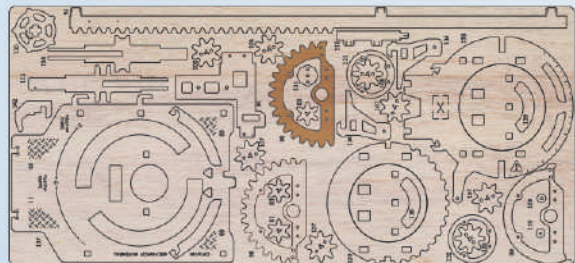
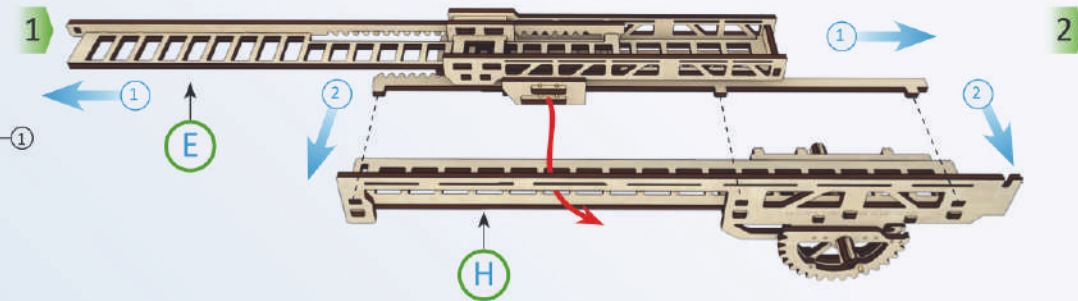
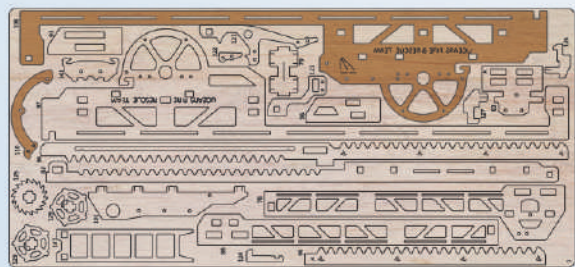

UKR Права сторона. ENG Right side. DEU Rechte Seite. FRA Côté droit. POL Prawa strona. SPA El lado derecho. ITA Parte destra. TUR Sağ taraf. RUS Правая сторона. CHI 右侧



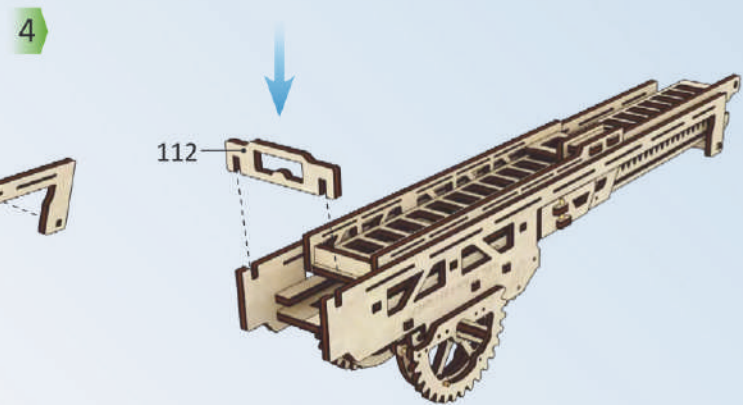
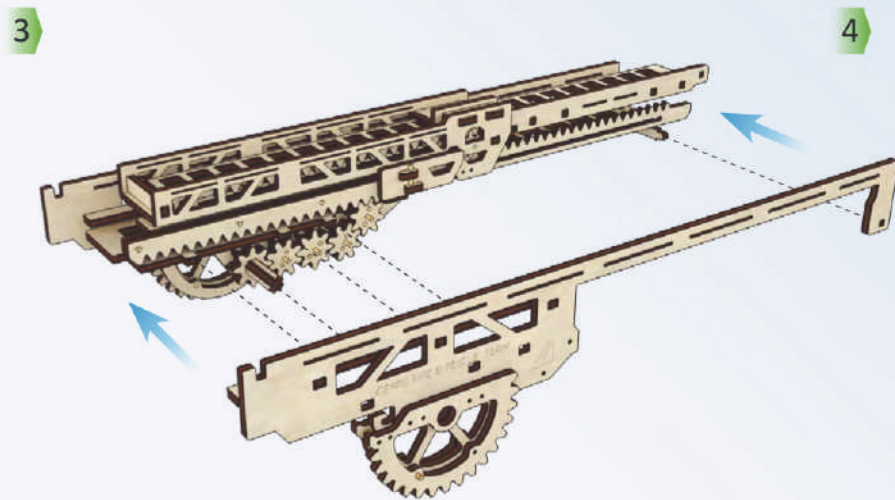
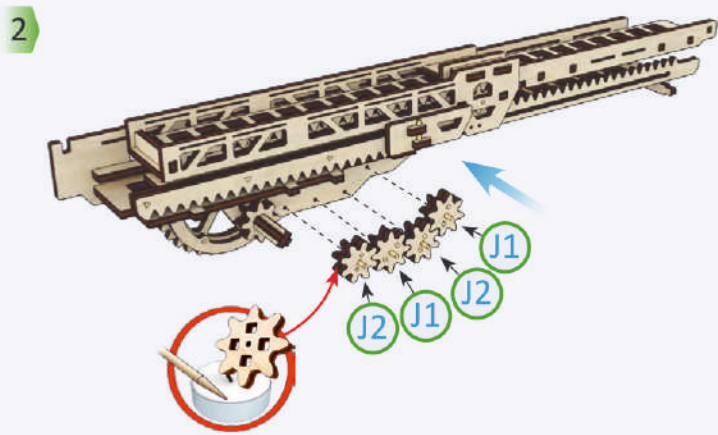
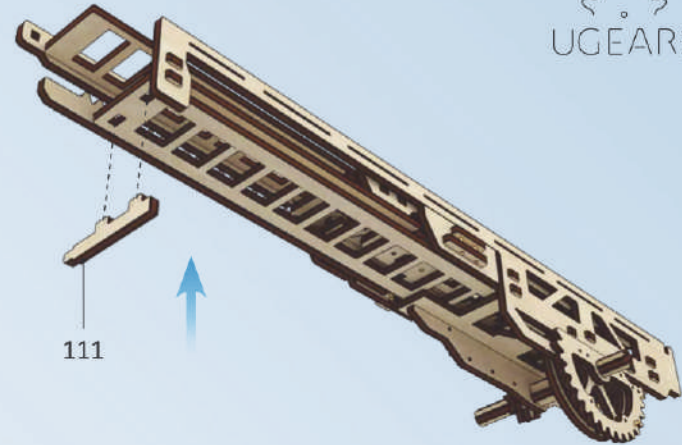
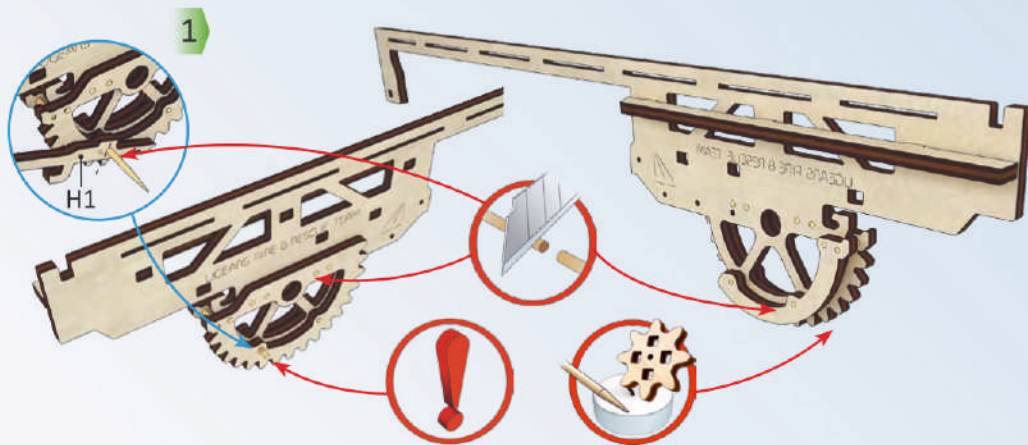
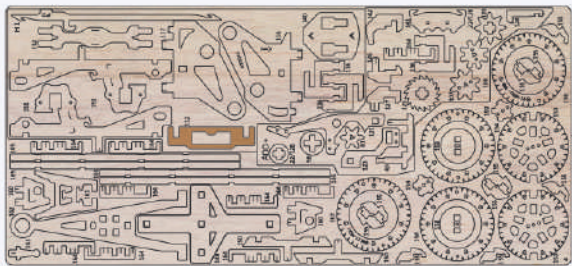
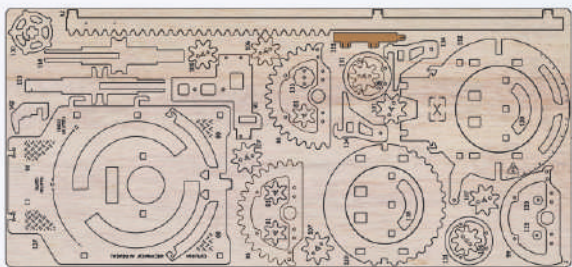

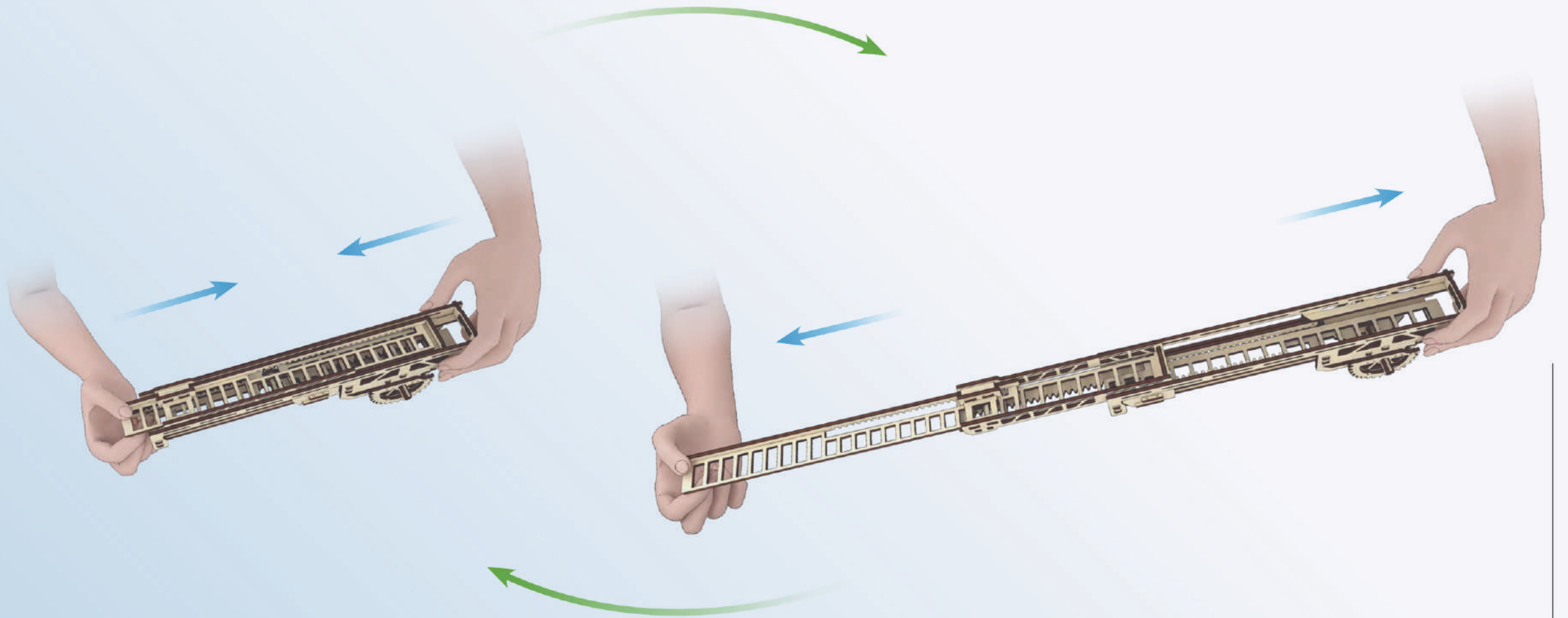

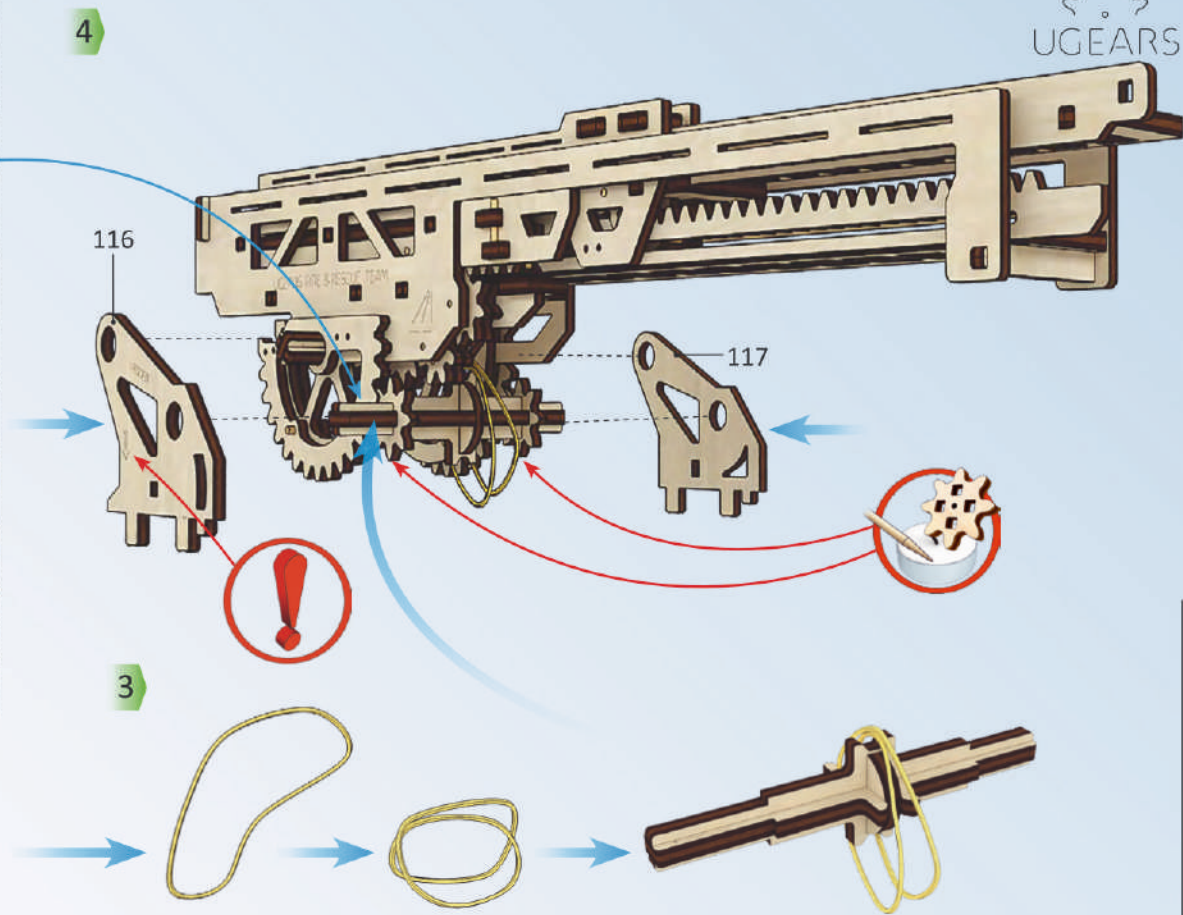
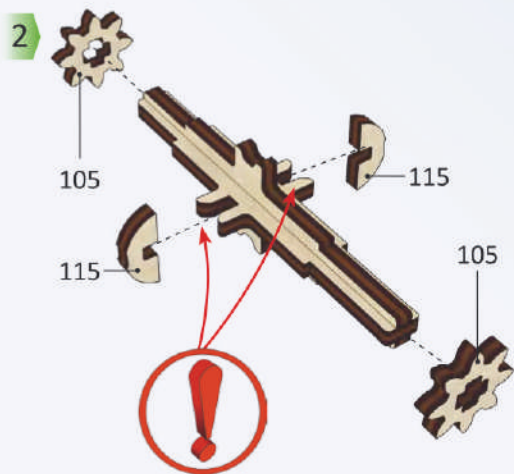
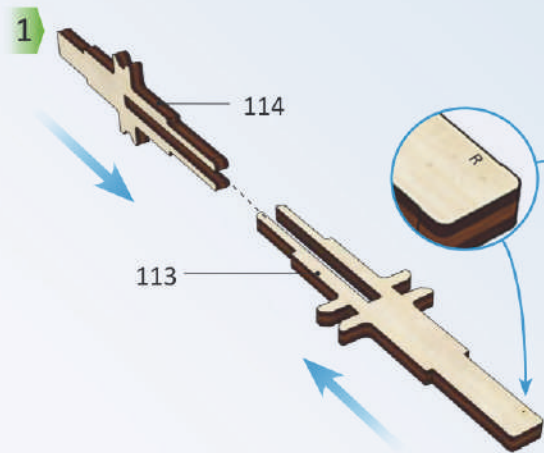
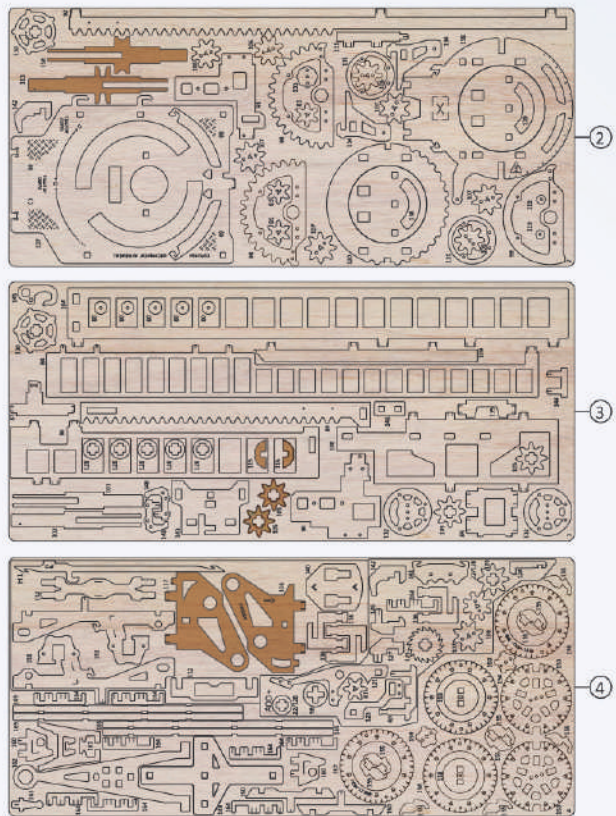

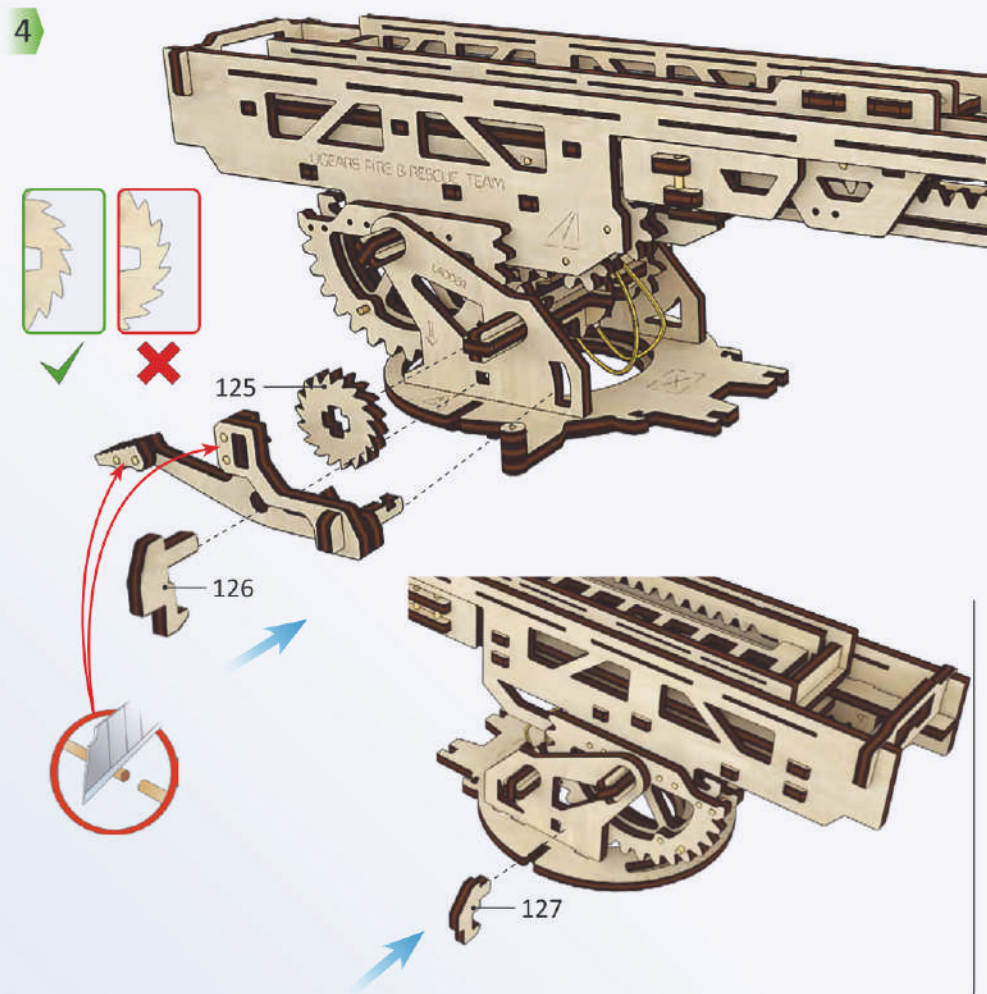
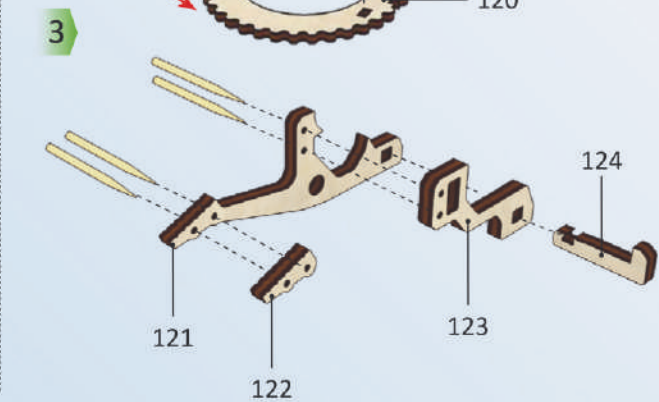
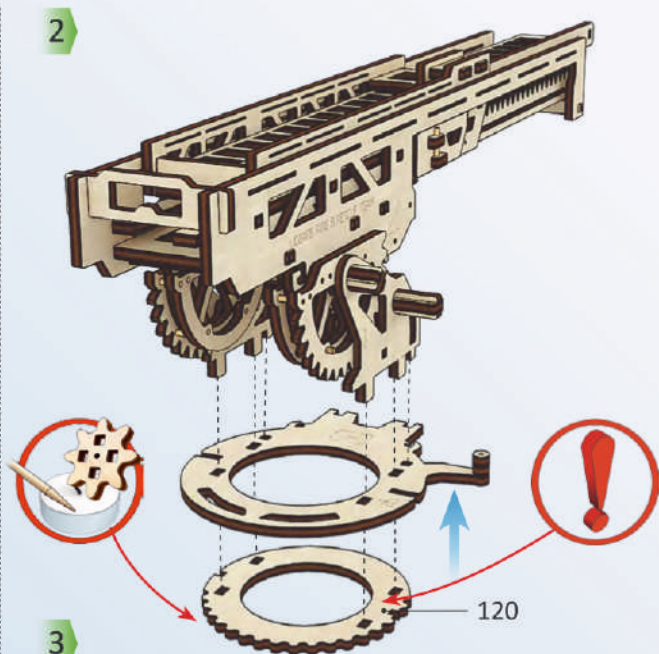
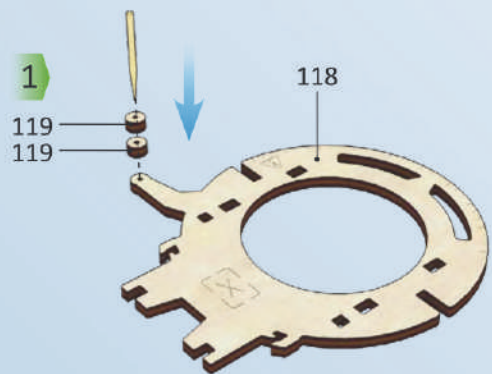
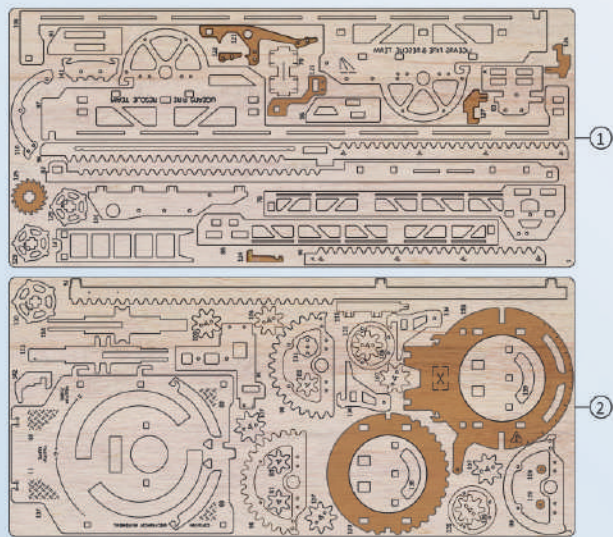

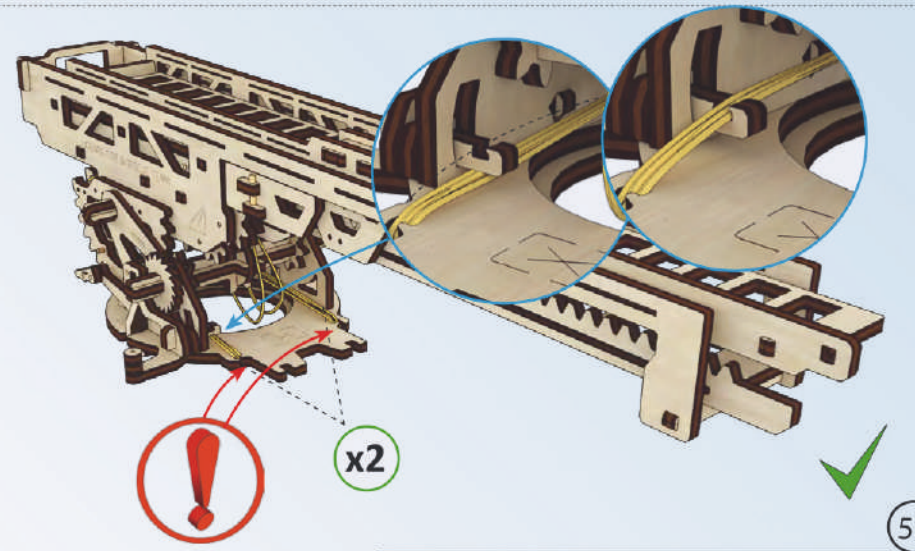
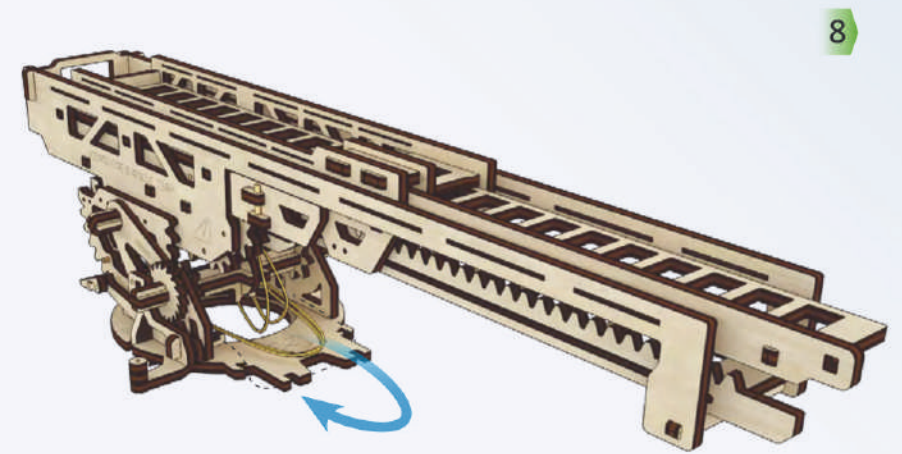
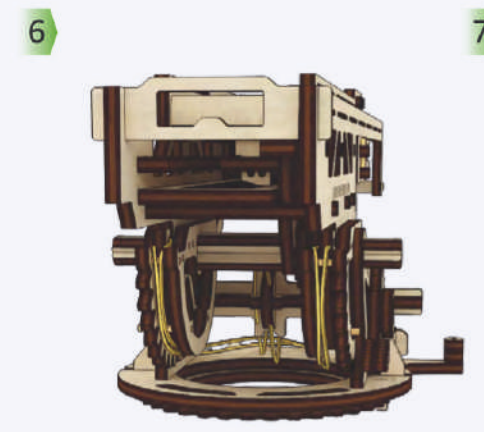
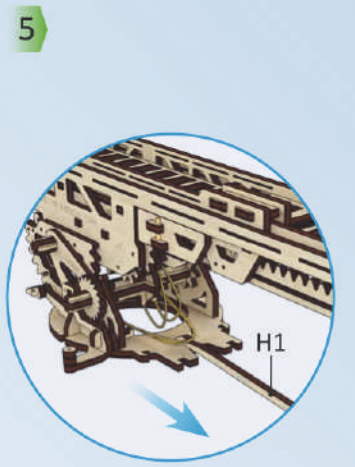
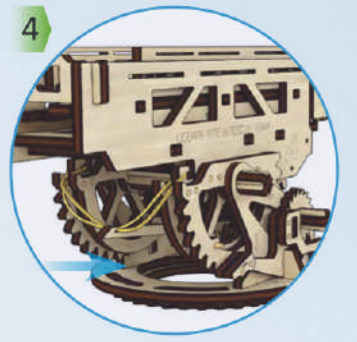
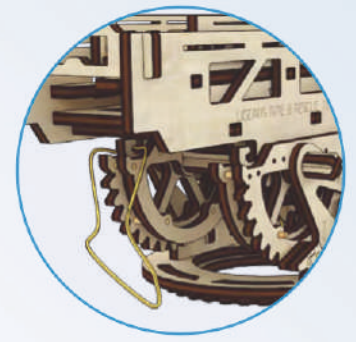
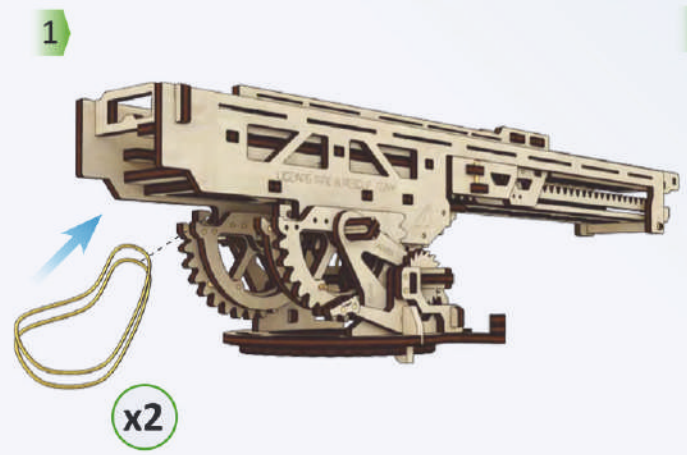

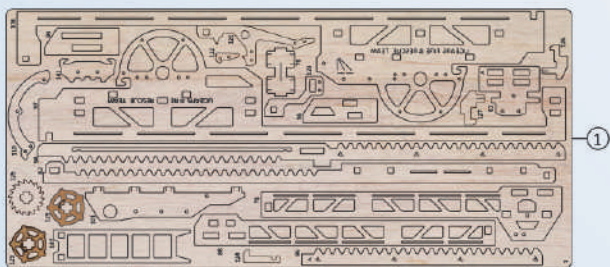

1

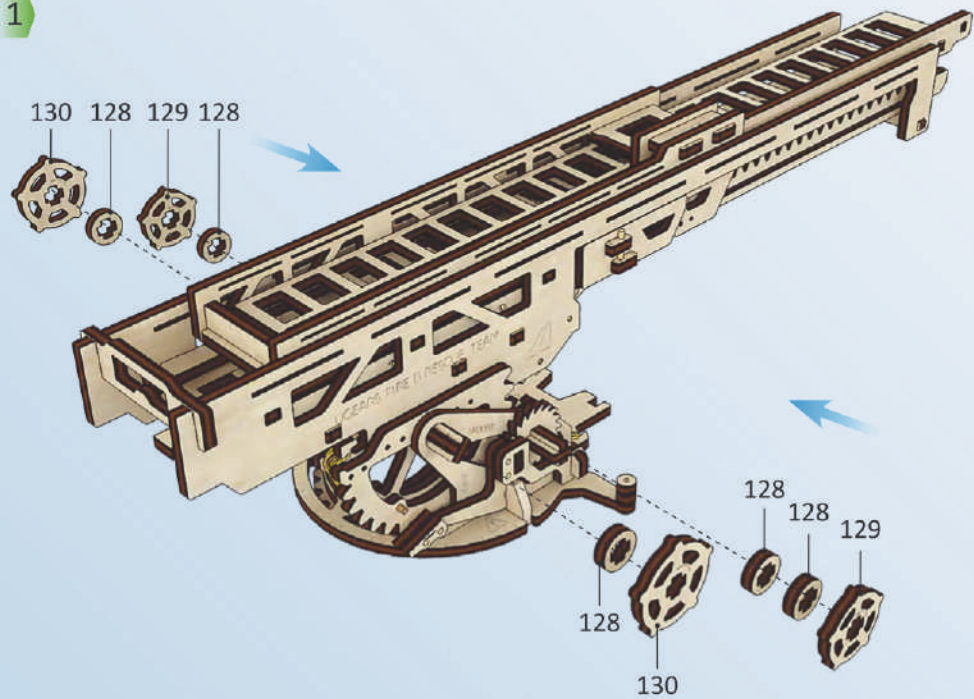

2

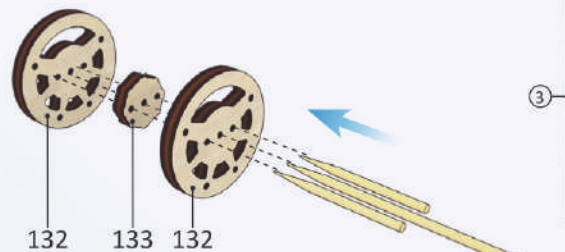

3

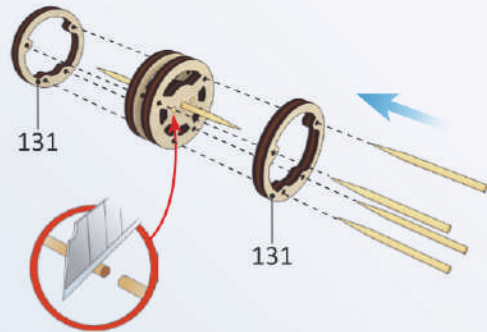

3

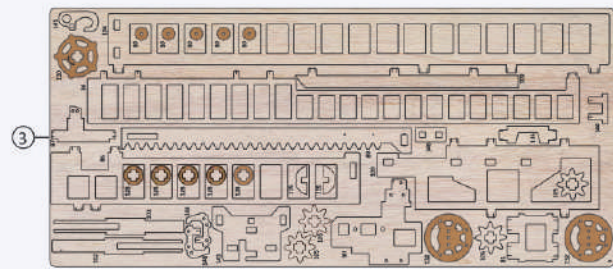

4

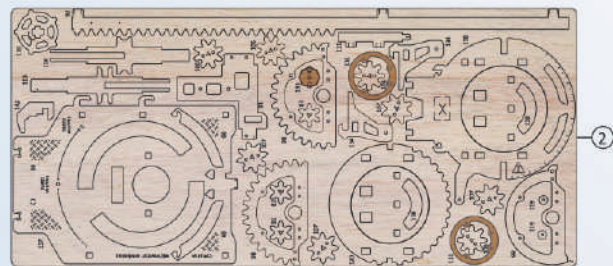
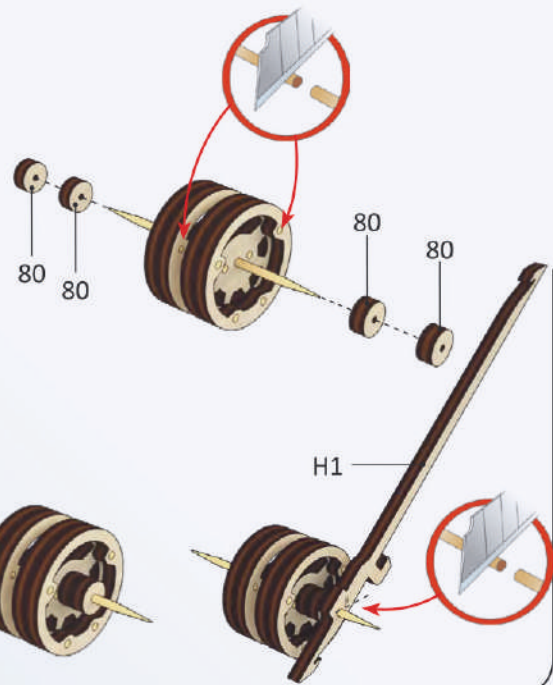

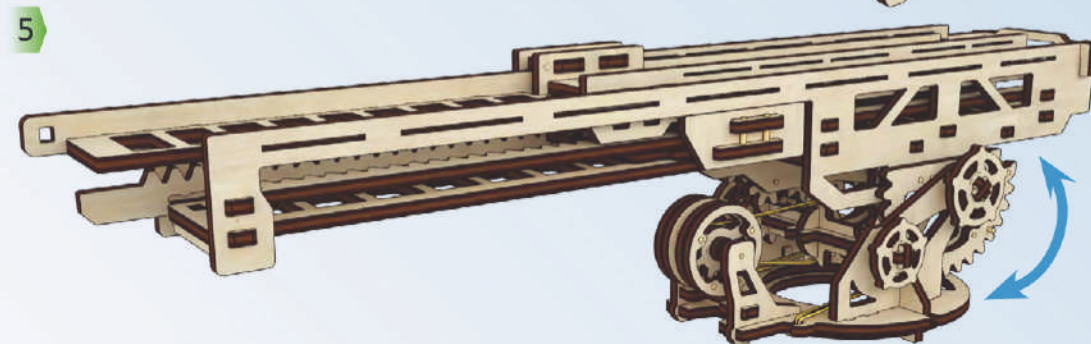
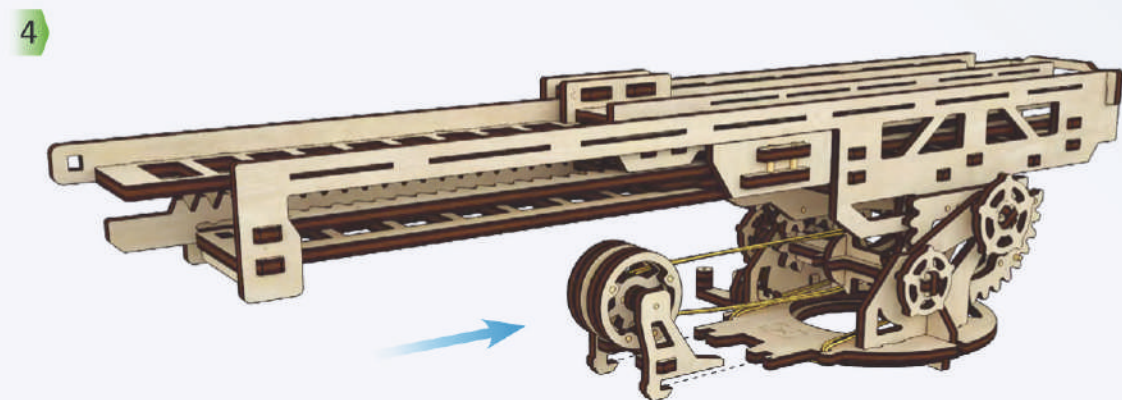
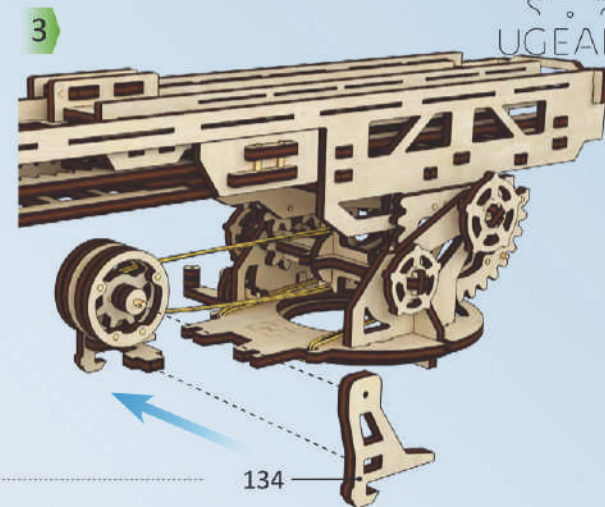
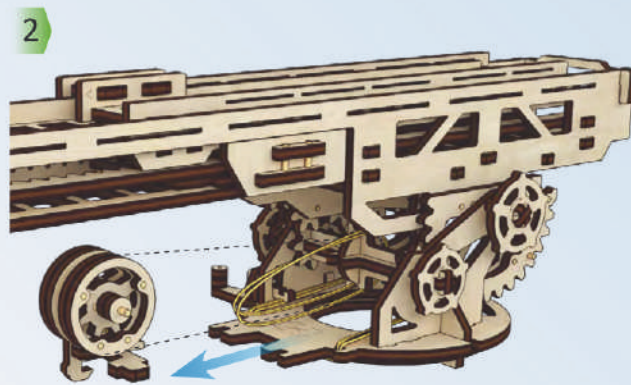
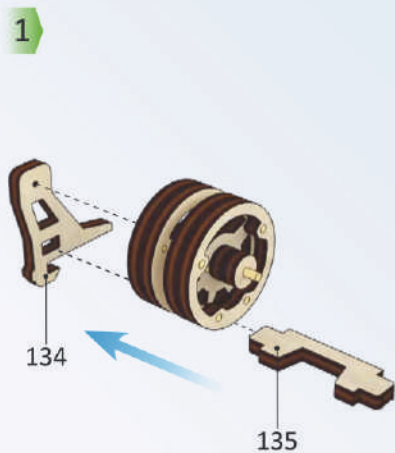
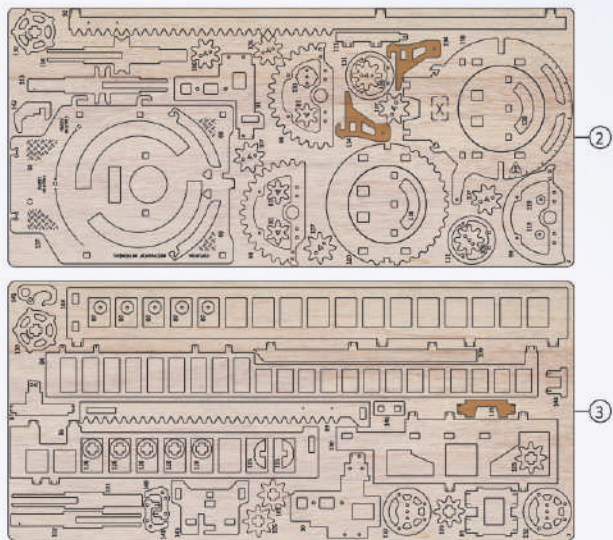

ENG Neatly turn it around. UKR Акуратно поверніть. DEU Einmal vorsichtig umdrehen. FRA Tournez doucement. POL Starannie obrócić dookoła. SPA Cuidadosamente déle la vuelta. ITA Girare con la dovuta calma. TUR Dikkatli döndürün. RUS Аккуратно поверните. KOR 부드럽게 돌아가야 합니다. CHI 轻轻地旋动

1

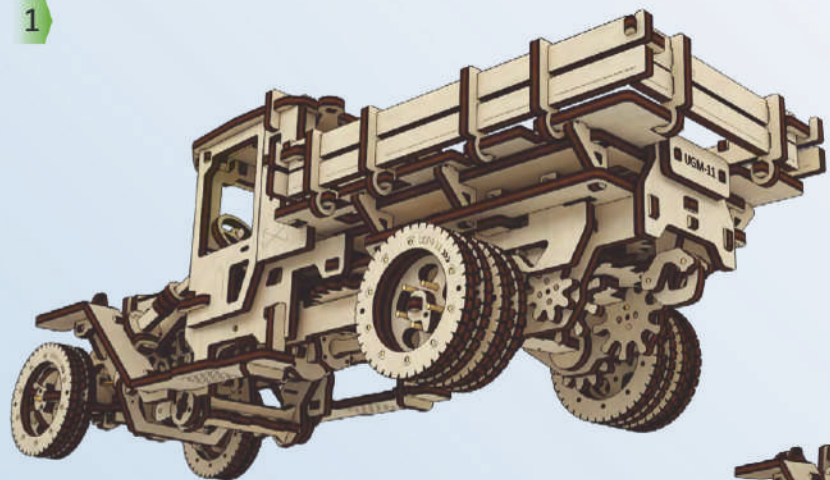

2

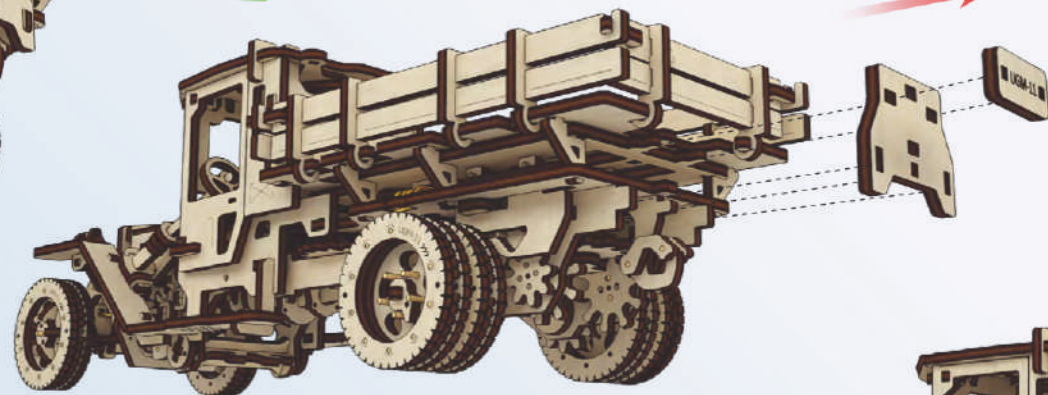

3

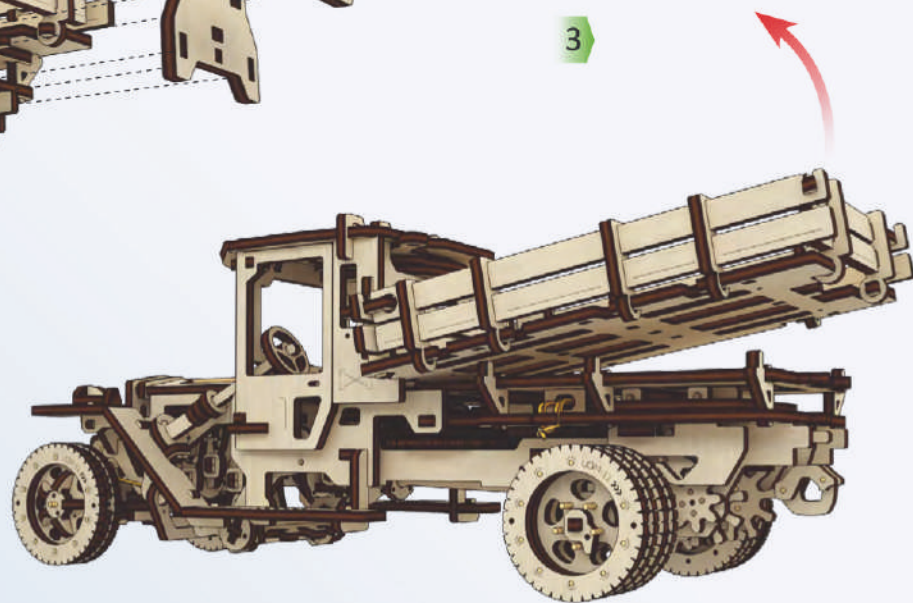

ENG Carefully remove the car body. UKR Акуратно зніміть кузов. DEU Entfernen Sie vorsichtig den Pritschenaufbau. FRA Retirez délicatement la carrosserie du camion. POL Delikatnie zdjąć karoserię. SPA Extraiga cuidadosamente el cuerpo del coche. ITA Rimuovere il cassone con la dovuta calma. TUR Römorku dikkatlice çıkarılın. RUS Аккуратно демонтируйте кузов. KOR 적재함을 조심스럽게 분리해 주세요. CHI 小心地拆卸车体。



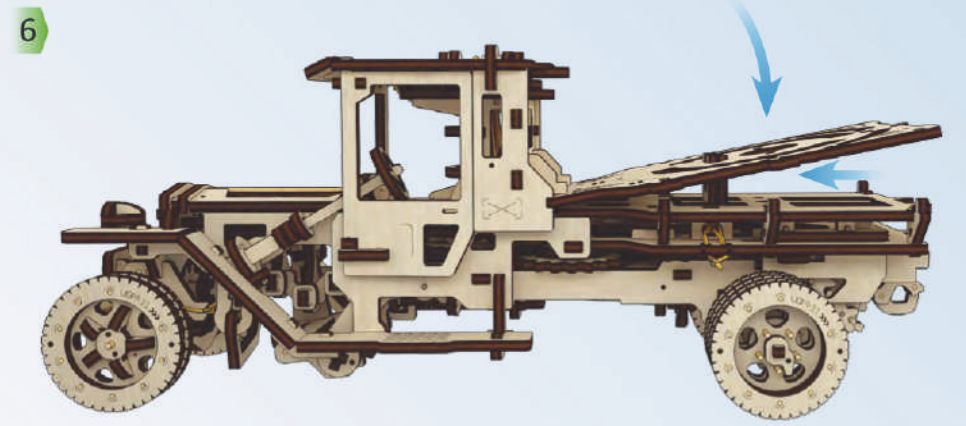
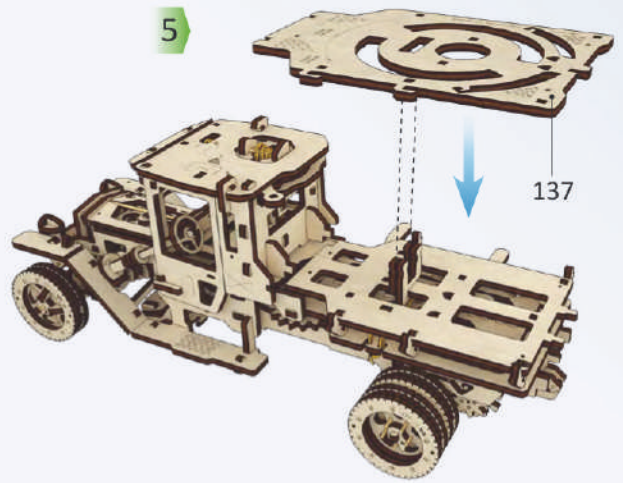
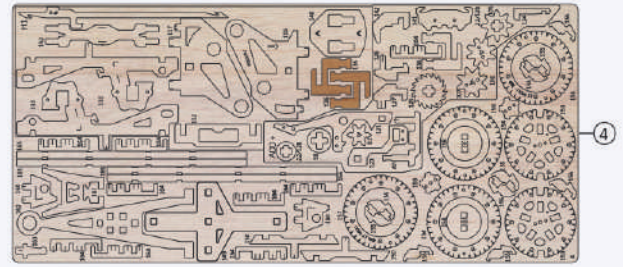
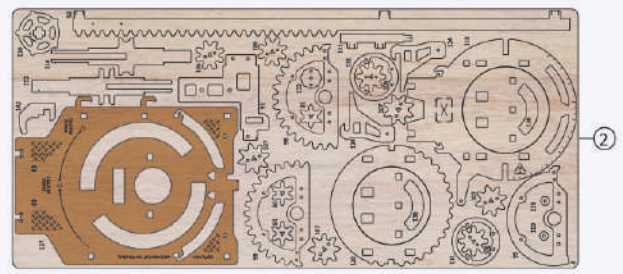
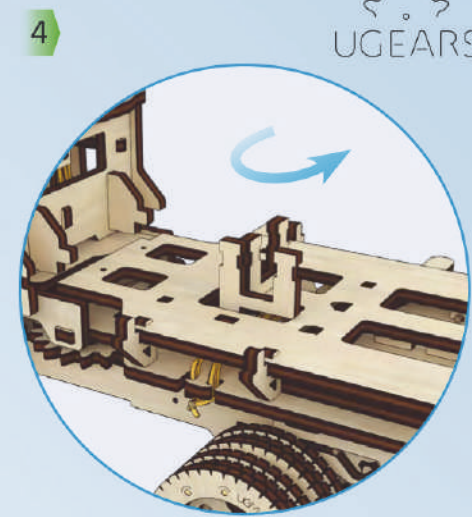
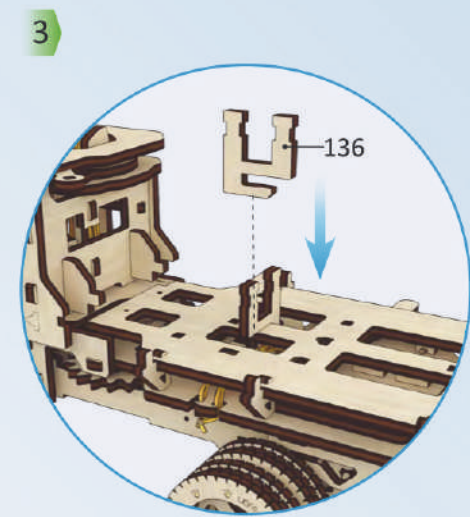
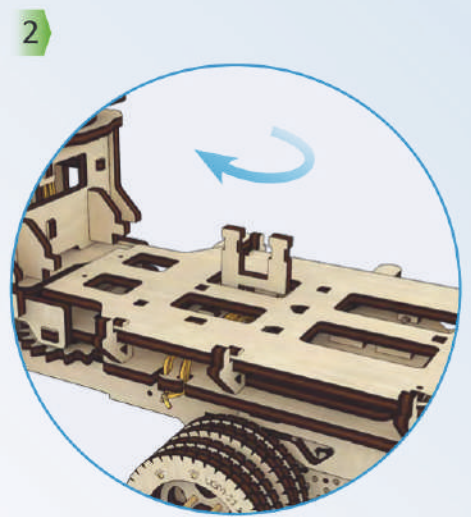
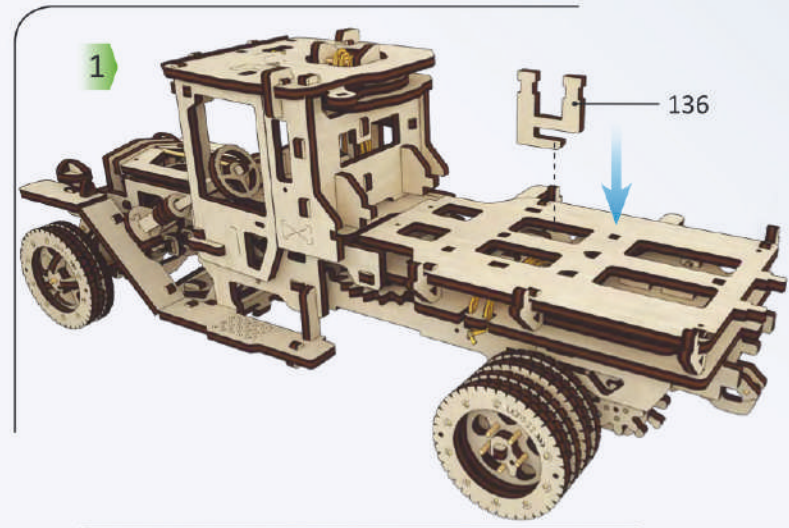

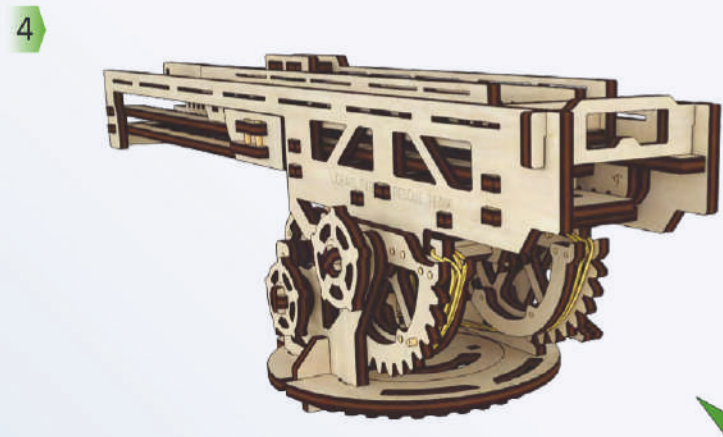
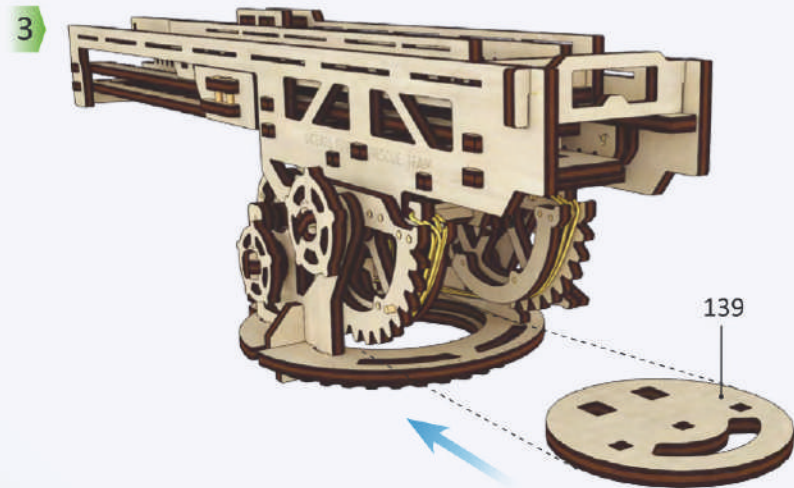
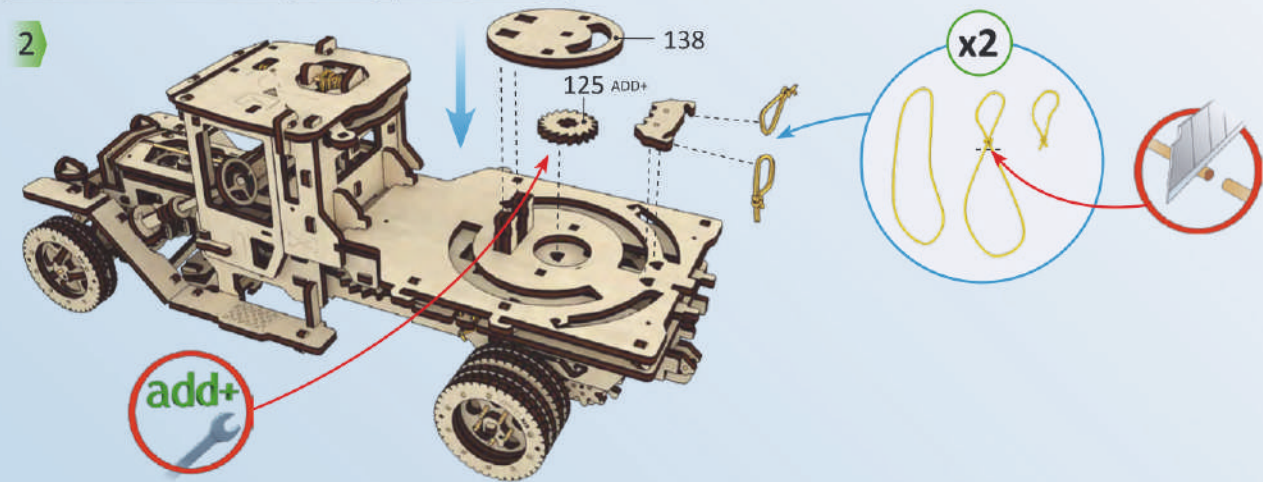
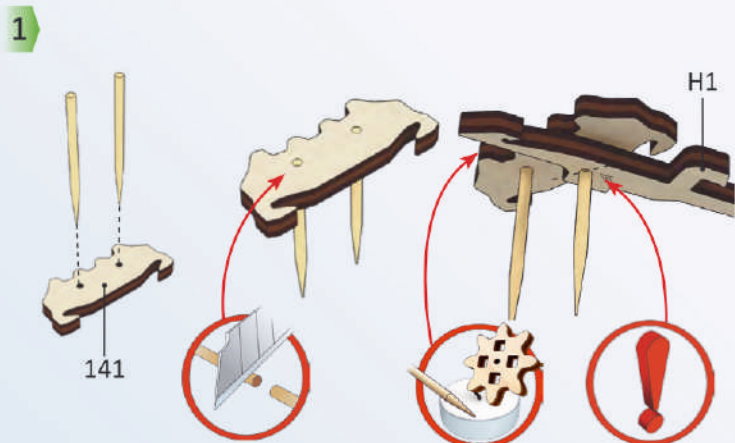
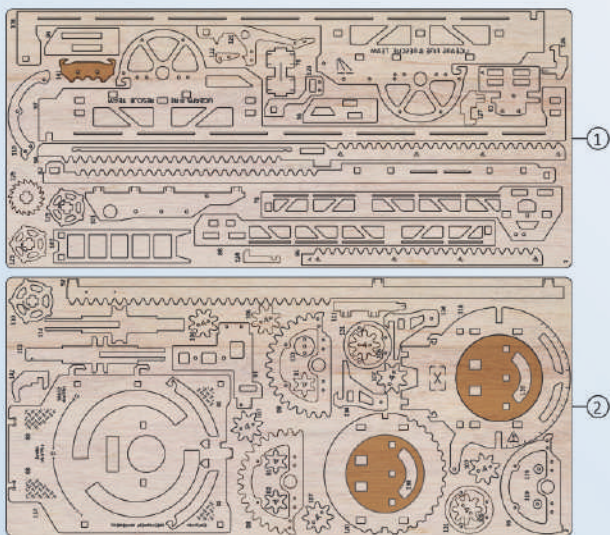

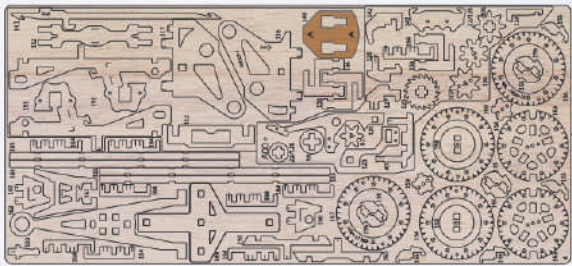

1

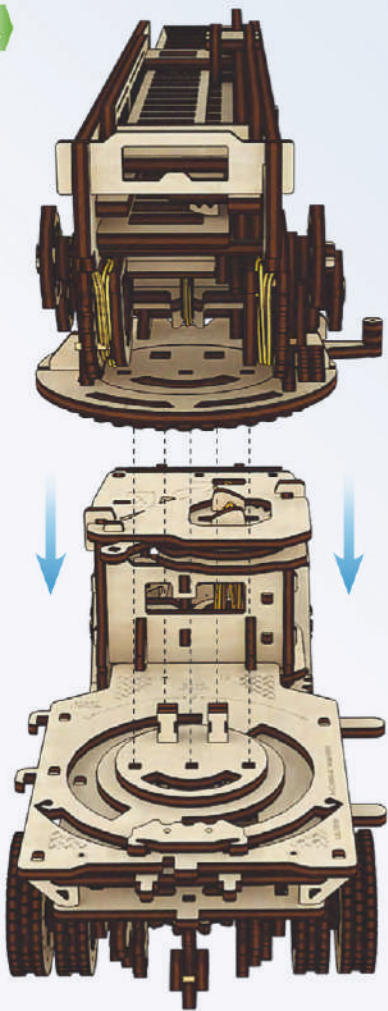

2

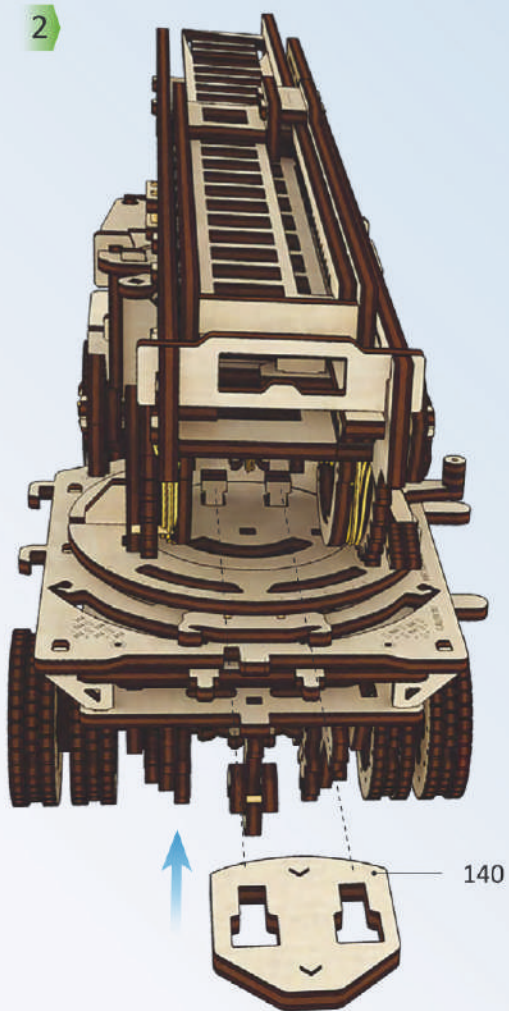

3

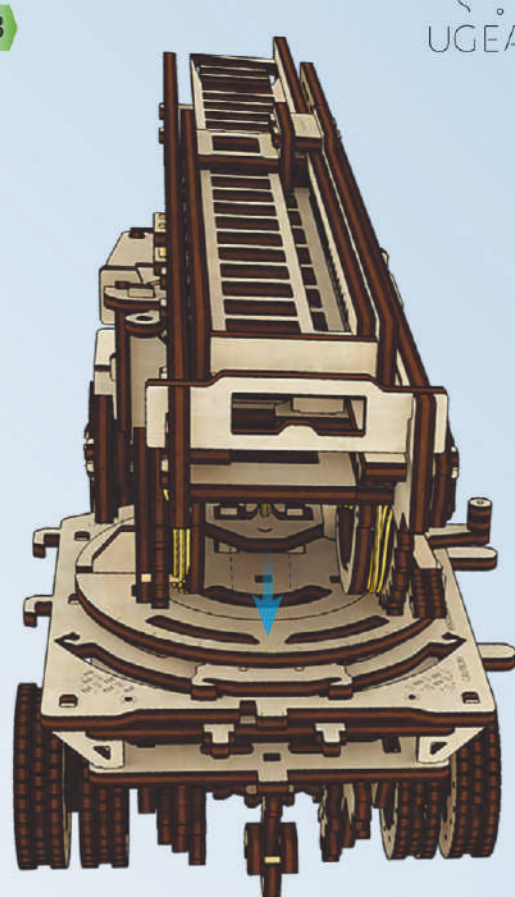

1



2



3



ENG Press the piece all the way in. UKR Притисніть деталь до упору. DEU Drücken Sie das Bauteil bis zum Anschlag ein. FRA Appuyez sur la pièce jusqu'en butée. POL Delikatnie dociskać część aż do momentu poczucia oporu. SPA Presione la pieza hasta que haga tope. ITA Premere il complemento aggiuntivo a fondo. TUR Parçayı sonuna kadar bastırın. RUS Прижмите деталь до упора. KOR 누르고 밀어서 끼워 넣습니다. CHI 把消防梯压住到底。

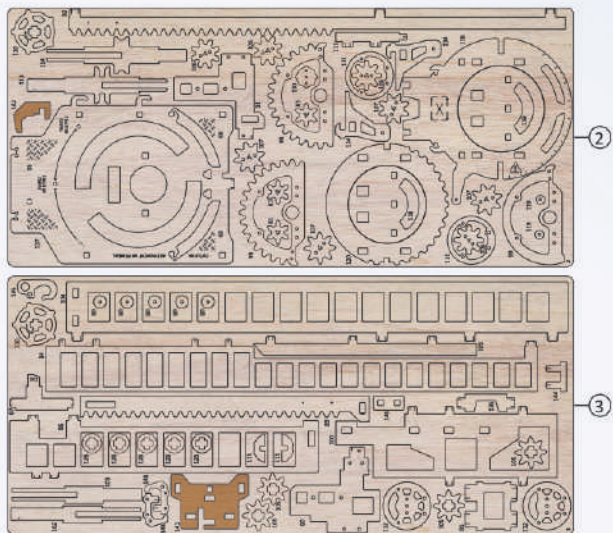

1

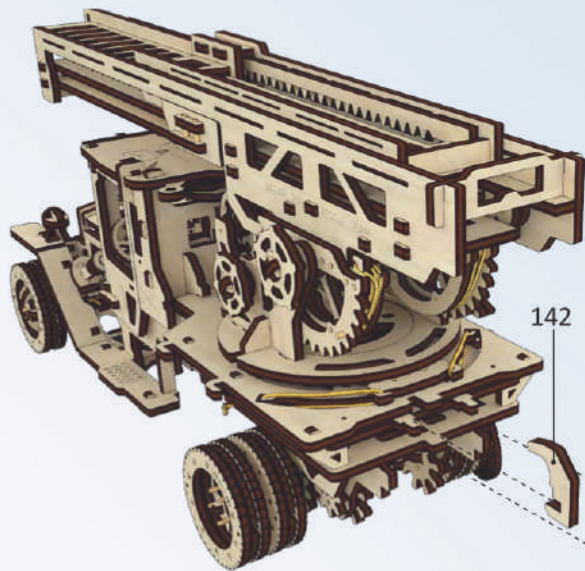

2

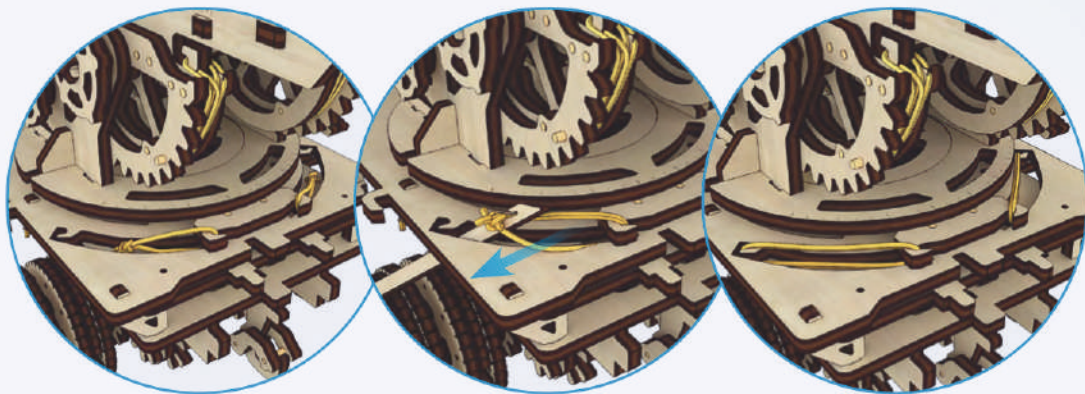
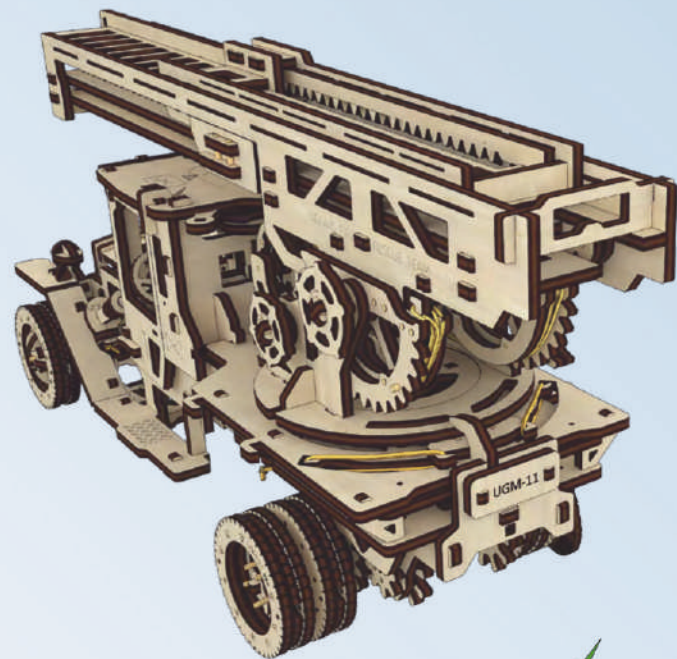
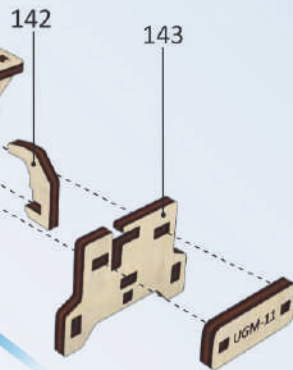

ENG The band should be tight. UKR Гумка повинна бути натягнута. DEU Das Gummi muss gespannt sein. FRA L'élastique doit être serré. POL Gumka powinna być napięta. SPA El elástico debe ser ajustado. ITA L'elastico deve essere teso a sufficienza. TUR Lastik gerilmiş olmalıdır. RUS Резинка должна быть натянута. KOR 고무밴드의 장력은 팽팽해야 합니다. CHI 橡皮筋必須拉緊



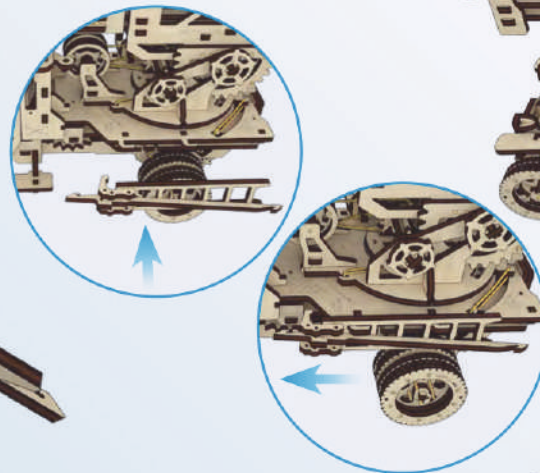
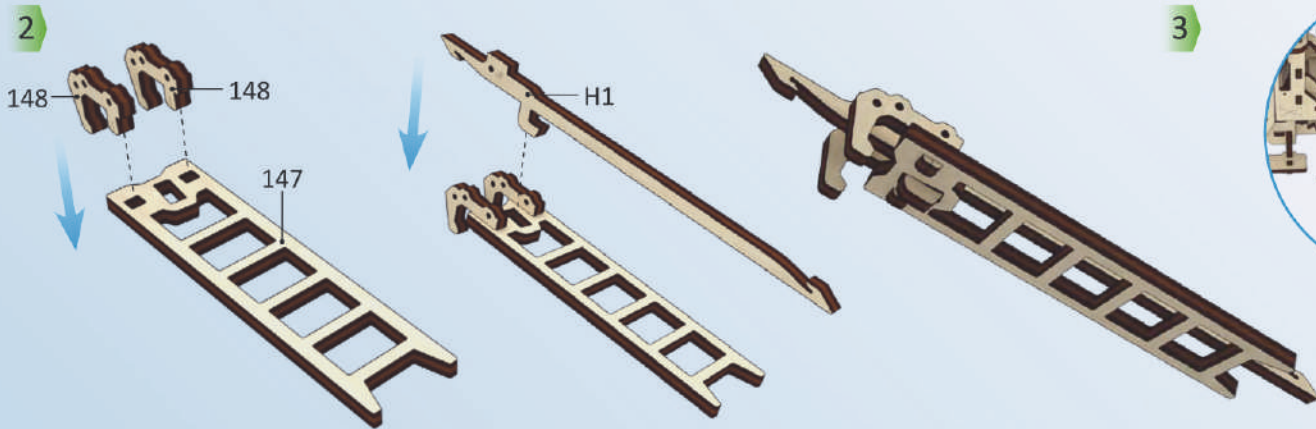
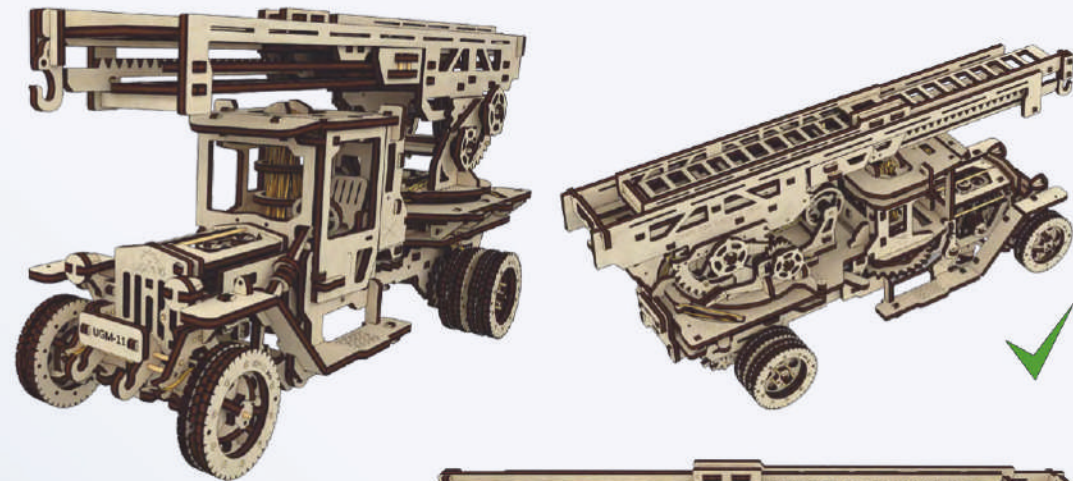
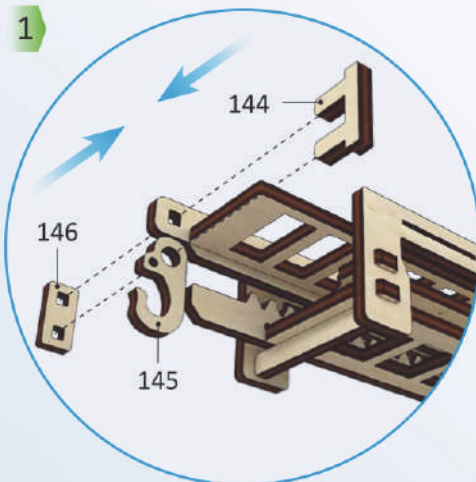
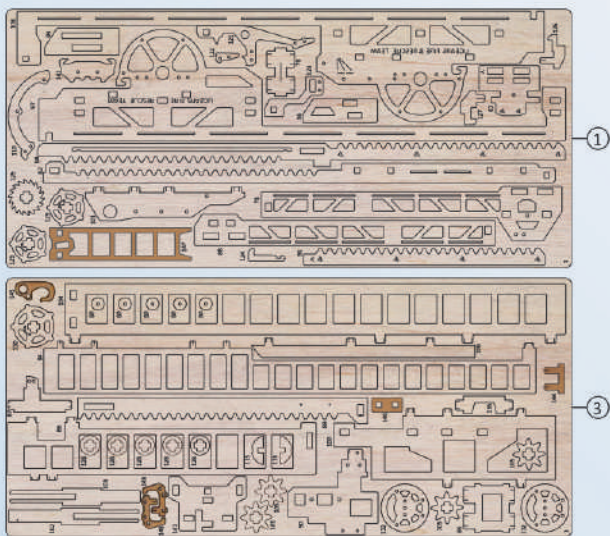

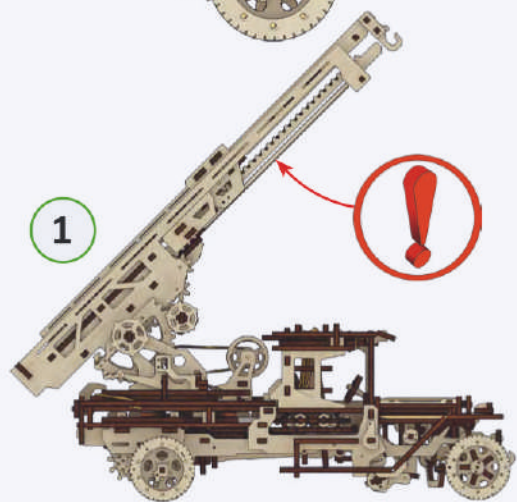
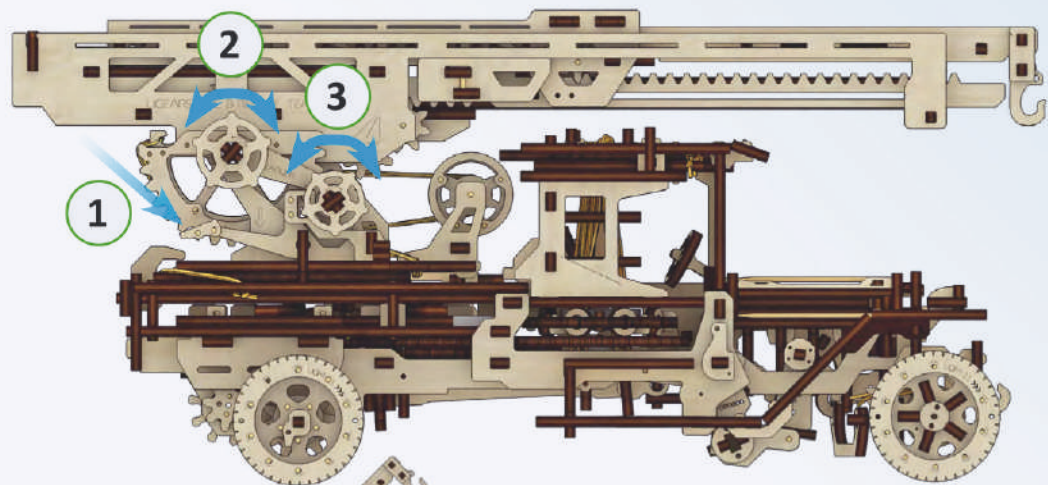

ENG Caution! The abrupt ascent of the ladder! UKR Обережно! Різкий підйом драбини! DEU Vorsicht! Die Leiter fährt abrupt aus! FRA Attention à la montée rapide de l'échelle! POL Uwaga! Drabina otwiera się gwałtownie! SPA ¡Precaución! La brusca subida de la escalera! ITA Attenzione! al sollevamento della scala. TUR Dikkat! Merdivenin aniden kaldırılması! RUS Осторожно! Резкий подъем лестницы! KOR 주의! 사다리의 갑작스러운 상승에 주의하세요. CHI 注意! 消防梯急剧提升

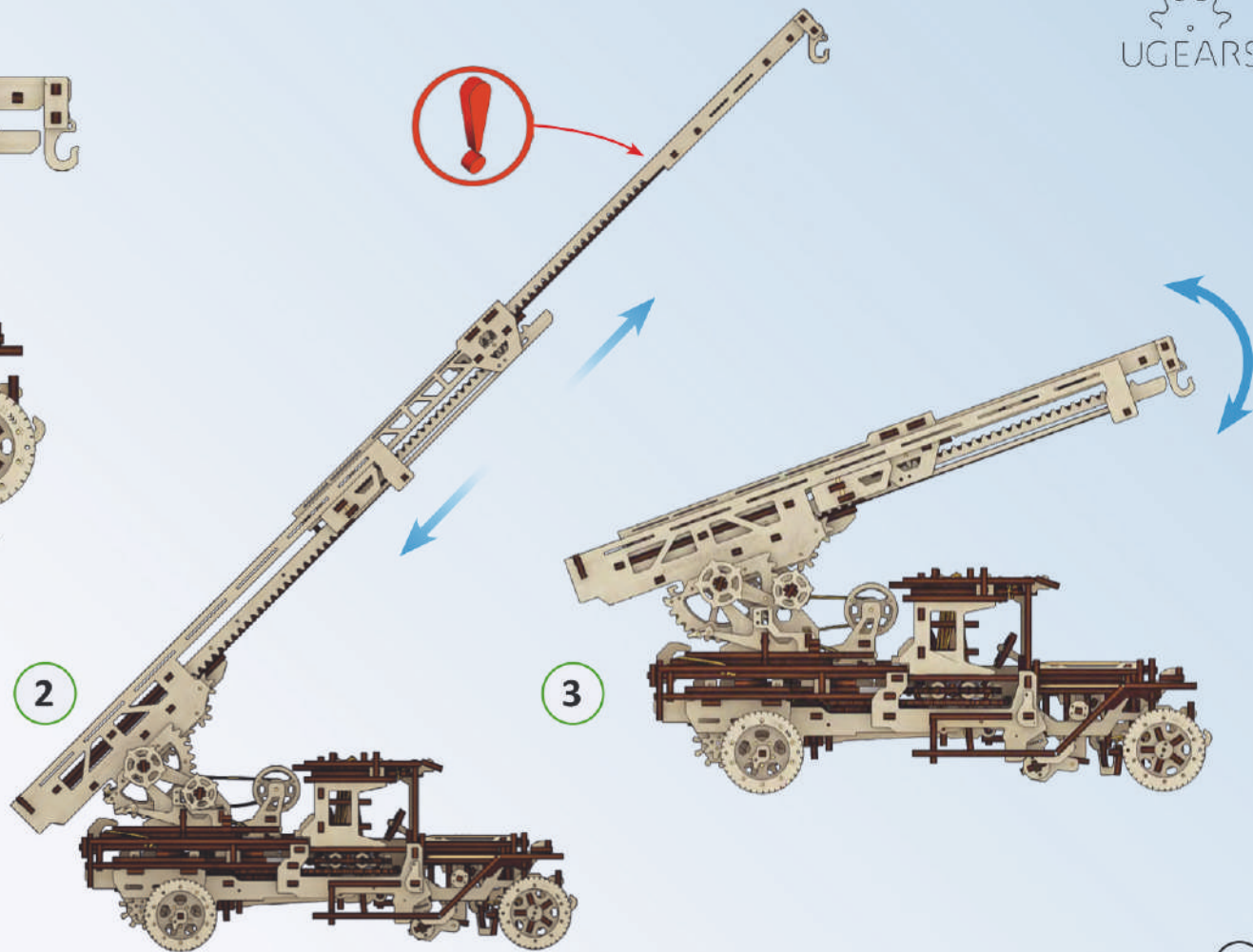

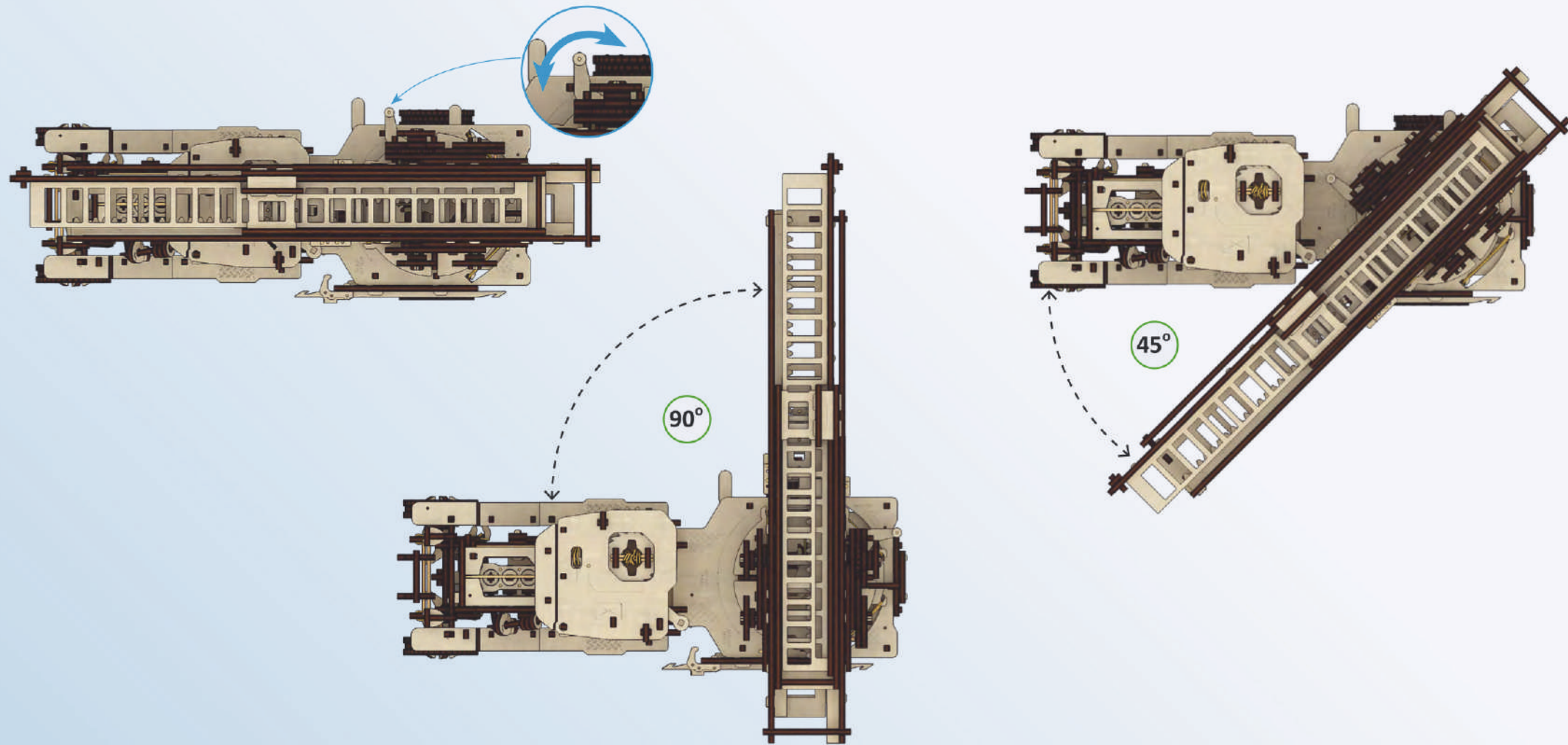







ENG Trailer. UKR Причіп. DEU Anhänger.  
FRA Remorque. POL Naczepę. SPA El acoplado. ITA Rimorchio.  
TUR Tanıtım videosu. RUS Прицеп. KOR 적재함. CHI 拖车

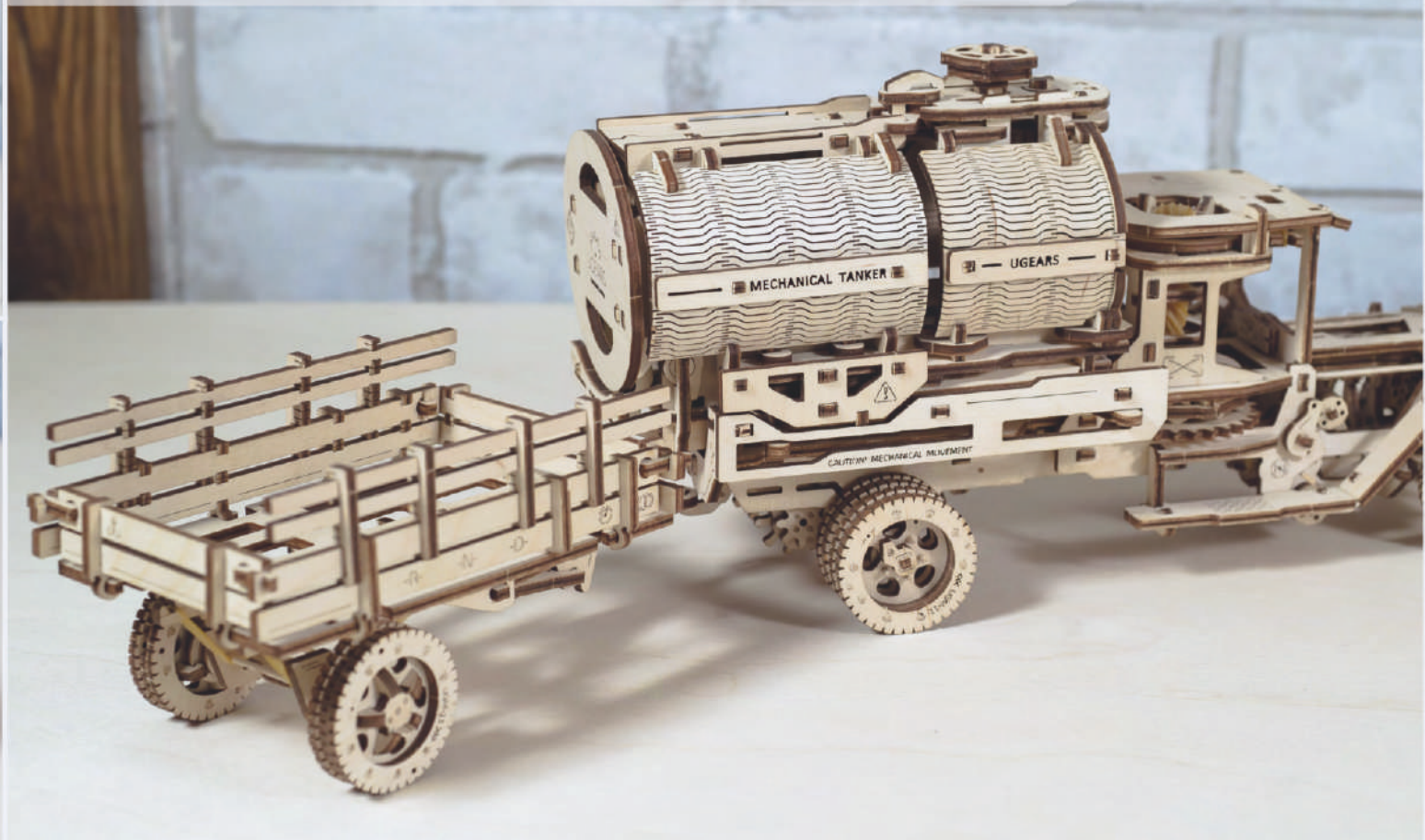

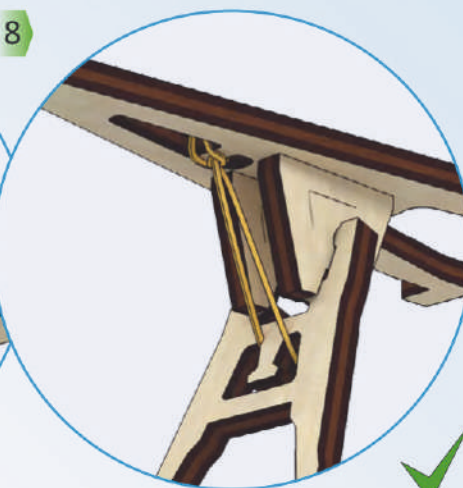
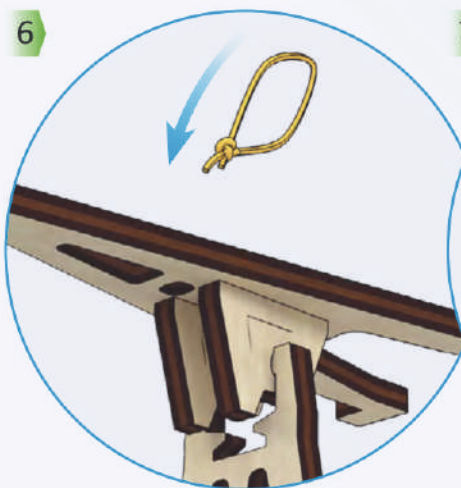
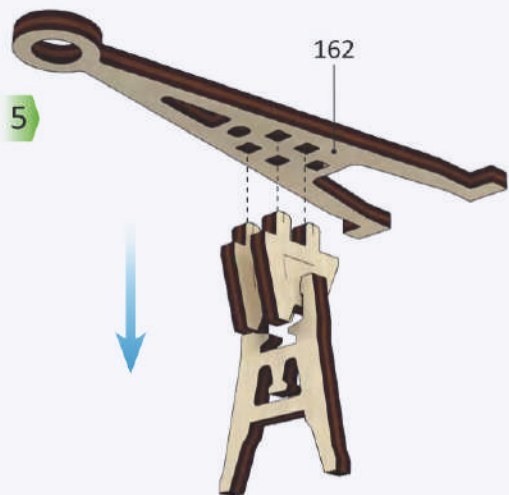
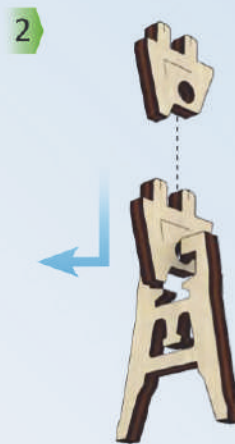
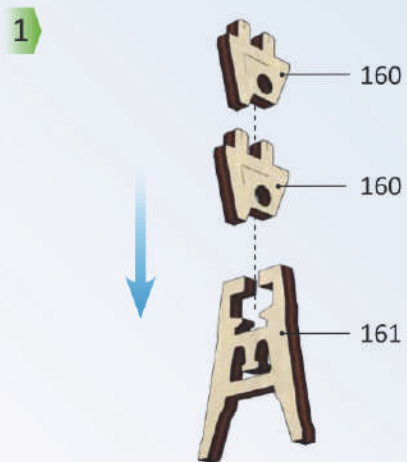
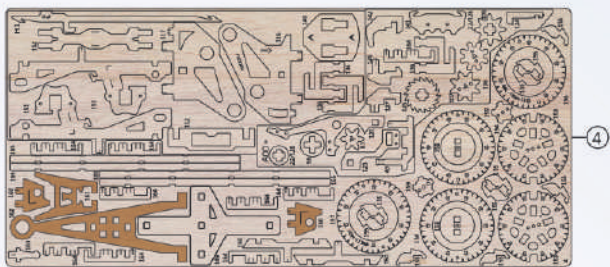

ENG The band should be tight. UKR Гумка повинна бути натягнута. DEU Das Gummi muss gespannt sein. FRA L'élastique doit être serré. POL Gumka powinna być napięta. SPA El elástico debe ser ajustado. ITA L'elastico deve essere teso a sufficienza. TUR Lastik gerilmiş olmalıdır. RUS Резинка должна быть натянута. KOR 고무밴드의 장력은 팽팽해야 합니다. CHI 橡皮筋必須拉緊

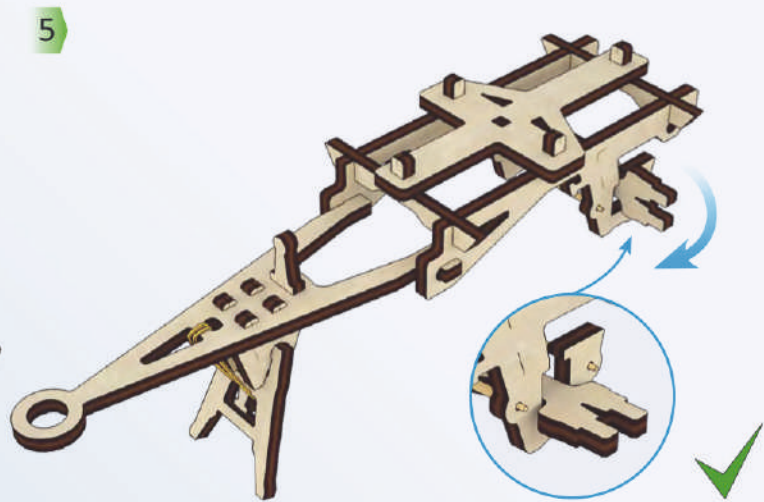
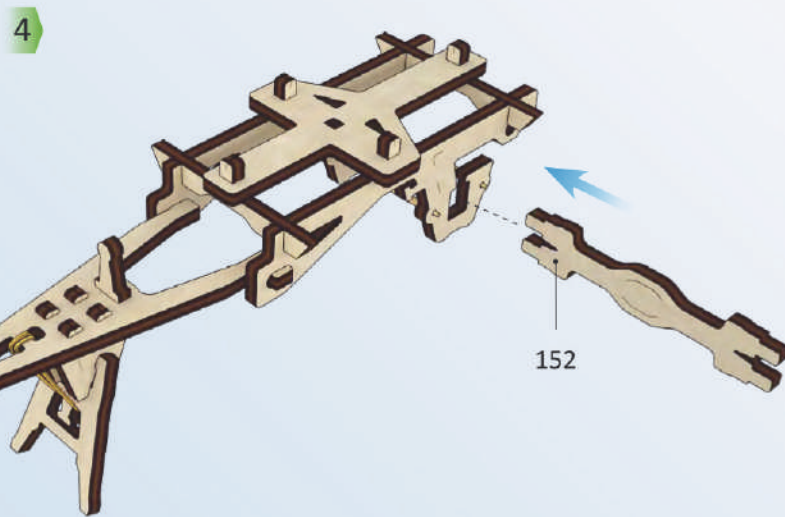
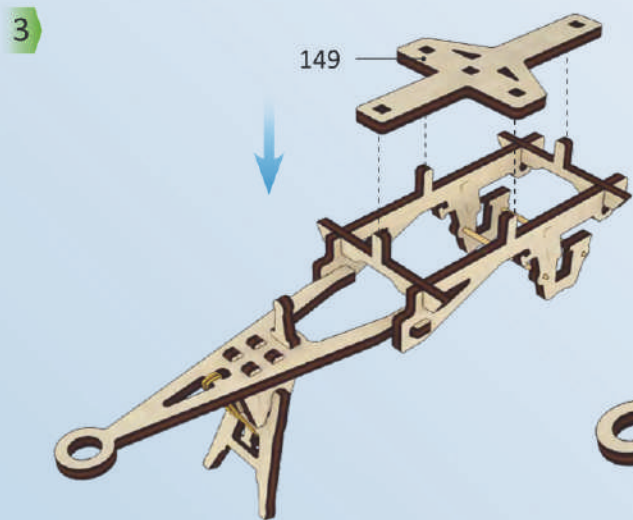
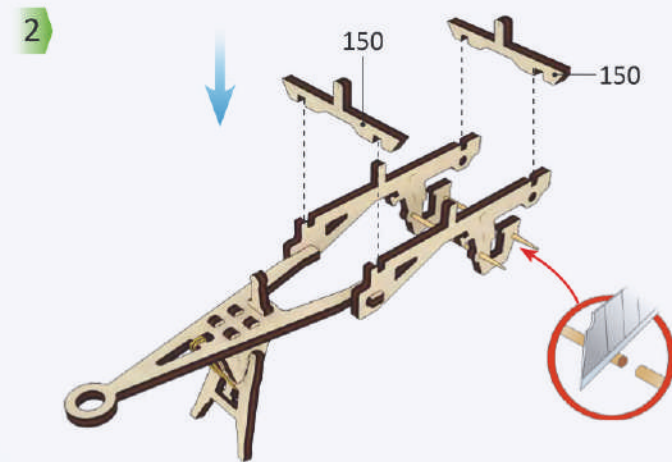
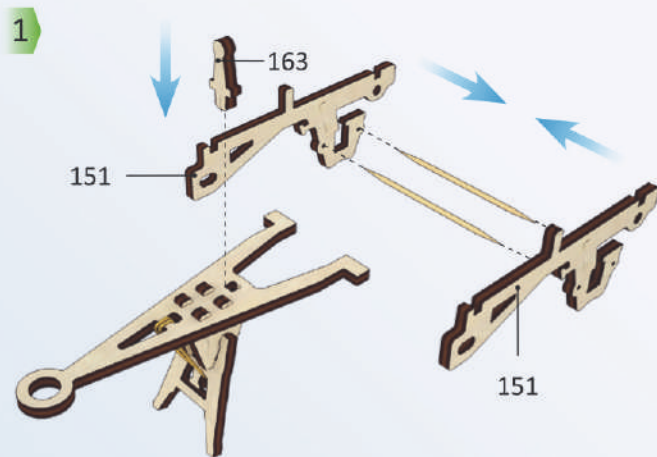
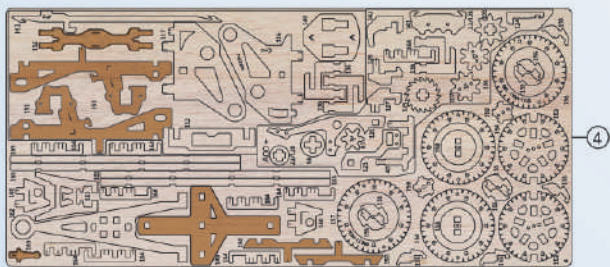

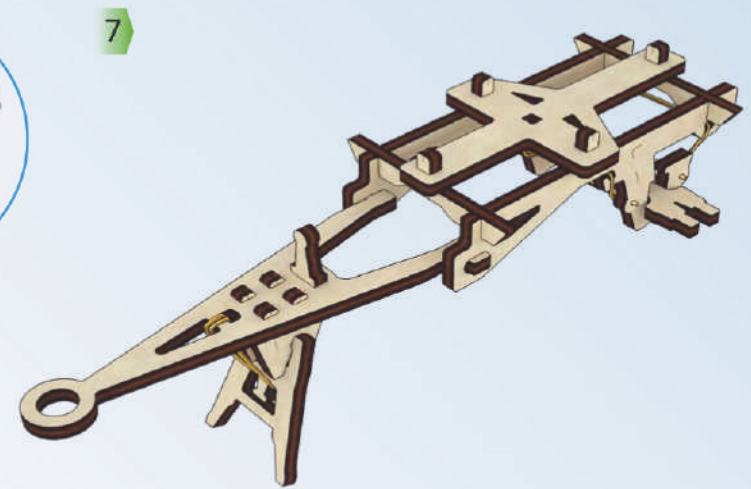
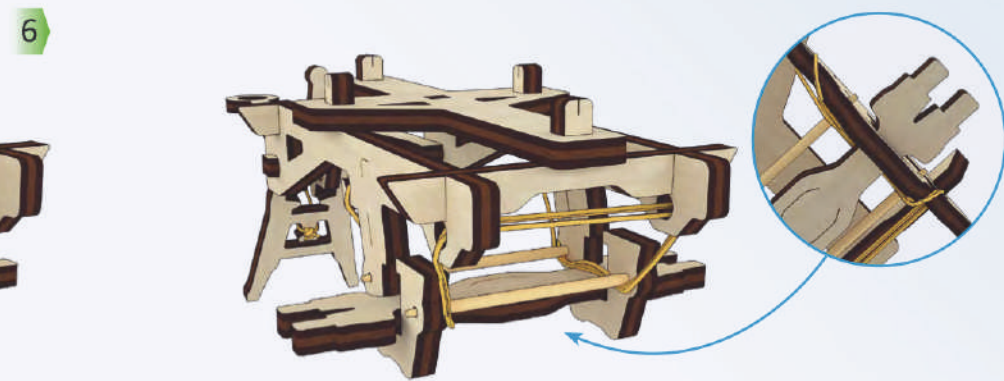
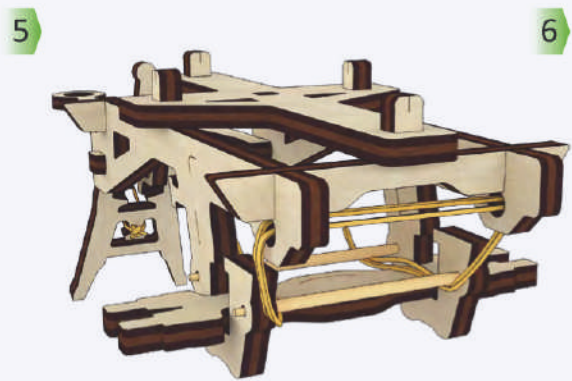
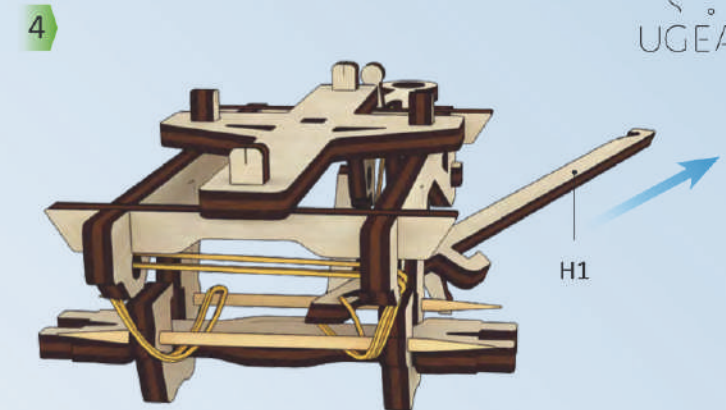
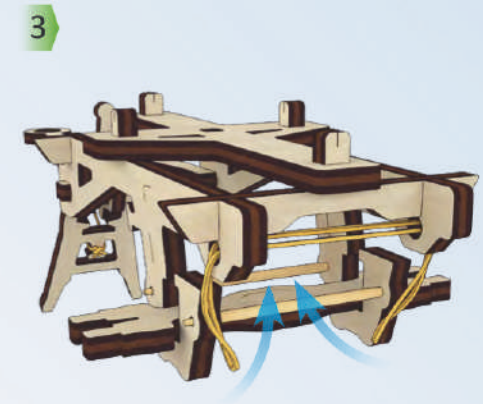
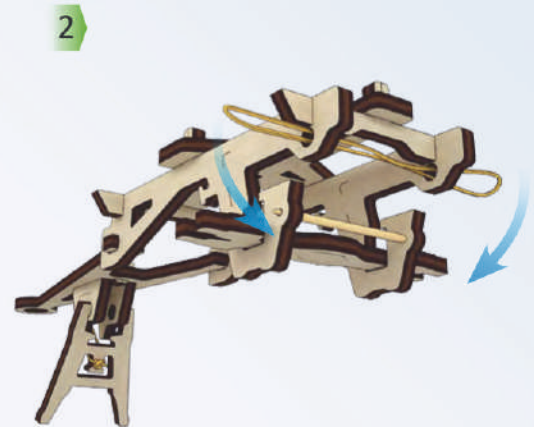
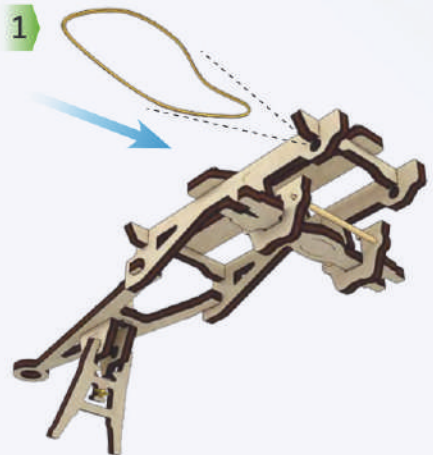

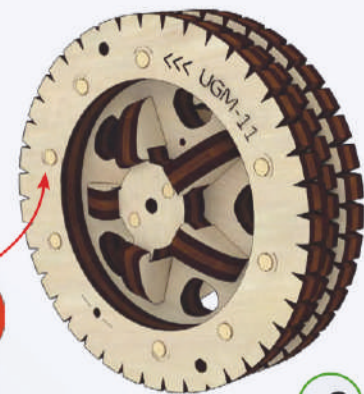
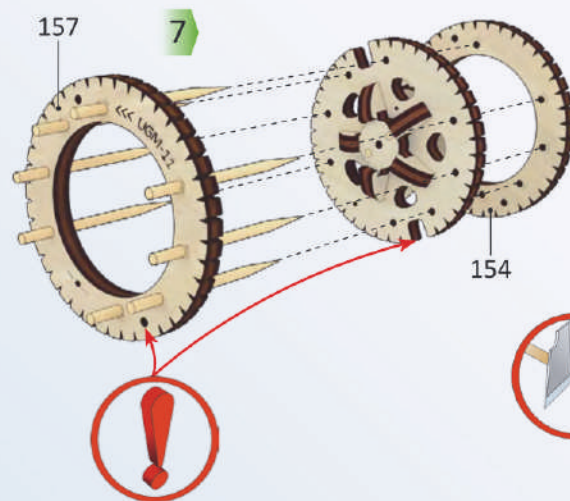
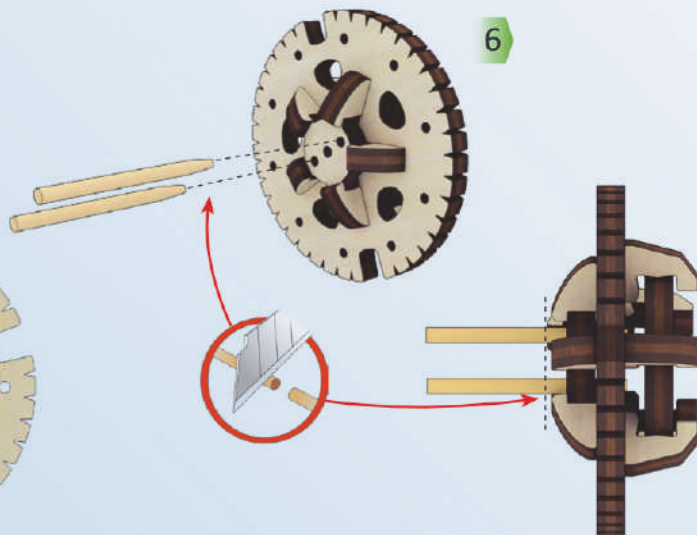
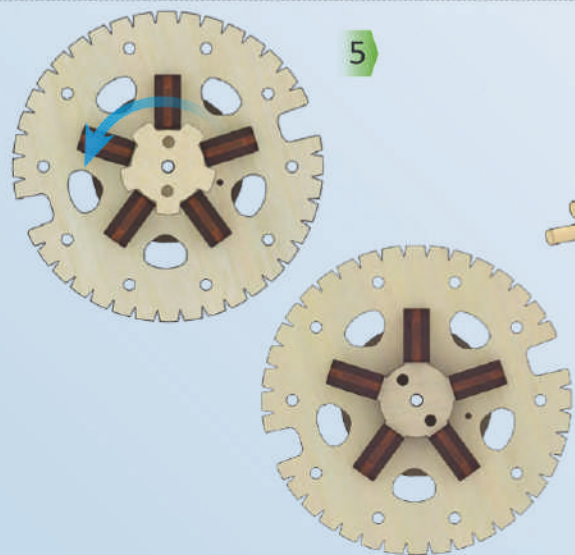
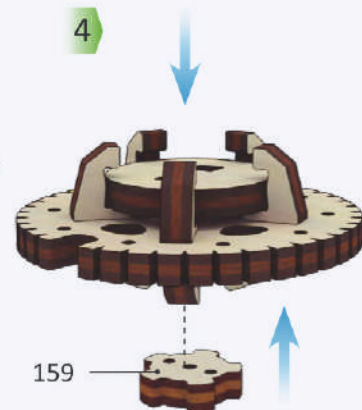
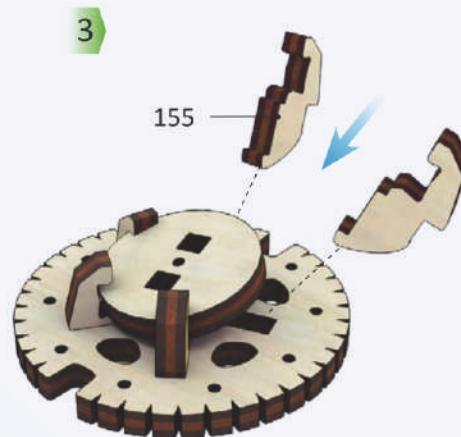
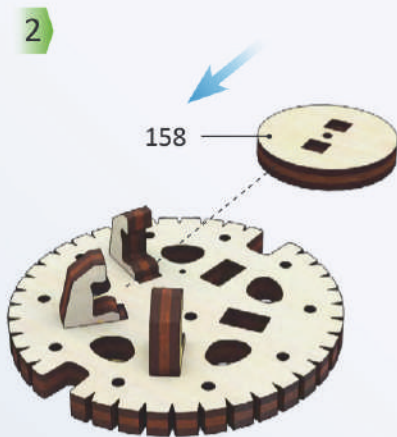
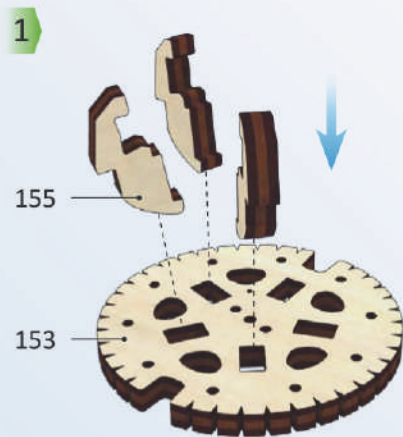
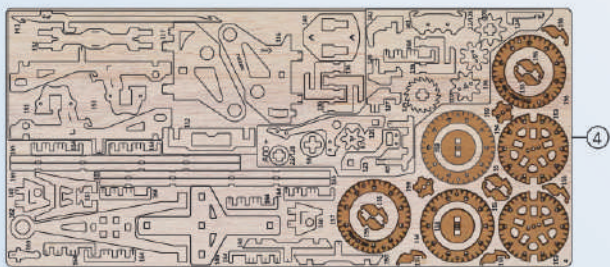

x2

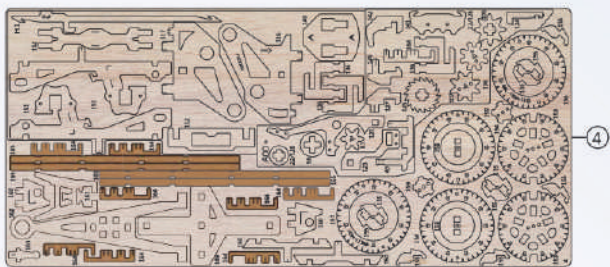

1

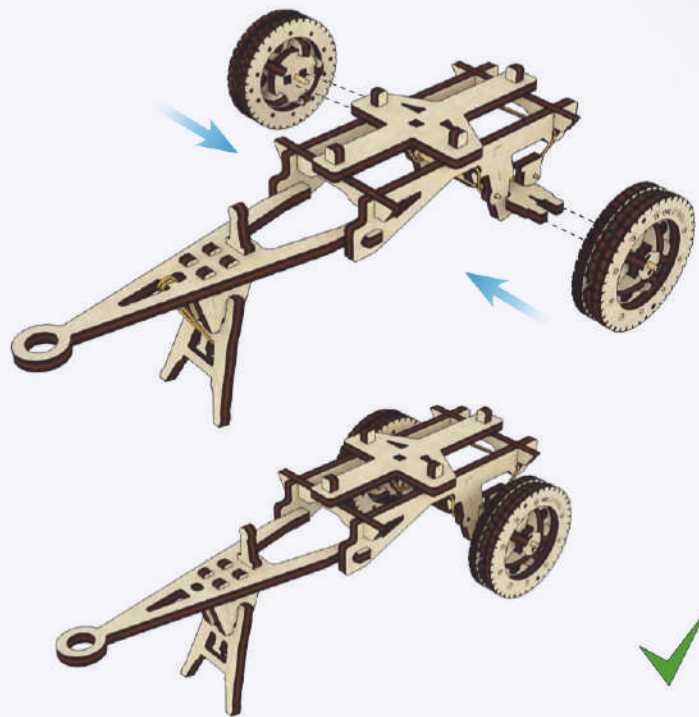

2

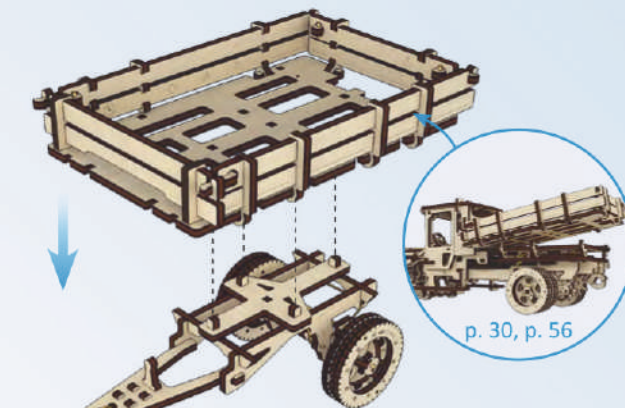

3

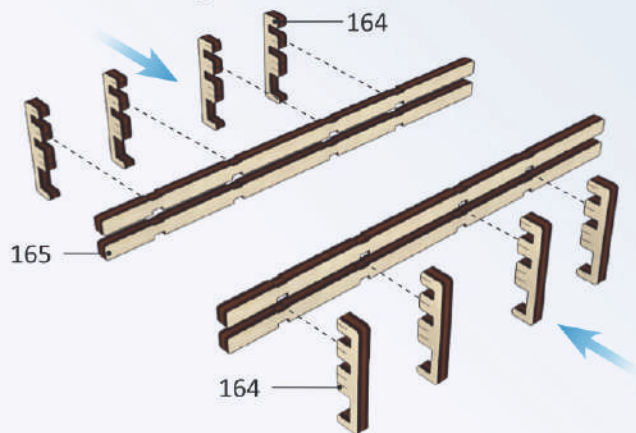

4

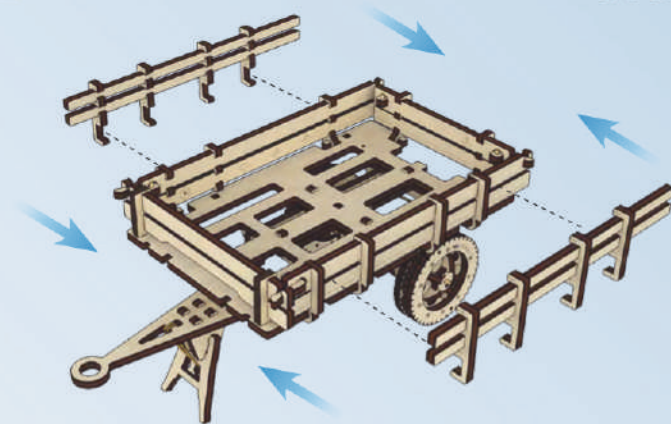

5

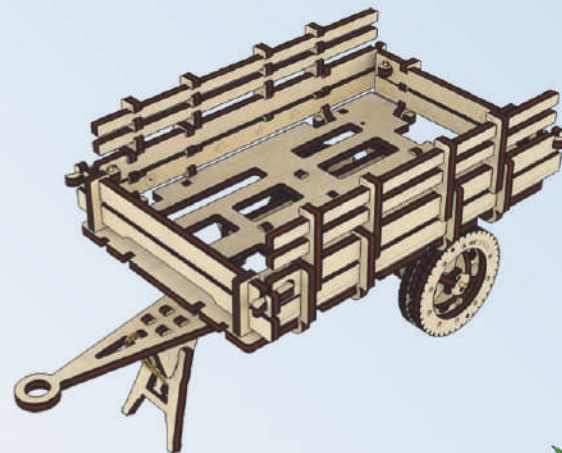

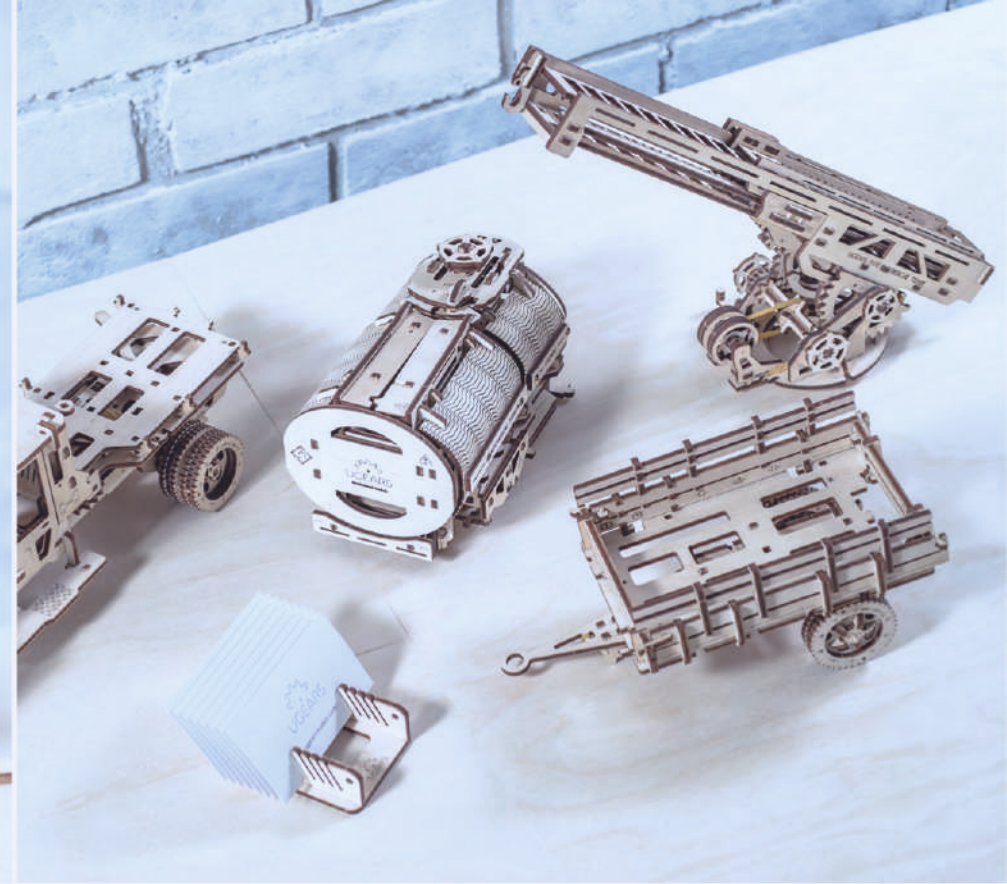

ENG Thanks for following along on this journey with us. UKR Дякуємо, що ви пройшли цей шлях з нами. DEU Vielen Dank, dass Sie diesen Weg mit uns gegangen sind.  
FRA Merci denous avoir accompagnés tout au long de ces étapes. POL Dziękujemy, że razem z nami pokonałeś tę drogę! SPA Gracias por haber recorrido el camino con nosotros. ITA Grazie per aver fatto questo percorso con noi. TUR Bizimle bu yolu geçtiğiniz için teşekkür ederiz. RUS Спасибо, что вы прошли этот путь с нами. KOR UGEARS와 함께해 주셔서 감사합니다. CHI 感谢您参与有趣的模型拼装过程。